



	pagina <i>page</i>
• Informazioni tecniche <i>Technical information</i>	372
• Filtri separatori <i>Filter-water-separators</i>	376
• Microfiltri-depuratori <i>Sub-micro-filters</i>	384
• Filtri a carbone attivo <i>Activated carbon filters</i>	386
• Regolatori di pressione <i>Pressure regulators</i>	388
• Lubrificatori <i>Lubricators</i>	400
• Filtroregolatori <i>Filter-regulators</i>	408
• Gruppi trattamento aria FR+L <i>FR+L air preparation units</i>	416
• Gruppi trattamento aria FRL <i>FRL air preparation units</i>	424
• Valvole di sezionamento circuito, di scarico rapido e avviatore progressivo <i>Shut-off valves, quick exhaust valves and slow-start valve</i>	432
• Regolatore proporzionale elettronico <i>Electronically controlled proportional pressure regulator</i>	444
• Accessori <i>Accessories</i>	452
• Novità 2005 - nuova serie gruppi trattamento aria G1" <i>New range air preparation units G1"</i>	463

NOTE GENERALI

I gruppi trattamento aria AZ Pneumatica sono il frutto di una costante attività di ricerca e analisi che ha portato a un prodotto che si adatta perfettamente alle richieste dell'utilizzatore finale. Sono disponibili regolatori e filtroregolatori con diversi livelli di pressione e grado di filtraggio; lubrificatori con bassa pressione di inserzione; valvole di sezionamento circuito e avviatori progressivi che permettono di completare il gruppo soddisfacendo le più svariate necessità applicative.

GENERAL NOTES

The FRL units AZ Pneumatica are the result of a specialized research activity aiming at user-oriented solutions. Regulators, filters and filter-regulators are available with different levels of pressure range and filter element. Lubricators guarantee low start flow rates and constant performances. Some accessories (slow-start valve and shut-off valve) can extend the choice in order to solve any kind of problem.

Grandi prestazioni

L'enorme potenziale di rendimento è il risultato di una costruzione semplice e ottimizzata: l'attenzione posta nella progettazione di particolari importanti quali la membrana e la valvola di compensazione garantisce funzionalità, stabilità e alto rendimento. La tecnologia impiegata consente una perfetta compensazione della portata garantendo un valore di isteresi ottimale con una ridottissima differenza di pressione tra lo scarico della sovrappressione (relieving) e la pressione di esercizio.

Analoghi risultati si ottengono, nella versione miniaturizzata da G1/4", con un sistema di regolazione a pistone.

High performances

Thanks to a good research, the building concept of our components (diaphragm, balanced valves, etc.) can guarantee stability, high flow rates, reliability. Very low hysteresis has been obtained with a good compensation between relieving and working pressure.

Small-sized regulators (G1/4" ports) can offer similar results with a piston based regulation system.

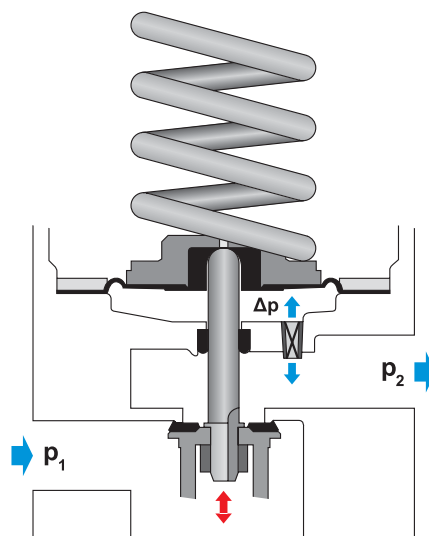

5

SISTEMA DI REGOLAZIONE A PISTONE

piston based regulation system

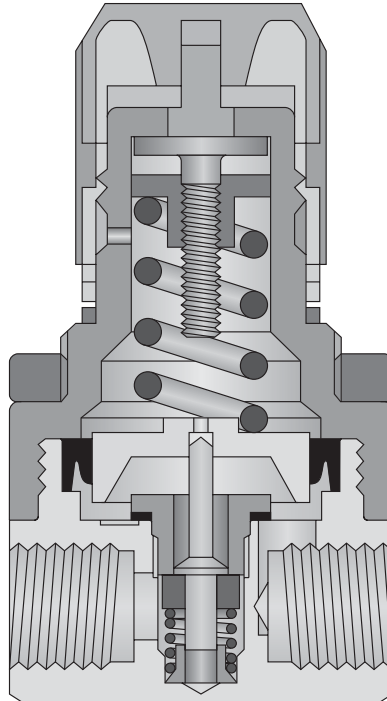

SISTEMA DI REGOLAZIONE A MEMBRANA

diaphragm based regulation system

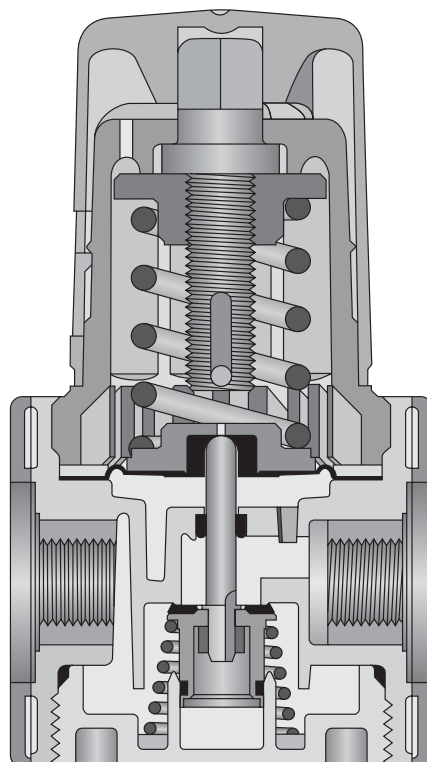

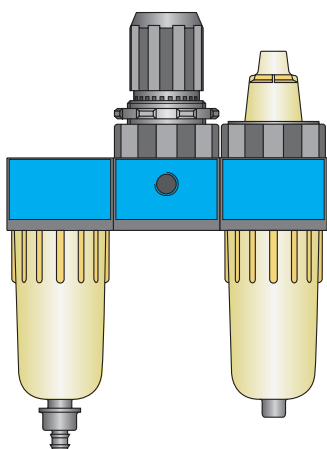

G1/4"

- Gamma miniaturizzata
- Portata: 600 NI/min
- Pressione di esercizio: 0 ... 8 bar
0 ... 0.8 MPa
- Tazza trasparente in polimero rinforzato
- Scarico semiautomatico della condensa
- Microfiltri ad elevate prestazioni
- Accessori assemblabili a richiesta

- *Very small dimensions*
- *Flow rate: 600 NI/min*
- *Working pressure: 0 ... 8 bar
0 ... 0.8 MPa*
- *Transparent bowl in reinforced polymer*
- *Semi-automatic moisture exhaust*
- *Sub-micro-filters with high performances*
- *Accessories on request*

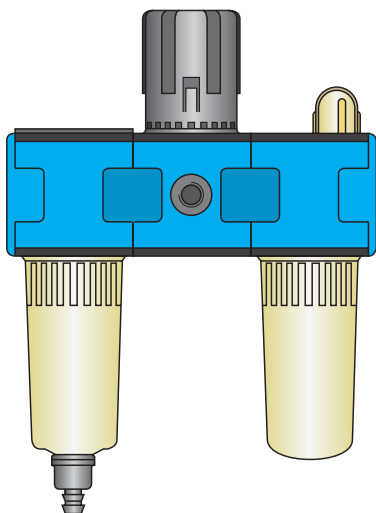

G3/8"

- Elevata modularità
- Portata: 1000 NI/min
- Pressione di esercizio: 0 ... 8 bar
0 ... 0.8 MPa
- Tazza trasparente con protezione a richiesta
- Scarico semiautomatico della condensa
(a richiesta scarico automatico)
- Microfiltri ad elevate prestazioni
- Accessori assemblabili a richiesta

- *High modularity*
- *Flow rate: 1000 NI/min*
- *Working pressure: 0 ... 8 bar
0 ... 0.8 MPa*
- *Transparent bowl with protection on request*
- *Semi-automatic moisture exhaust
(on request automatic exhaust)*
- *Sub-micro-filters with high performances*
- *Accessories on request*

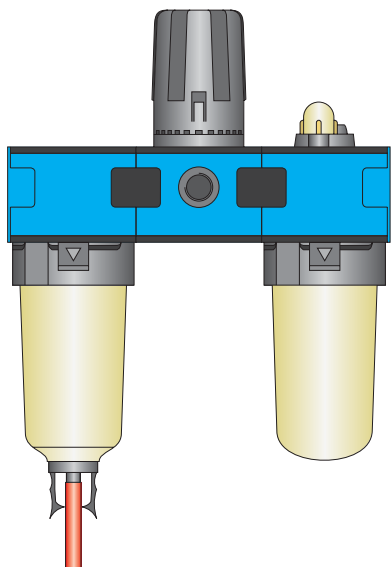

G1/2"

- Elevata modularità
- Portata: 2000 NI/min
- Pressione di esercizio: 0 ... 8 bar
0 ... 0.8 MPa
- Tazza trasparente con protezione a richiesta
- Scarico semiautomatico della condensa
(a richiesta scarico automatico)
- Microfiltri ad elevate prestazioni
- Accessori assemblabili a richiesta

- *High modularity*
- *Flow rate: 2000 NI/min*
- *Working pressure: 0 ... 8 bar
0 ... 0.8 MPa*
- *Transparent bowl with protection on request*
- *Semi-automatic moisture exhaust
(on request automatic exhaust)*
- *Sub-micro-filters with high performances*
- *Accessories on request*

5

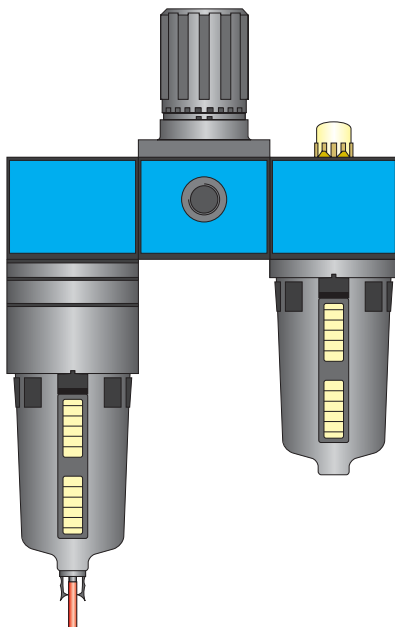

G1"

- Elevata modularità
- Portata: 5000 NI/min
- Pressione di esercizio: 0 ... 10 bar
0 ... 1 MPa
- Tazza metallica
- Scarico semiautomatico della condensa
(a richiesta scarico automatico)
- Accessori assemblabili a richiesta

- High modularity
- Flow rate: 5000 NI/min
- Working pressure: 0 ... 10 bar
0 ... 1 MPa
- Metal bowl
- Semi-automatic moisture exhaust
(on request automatic exhaust)
- Accessories on request

NUOVA SERIE A PARTIRE DAL 2005 (vedi pagine 464-476)

NEW SERIES FROM YEAR 2005 (see pages 464-476)

filtro separatore G1/4"

G1/4" filter-water-separator



- Sistema di funzionamento: gruppo ciclone ed elemento filtrante
Cyclone system and filter element
- Separazione condensa: > 90%
Moisture separation: > 90%
- Scarico semiautomatico della condensa
Semi-automatic moisture exhaust
- Capacità della tazza: 12 cm³
Bowl capacity: 12 cm³
- Protezione in plastica della tazza a richiesta (cod. PR 2-00)
Plastic bowl protection on request (code PR 2-00)
- Installazione verticale
Vertical installation



CODICE DI ORDINAZIONE <i>ORDER CODE</i>			FIL 2-25-S	FIL 2-05-S
Attacchi <i>Parts</i>			G1/4"	G1/4"
Temperatura di esercizio <i>Temperature range</i>			max +50°C	max +50°C
Peso <i>Weight</i>			0.1 kg	0.1 kg
Pressione di esercizio <i>Working pressure range</i>		p_{min} p_{max}	0 bar; 0 MPa 10 bar; 1 MPa	0 bar; 0 MPa 10 bar; 1 MPa
Portata raccomandata <i>Recommended flow rate</i>	$\rho = 6.3 \text{ bar a } 25 \text{ m/s}$ $\rho = 6.3 \text{ bar at } 25 \text{ m/s}$	Q_n	550 NI/min	550 NI/min
Elemento filtrante <i>Filter element</i>			25 μm	5 μm

Caratteristiche di portata
Flow characteristics

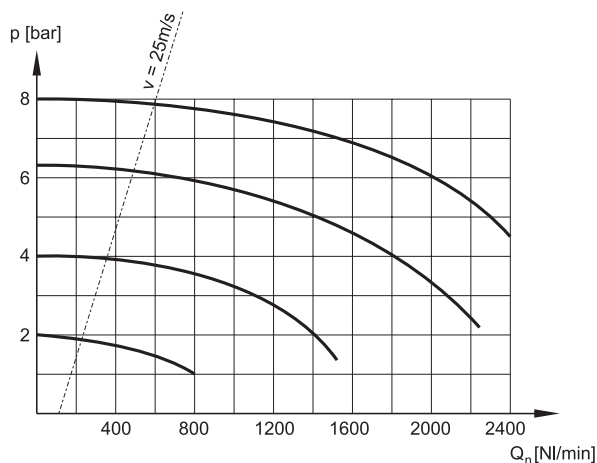

filtro separatore G1/4"

G1/4" filter-water-separator

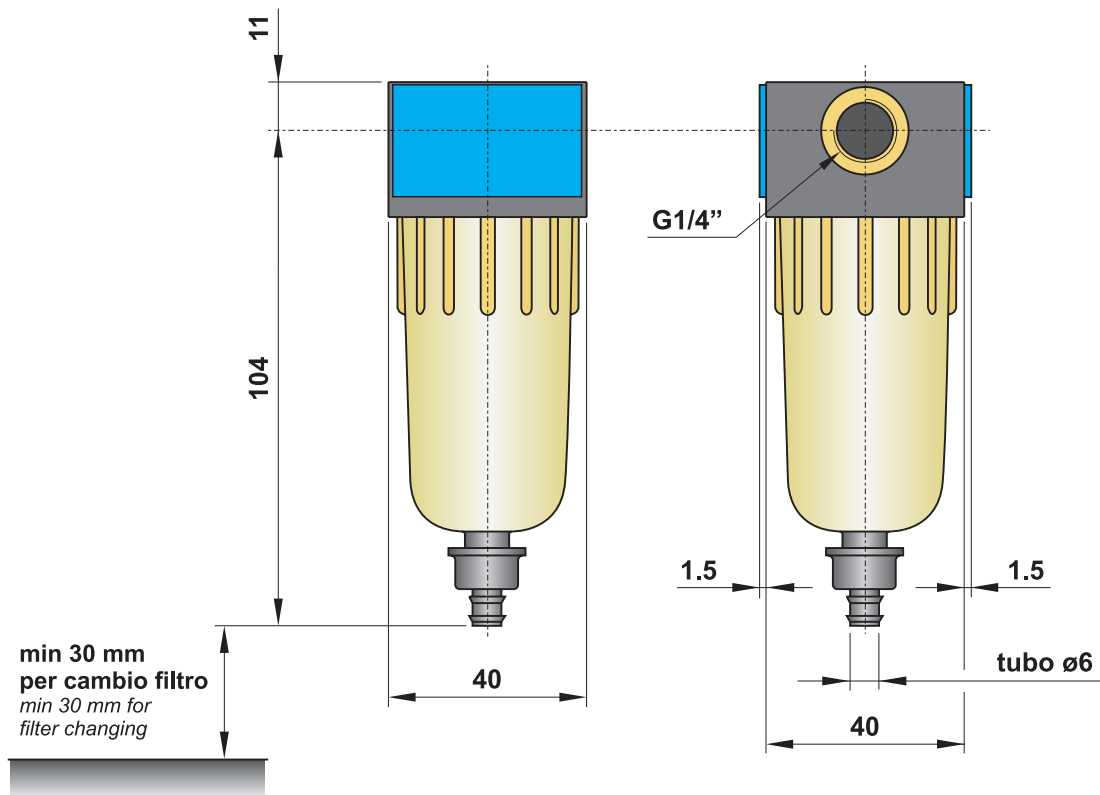
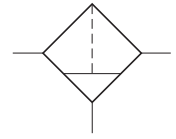

Materiali

Corpo: polimero rinforzato con inserti filettati in ottone

Guarnizioni: NBR

Parti interne: ottone, INOX e polimeri

Tazza: policarbonato rinforzato

Materials

Body: reinforced polymer with brass thread inserts

Seals: NBR

Internal parts: brass, stainless steel and polymer

Bowl: reinforced polycarbonate

filtro separatore G3/8"

G3/8" filter-water-separator



- Sistema di funzionamento: gruppo ciclone ed elemento filtrante
Cyclone system and filter element
- Separazione condensa: > 90%
Moisture separation: > 90%
- Scarico della condensa semiautomatico o automatico
Semi-automatic or automatic moisture exhaust
- Capacità della tazza: 22 cm³
Bowl capacity: 22 cm³
- Installazione verticale; staffa di fissaggio a richiesta (cod. STF 3)
Vertical installation; bracket on request (code STF 3)
- Protezione metallica della tazza a richiesta (cod. PR 3-00)
Metal bowl protection on request (code PR 3-00)



CODICE DI ORDINAZIONE <i>ORDER CODE</i>			FIL 3-30-S	FIL 3-30-A	FIL 3-05-S
Attacchi <i>Ports</i>			G3/8"	G3/8"	G3/8"
Scarico della condensa <i>Moisture exhaust</i>			semiautomatico <i>semi-automatic</i>	automatico <i>automatic</i>	semiautomatico <i>semi-automatic</i>
Temperatura di esercizio <i>Temperature range</i>			max +50°C	max +50°C	max +50°C
Peso <i>Weight</i>			0.25 kg	0.25 kg	0.25 kg
Pressione di esercizio <i>Working pressure range</i>		p_{min} p_{max}	0 bar; 0 MPa 16 bar; 1.6 MPa	0 bar; 0 MPa 16 bar; 1.6 MPa	0 bar; 0 MPa 16 bar; 1.6 MPa
Portata raccomandata <i>Recommended flow rate</i>	$p = 6 \text{ bar a } 25 \text{ m/s}$ $p = 6 \text{ bar at } 25 \text{ m/s}$	Q_n	850 NI/min	850 NI/min	850 NI/min
Portata massima <i>Maximum flow rate</i>	$p = 6.3 \text{ bar; } \Delta p = 1 \text{ bar}$	Q_{max}	1520 NI/min	1520 NI/min	1520 NI/min
Elemento filtrante <i>Filter element</i>			30 μm	30 μm	5 μm

Caratteristiche di portata
Flow characteristics

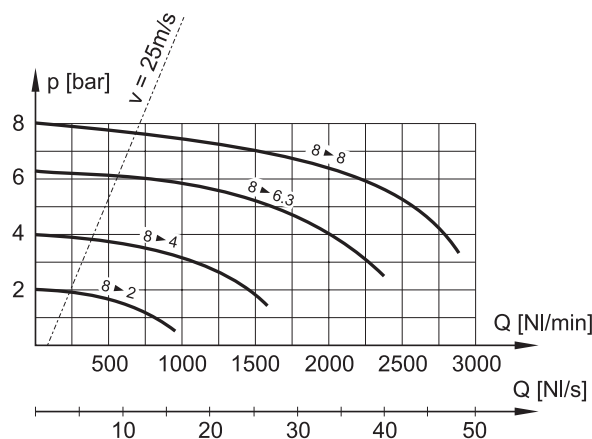

filtro separatore G3/8"

G3/8" filter-water-separator



La staffa di fissaggio deve essere acquistata separatamente.
Mounting bracket is bought separately.

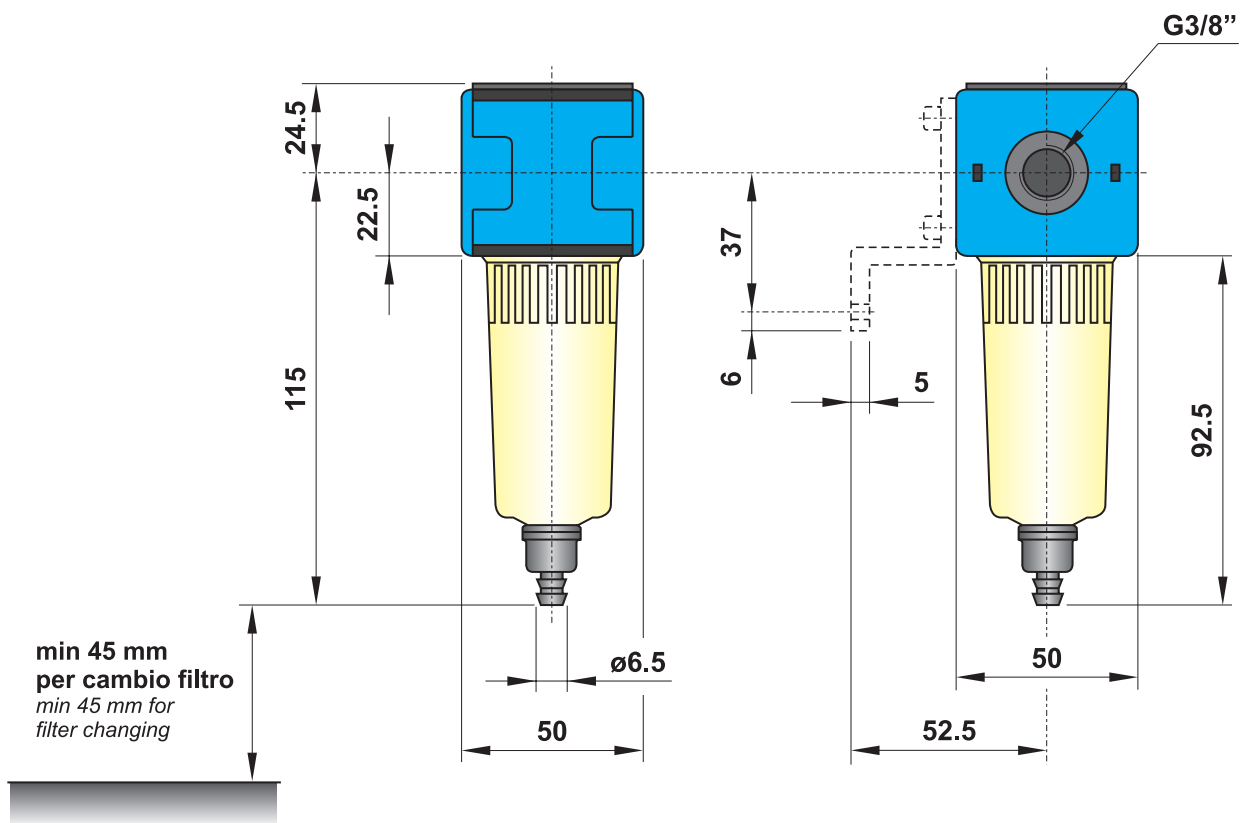
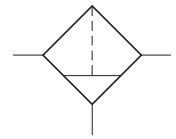

Materiali

Corpo: alluminio pressofuso

Guarnizioni: NBR

Parti interne: ottone e INOX

Parti esterne: polimeri rinforzati

Tazza: policarbonato rinforzato

Materials

Body: die-cast aluminium

Seals: NBR

Internal parts: brass and stainless steel

External parts: reinforced polymer

Bowl: reinforced polycarbonate

filtro separatore G1/2"

G1/2" filter-water-separator



- Sistema di funzionamento: gruppo ciclone ed elemento filtrante
Cyclone system and filter element
- Separazione condensa: 95%
Moisture separation: 95%
- Scarico della condensa semiautomatico o automatico
Semi-automatic or automatic moisture exhaust
- Capacità della tazza: 57 cm³
Bowl capacity: 57 cm³
- Installazione verticale; staffa di fissaggio a richiesta (cod. STF 4)
Vertical installation; bracket on request (code STF 4)
- Protezione metallica della tazza a richiesta (cod. PR 4-00)
Metal bowl protection on request (code PR 4-00)



CODICE DI ORDINAZIONE <i>ORDER CODE</i>			FIL 4-30-S	FIL 4-30-A	FIL 4-05-S
Attacchi <i>Ports</i>			G1/2"	G1/2"	G1/2"
Scarico della condensa <i>Moisture exhaust</i>			semiautomatico <i>semi-automatic</i>	automatico <i>automatic</i>	semiautomatico <i>semi-automatic</i>
Temperatura di esercizio <i>Temperature range</i>			max +50°C	max +50°C	max +50°C
Peso <i>Weight</i>			0.55 kg	0.55 kg	0.55 kg
Pressione di esercizio <i>Working pressure range</i>		p_{\min} p_{\max}	0 bar; 0 MPa 16 bar; 1.6 MPa	0 bar; 0 MPa 16 bar; 1.6 MPa	0 bar; 0 MPa 16 bar; 1.6 MPa
Portata raccomandata <i>Recommended flow rate</i>	$p = 6 \text{ bar a } 25 \text{ m/s}$ $p = 6 \text{ bar at } 25 \text{ m/s}$	Q_n	1900 NI/min	1900 NI/min	1900 NI/min
Portata massima <i>Maximum flow rate</i>	$p = 6.3 \text{ bar; } \Delta p = 1 \text{ bar}$	Q_{\max}	5000 NI/min	5000 NI/min	5000 NI/min
Elemento filtrante <i>Filter element</i>			30 μm	30 μm	5 μm

Caratteristiche di portata
Flow characteristics

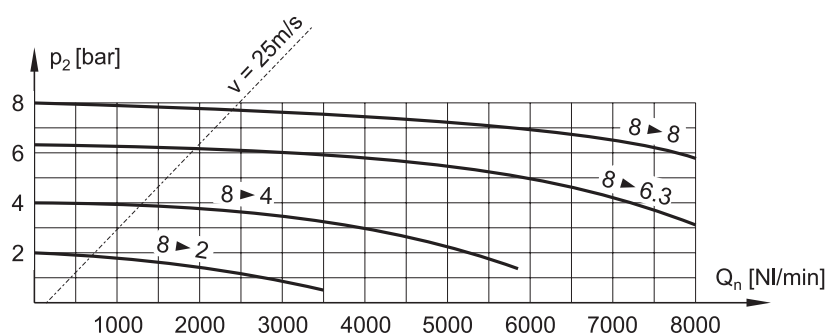

filtro separatore G1/2"

G1/2" filter-water-separator



La staffa di fissaggio deve essere acquistata separatamente.
Mounting bracket is bought separately.

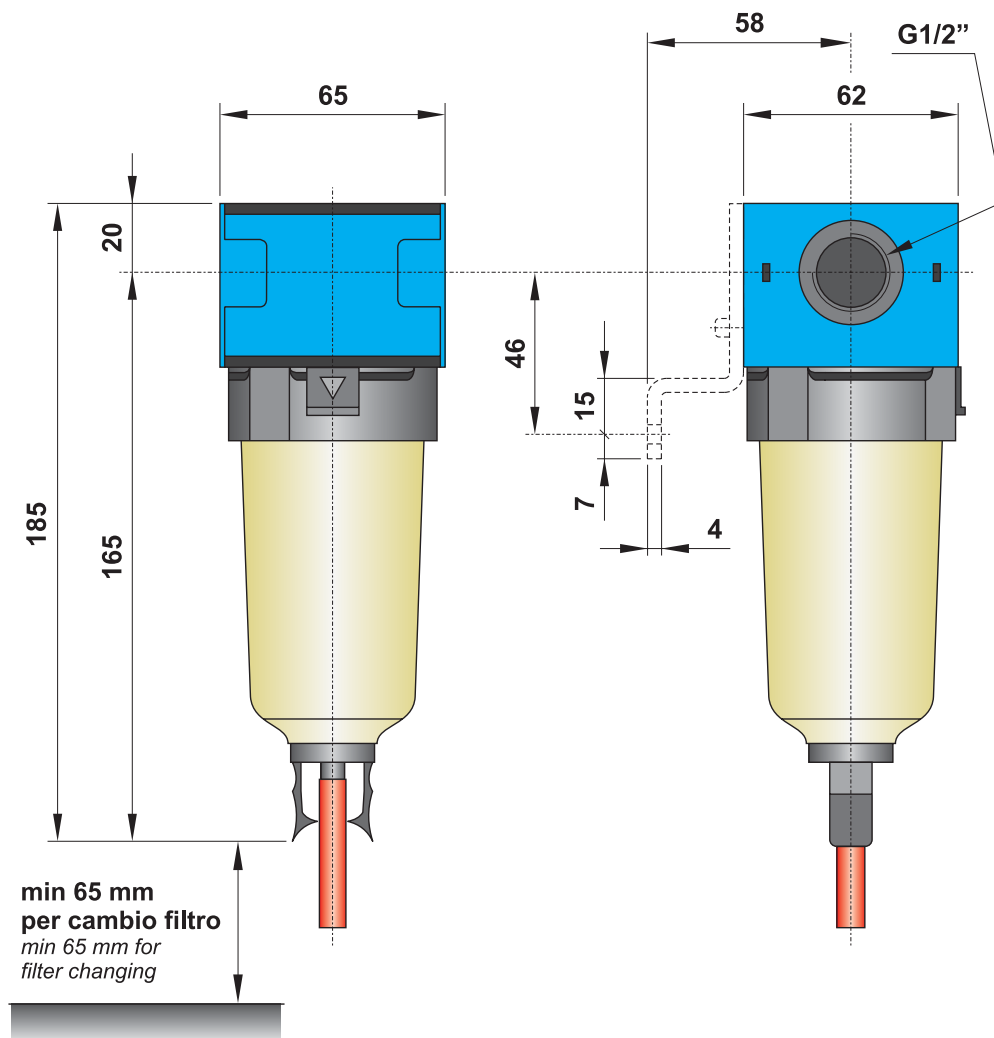
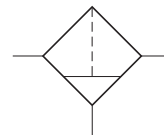

Materiali

Corpo: alluminio pressofuso

Guarnizioni: NBR

Parti interne: ottone e INOX

Parti esterne: polimeri rinforzati

Tazza: policarbonato rinforzato

Materials

Body: die-cast aluminium

Seals: NBR

Internal parts: brass and stainless steel

External parts: reinforced polymer

Bowl: reinforced polycarbonate

filtro separatore G1"

G1" filter-water-separator



- Sistema di funzionamento: gruppo ciclone ed elemento filtrante
Cyclone system and filter element
- Separazione condensa: 96%
Moisture separation: 96%
- Scarico della condensa semiautomatico o automatico
Semi-automatic or automatic moisture exhaust
- Capacità della tazza: 500 cm³
Bowl capacity: 500 cm³
- Installazione verticale; staffe di fissaggio a richiesta (cod. STF 6)
Vertical installation; brackets on request (code STF 6)
- Tazza metallica
Metal bowl



CODICE DI ORDINAZIONE <i>ORDER CODE</i>			FIL 6-30-S	FIL 6-30-A	FIL 6-05-S
Attacchi <i>Ports</i>			G1"	G1"	G1"
Scarico della condensa <i>Moisture exhaust</i>			semiautomatico <i>semi-automatic</i>	automatico <i>automatic</i>	semiautomatico <i>semi-automatic</i>
Temperatura di esercizio <i>Temperature range</i>			max +50°C	max +50°C	max +50°C
Peso <i>Weight</i>			2.2 kg	2.2 kg	2.2 kg
Pressione di esercizio <i>Working pressure range</i>		p_{\min} p_{\max}	0 bar; 0 MPa 10 bar; 1 MPa	0 bar; 0 MPa 10 bar; 1 MPa	0 bar; 0 MPa 10 bar; 1 MPa
Portata raccomandata <i>Recommended flow rate</i>	$p = 6 \text{ bar a } 25 \text{ m/s}$ $p = 6 \text{ bar at } 25 \text{ m/s}$	Q_n	5000 NI/min	5000 NI/min	5000 NI/min
Portata massima <i>Maximum flow rate</i>	$p = 6.3 \text{ bar; } \Delta p = 1 \text{ bar}$	Q_{\max}	14000 NI/min	14000 NI/min	14000 NI/min
Elemento filtrante <i>Filter element</i>			30 μm	30 μm	5 μm

Caratteristiche di portata
Flow characteristics

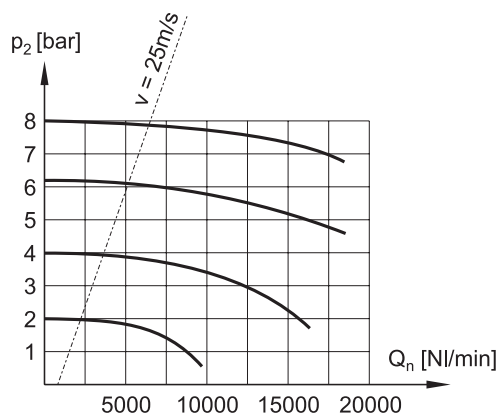

filtro separatore G1"

G1" filter-water-separator



Le staffe di fissaggio devono essere acquistate separatamente.
Mounting brackets are bought separately.

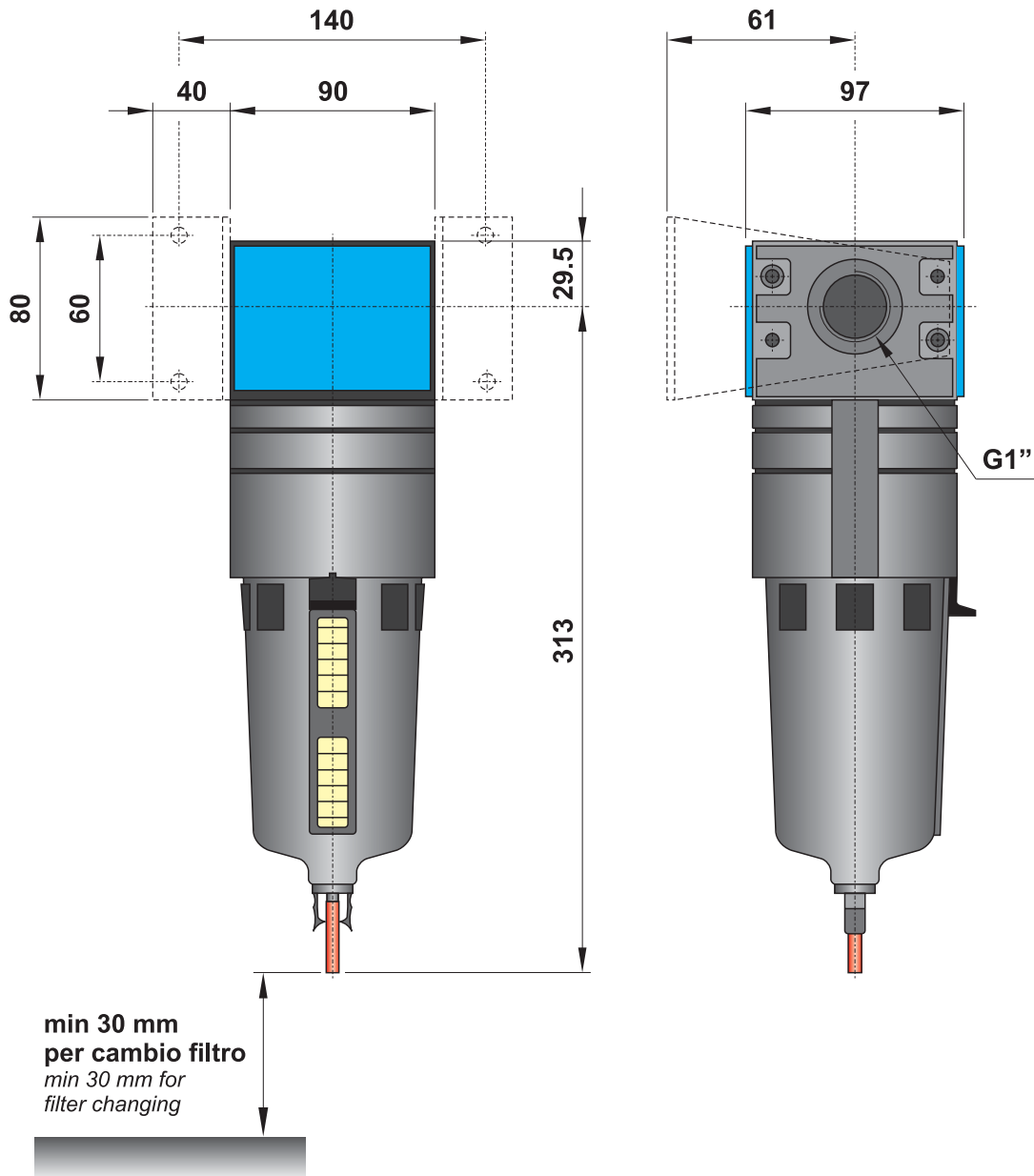
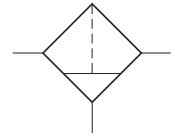

Materiali

Corpo: alluminio pressofuso

Guarnizioni: NBR

Parti interne: ottone e INOX

Parti esterne: polimeri rinforzati

Tazza: metallica

Materials

Body: die-cast aluminium

Seals: NBR

Internal parts: brass and stainless steel

External parts: reinforced polymer

Bowl: metal

microfiltri-depuratori

sub-micro-filters



- Elementi filtranti speciali ad altissime prestazioni
Special filter elements with very high performances
- Grado di filtrazione: 99.999%
Degree of filtration: 99.999%
- Olio residuo: 0.01 mg/m³ (concentrazione in entrata: 3 mg/m³)
Residual oil: 0.01 mg/m³ (input concentration: 3 mg/m³)
- Scarico manuale della condensa
Manual moisture exhaust
- Installazione verticale
Vertical installation
- Protezione metallica della tazza a richiesta
Metal bowl protection on request



Materiali

Corpo: alluminio pressofuso (per G1/4": polimero rinforzato)

Guarnizioni: NBR

Parti interne: ottone e INOX

Parti esterne: polimeri rinforzati

Tazza: policarbonato rinforzato

Materials

Body: die-cast aluminium (for G1/4": reinforced polymer)

Seals: NBR

Internal parts: brass and stainless steel

External parts: reinforced polymer

Bowl: reinforced polycarbonate

CODICE DI ORDINAZIONE <i>ORDER CODE</i>		MFIL 2-S	MFIL 3-S	MFIL 4-S
Attacchi <i>Ports</i>		G1/4"	G3/8"	G1/2"
Temperatura di esercizio <i>Temperature range</i>		max +50°C	max +50°C	max +50°C
Peso <i>Weight</i>		0.1 kg	0.3 kg	0.6 kg
Pressione di esercizio <i>Working pressure range</i>	p_{min} p_{max}	0 bar; 0 MPa 10 bar; 1 MPa	0 bar; 0 MPa 10 bar; 1 MPa	0 bar; 0 MPa 10 bar; 1 MPa
Portata raccomandata <i>Recommended flow rate</i>	Q_n	125 NI/min	200 NI/min	600 NI/min
Caduta di pressione a filtro nuovo <i>Pressure drop with new filter element</i>		0.1 bar	0.1 bar	0.1 bar
Caduta di pressione a filtro saturo <i>Pressure drop with saturated filter element</i>		0.3 bar	0.3 bar	0.3 bar

microfiltri-depuratori

sub-micro-filters



Procedura per l'installazione

Per favorire la durata degli elementi filtranti raccomandiamo di installare, in serie, un filtro-regolatore da 5 μm , un microfiltro e un filtro a carbone attivo.

Installation procedure

To increase the life span of the filter elements, we recommend the installation in the following order: filter with 5 μm degree, sub-micro-filter and activated carbon filter.

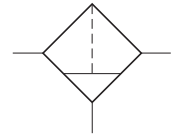
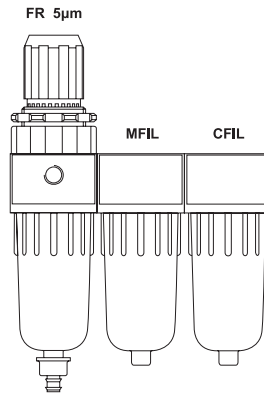

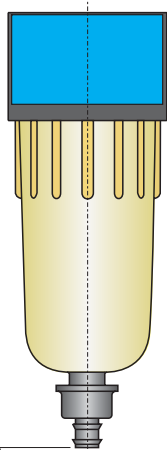
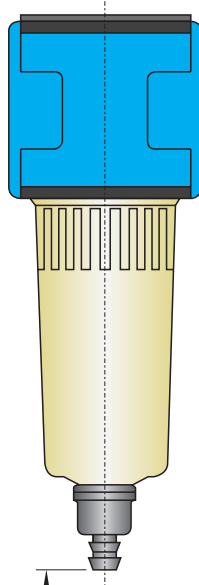
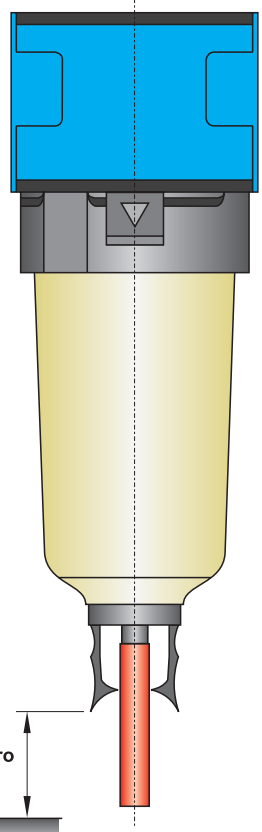
G1/4"	G3/8"	G1/2"
 <p data-bbox="119 1489 287 1579">min 50 mm per cambio filtro min 50 mm for filter changing</p>	 <p data-bbox="582 1624 750 1713">min 70 mm per cambio filtro min 70 mm for filter changing</p>	 <p data-bbox="1045 1758 1212 1848">min 120 mm per cambio filtro min 120 mm for filter changing</p>

Per le altre dimensioni si vedano le pagine dei filtri corrispondenti (G1/4": pag. 377; G3/8": pag. 379; G1/2": pag. 381).
For other dimensions refer to the corresponding filters (G1/4": page 377; G3/8": page 379; G1/2": page 381).

filtri a carbone attivo

activated carbon filters



- Elementi filtranti speciali a carbone attivo
Activated carbon filter elements
- Olio residuo: 0.003 p.p.m. in combinazione con microfiltro
Residual oil: 0.003 p.p.m. in combination with sub-micro-filter
- Scarico manuale della condensa
Manual moisture exhaust
- Installazione verticale
Vertical installation
- Protezione metallica della tazza a richiesta
Metal bowl protection on request



Materiali

Corpo: alluminio pressofuso (per G1/4": polimero rinforzato)

Guarnizioni: NBR

Parti interne: ottone e INOX

Parti esterne: polimeri rinforzati

Tazza: policarbonato rinforzato

Materials

Body: die-cast aluminium (for G1/4": reinforced polymer)

Seals: NBR

Internal parts: brass and stainless steel

External parts: reinforced polymer

Bowl: reinforced polycarbonate

CODICE DI ORDINAZIONE <i>ORDER CODE</i>		CFIL 2-S	CFIL 3-S	CFIL 4-S
Attacchi <i>Ports</i>		G1/4"	G3/8"	G1/2"
Temperatura di esercizio <i>Temperature range</i>		max +40°C	max +40°C	max +40°C
Peso <i>Weight</i>		0.1 kg	0.3 kg	0.6 kg
Pressione di esercizio <i>Working pressure range</i>	p_{min} p_{max}	0 bar; 0 MPa 10 bar; 1 MPa	0 bar; 0 MPa 10 bar; 1 MPa	0 bar; 0 MPa 10 bar; 1 MPa
Portata raccomandata <i>Recommended flow rate</i>	$p = 6 \text{ bar a } 25 \text{ m/s}$ $p = 6 \text{ bar at } 25 \text{ m/s}$	Q_n 125 NI/min	200 NI/min	600 NI/min
Caduta di pressione a filtro nuovo <i>Pressure drop with new filter element</i>		0.1 bar	0.1 bar	0.1 bar
Caduta di pressione a filtro saturo <i>Pressure drop with saturated filter element</i>		0.3 bar	0.3 bar	0.3 bar

filtri a carbone attivo

activated carbon filters



Procedura per l'installazione

Per favorire la durata degli elementi filtranti raccomandiamo di installare, in serie, un filtro-regolatore da 5 μm , un microfiltro e un filtro a carbone attivo.

Installation procedure

To increase the life span of the filter elements, we recommend the installation in the following order: filter with 5 μm degree, sub-micro-filter and activated carbon filter.

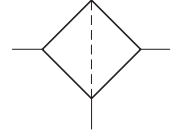
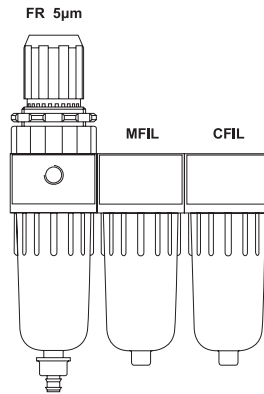

G1/4"	G3/8"	G1/2"
<p>min 50 mm per cambio filtro min 50 mm for filter changing</p>	<p>min 70 mm per cambio filtro min 70 mm for filter changing</p>	<p>min 120 mm per cambio filtro min 120 mm for filter changing</p>

Per le altre dimensioni si vedano le pagine dei filtri corrispondenti (G1/4": pag. 377; G3/8": pag. 379; G1/2": pag. 381).
For other dimensions refer to the corresponding filters (G1/4": page 377; G3/8": page 379; G1/2": page 381).

mini-regolatore di pressione

mini pressure regulator



- Regolatore a pistone con valvola di scarico sovrappressione (relieving)
Piston-type pressure regulator with relieving
- Autocompensazione durante la regolazione
Self-compensated regulation
- Corpo in alluminio 11S
Body in aluminium 11S
- Grande sensibilità
Sensitive regulation
- Installazione in linea o a pannello
In-line or panel mounting



CODICE DI ORDINAZIONE <i>ORDER CODE</i>		MREG 1-08	MREG 2-08	MREG 2-04
Attacchi <i>Ports</i>		G1/8"	G1/4"	G1/4"
Temperatura di esercizio <i>Temperature range</i>		max +50°C	max +50°C	max +50°C
Pressione di alimentazione <i>Inlet pressure range</i>	$p_{1 \text{ min}}$ $p_{1 \text{ max}}$	0 bar; 0 MPa 10 bar; 1 MPa	0 bar; 0 MPa 10 bar; 1 MPa	0 bar; 0 MPa 10 bar; 1 MPa
Pressione di utilizzo <i>Outlet pressure range</i>	$p_{2 \text{ min}}$ $p_{2 \text{ max}}$	0.5 bar; 0.05 MPa 8 bar; 0.8 MPa	0.5 bar; 0.05 MPa 8 bar; 0.8 MPa	0.5 bar; 0.05 MPa 4 bar; 0.4 MPa
Differenza minima di pressione (Δp) <i>Minimum pressure difference (Δp)</i>	$p_1 - p_2$	0.2 bar; 0.02 MPa	0.2 bar; 0.02 MPa	0.2 bar; 0.02 MPa
Isteresi <i>Hysteresis</i>	$p_1 = 10 \text{ bar} / p_2 = 0 \text{ bar}$ $p_1 = 10 \text{ bar} / p_2 = 8 \text{ bar}$	1.6 0.6	1.6 0.6	1.6 0.6
Portata raccomandata <i>Recommended flow rate</i>	$p_2 = 6.3 \text{ bar a } 25 \text{ m/s}$ $p_2 = 6.3 \text{ bar at } 25 \text{ m/s}$	Q_n	300 NI/min	550 NI/min

Caratteristiche di portata (MREG 2-08)
Flow characteristics (MREG 2-08)

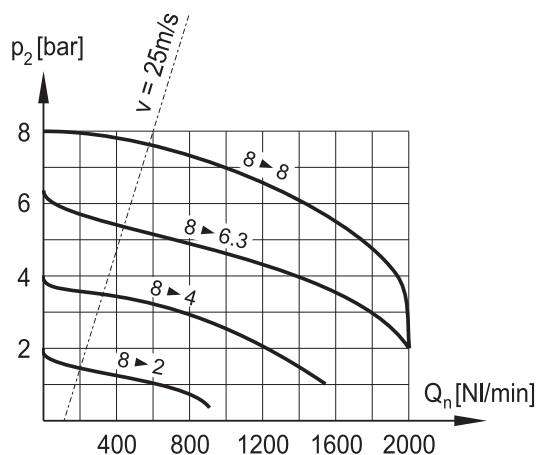

Variazione della pressione di utilizzo in presenza di fluttuazioni della pressione di alimentazione (MREG 2-08)
Outlet pressure variation with fluctuating inlet pressure (MREG 2-08)

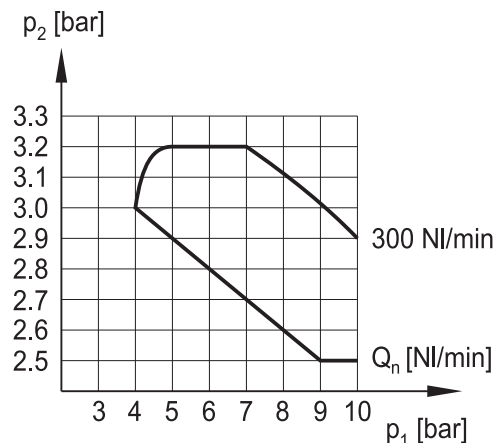

mini-regolatore di pressione

mini pressure regulator



Il manometro deve essere acquistato separatamente.
The manometer is bought separately.

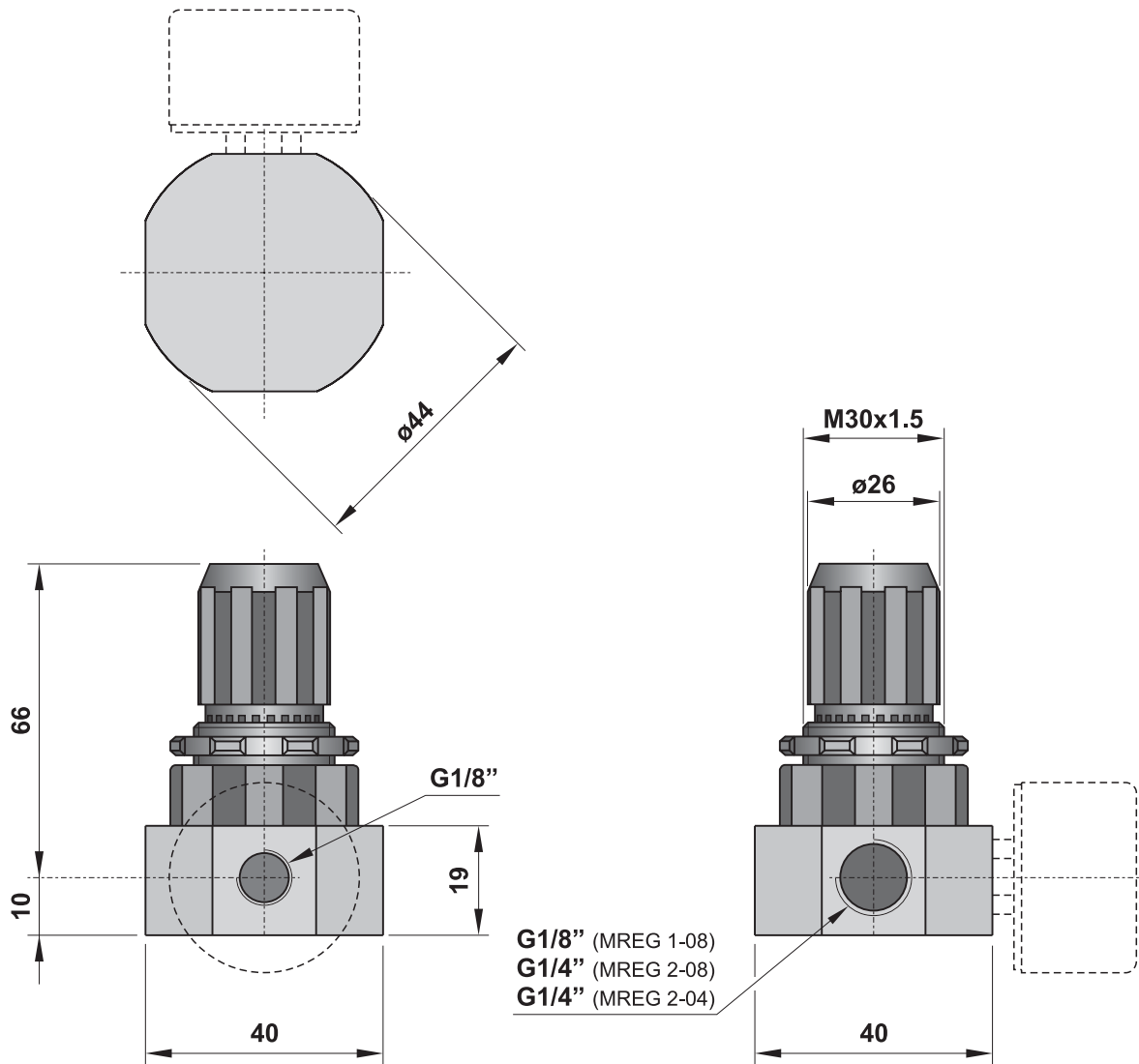
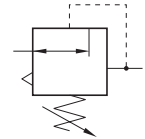

Materiali

Corpo: alluminio 11S anodizzato naturale

Molle: INOX

Guarnizioni: NBR

Parti interne: ottone, INOX e polimeri

Materials

Body: aluminium 11S (natural anodize treatment)

Springs: stainless steel

Seals: NBR

Internal parts: brass, stainless steel and polymer

regolatore di pressione G1/4"

G1/4" pressure regulator



- Regolatore a pistone con valvola di scarico sovrappressione (relieving)
Piston-type pressure regulator with relieving
- Autocompensazione durante la regolazione
Self-compensated regulation
- Alte prestazioni
High performance
- Grande sensibilità
Sensitive regulation
- Installazione in linea o a pannello; staffa di fissaggio a richiesta (cod. STF 2)
In-line or panel mounting; bracket on request (code STF 2)



CODICE DI ORDINAZIONE ORDER CODE		REG 2-08	REG 2-04
Attacchi <i>Ports</i>		G1/4"	G1/4"
Temperatura di esercizio <i>Temperature range</i>		max +50°C	max +50°C
Peso <i>Weight</i>		0.11 kg	0.11 kg
Pressione di alimentazione <i>Inlet pressure range</i>	$p_{1 \text{ min}}$ $p_{1 \text{ max}}$	0 bar; 0 MPa 10 bar; 1 MPa	0 bar; 0 MPa 10 bar; 1 MPa
Pressione di utilizzo <i>Outlet pressure range</i>	$p_{2 \text{ min}}$ $p_{2 \text{ max}}$	0.5 bar; 0.05 MPa 8 bar; 0.8 MPa	0.5 bar; 0.05 MPa 4 bar; 0.4 MPa
Differenza minima di pressione (Δp) <i>Minimum pressure difference (Δp)</i>	$p_1 - p_2$	0.2 bar; 0.02 MPa	0.2 bar; 0.02 MPa
Isteresi <i>Hysteresis</i>	$p_1 = 10 \text{ bar} / p_2 = 0 \text{ bar}$ $p_1 = 10 \text{ bar} / p_2 = 8 \text{ bar}$	1.6 0.6	1.6 0.6
Portata raccomandata <i>Recommended flow rate</i>	$p_2 = 6.3 \text{ bar a } 25 \text{ m/s}$ $p_2 = 6.3 \text{ bar at } 25 \text{ m/s}$	Q_n	Q_n
		550 NI/min	550 NI/min

Caratteristiche di portata
Flow characteristics

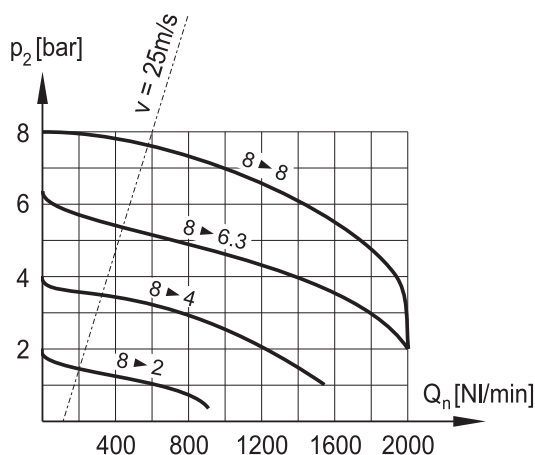

Variazione della pressione di utilizzo in presenza di fluttuazioni della pressione di alimentazione
Outlet pressure variation with fluctuating inlet pressure

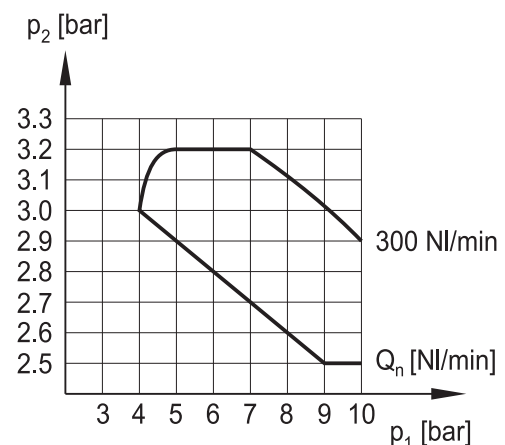

regolatore di pressione G1/4"

G1/4" pressure regulator



La staffa di fissaggio e il manometro devono essere acquistati separatamente.
Mounting bracket and manometer are bought separately.

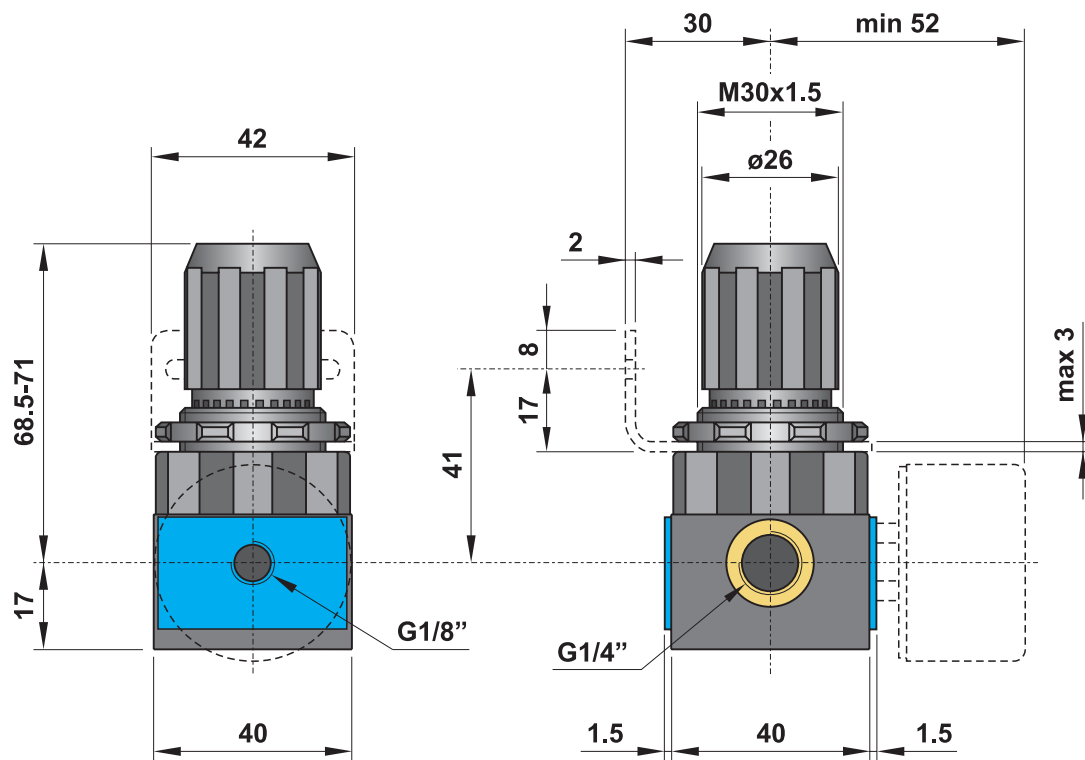
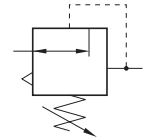

Materiali

Corpo: polimero rinforzato con inserti filettati in ottone

Molle: INOX

Guarnizioni: NBR

Parti interne: ottone, INOX e polimeri

Materials

Body: reinforced polymer with brass thread inserts

Springs: stainless steel

Seals: NBR

Internal parts: brass, stainless steel and polymer

regolatore di pressione G1/4" - SR

G1/4" pressure regulator with exhaust by-pass



- Regolatore a membrana con sistema by-pass di scarico
Diaphragm-type pressure regulator with exhaust by-pass system
- Autocompensazione durante la regolazione
Self-compensated regulation
- Elevata portata
High flow rate
- Grande sensibilità
Sensitive regulation
- Installazione in linea o a pannello; staffa di fissaggio a richiesta (cod. STF 3 o STF 3A)
In-line or panel mounting; bracket on request (code STF 3 or STF 3A)



CODICE DI ORDINAZIONE <i>ORDER CODE</i>		REG 2-08-SR	
Attacchi <i>Ports</i>		G1/4"	
Temperatura di esercizio <i>Temperature range</i>		max +60°C	
Peso <i>Weight</i>		0.3 kg	
Pressione di alimentazione <i>Inlet pressure range</i>	$p_{1 \min}$ $p_{1 \max}$	0 bar; 0 MPa 16 bar; 1.6 MPa	
Pressione di utilizzo <i>Outlet pressure range</i>	$p_{2 \min}$ $p_{2 \max}$	0.5 bar; 0.05 MPa 8 bar; 0.8 MPa	
Differenza minima di pressione (Δp) <i>Minimum pressure difference (Δp)</i>	$p_1 - p_2$	0.2 bar; 0.02 MPa	
Isteresi <i>Hysteresis</i>	$p_1 = 10 \text{ bar} / p_2 = 0 \text{ bar}$ $p_1 = 10 \text{ bar} / p_2 = 8 \text{ bar}$	0.5 0.4	
Portata raccomandata <i>Recommended flow rate</i>	$p_2 = 6 \text{ bar a } 25 \text{ m/s}$ $p_2 = 6 \text{ bar at } 25 \text{ m/s}$	Q_n	500 NI/min
Portata massima <i>Maximum flow rate</i>	$p_1 = 10 \text{ bar}; p_2 = 6.3 \text{ bar}; \Delta p = 1 \text{ bar}$	Q_{\max}	1000 NI/min

Caratteristiche di portata
Flow characteristics

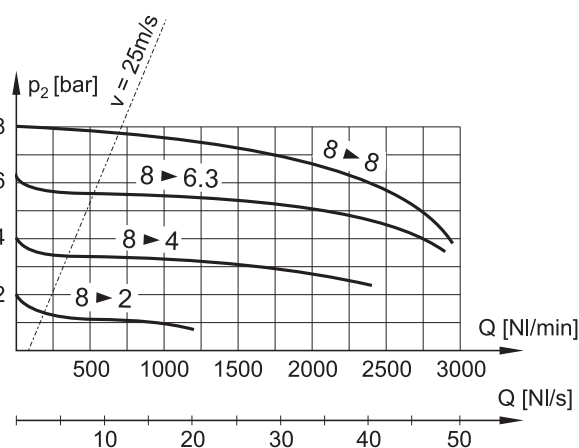

Variazione della pressione di utilizzo in presenza di fluttuazioni della pressione di alimentazione
Outlet pressure variation with fluctuating inlet pressure

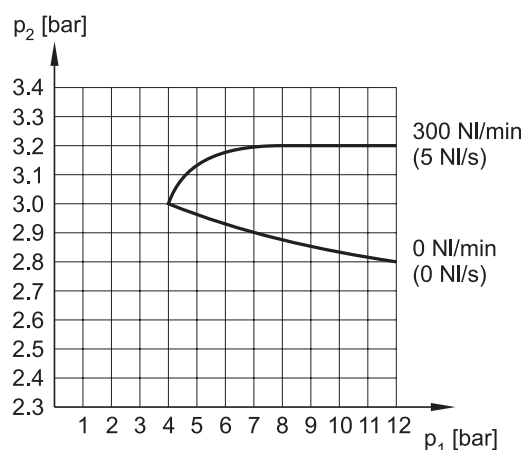

regolatore di pressione G1/4" - SR

G1/4" pressure regulator with exhaust by-pass



La staffa di fissaggio e il manometro devono essere acquistati separatamente.
Mounting bracket and manometer are bought separately.

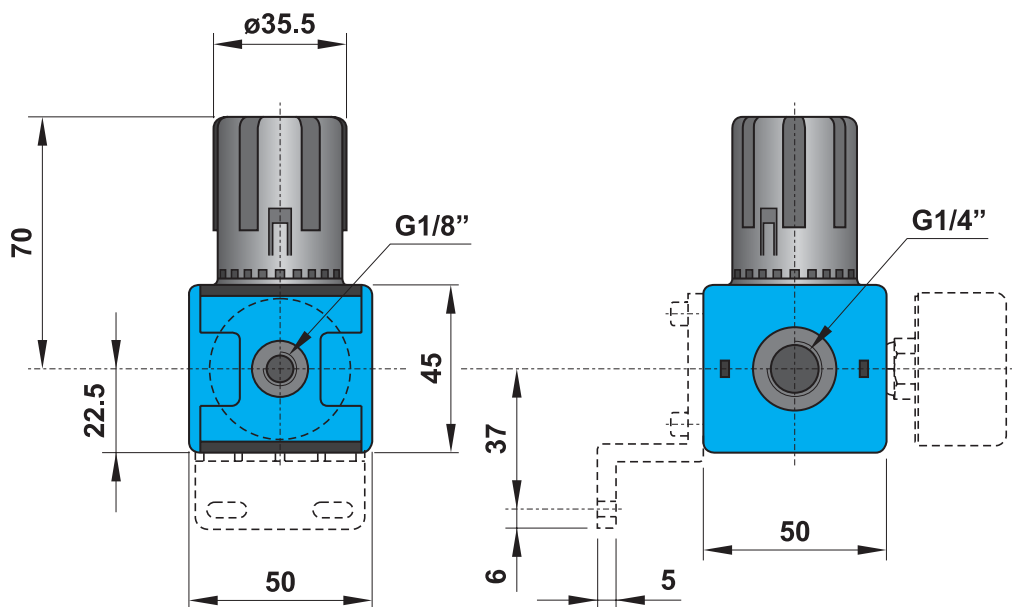
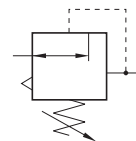

Dimensione fori per montaggio a pannello

Hole dimensions for panel mounting

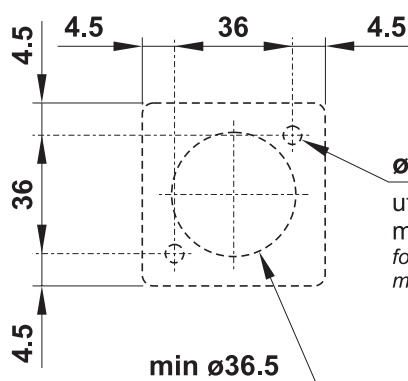

utilizzare viti autofilettanti M4 max prof. del filetto: 10 mm
for self-tapping screw M4 maximum thread depth: 10 mm

schema applicativo

application sketch

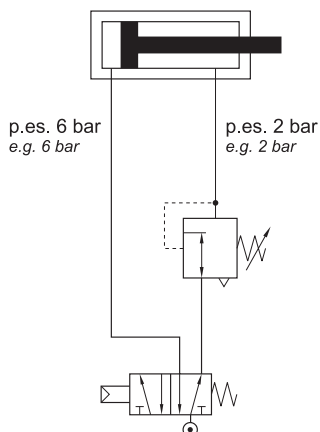

Nel circuito qui raffigurato il regolatore fa sì che l'aria in scarico proveniente dal cilindro giunga direttamente alla valvola, consentendo così un movimento alla massima pressione e velocità. L'aria necessaria alla corsa di ritorno è invece regolata a una pressione inferiore e permette un movimento più lento.

In the shown diagram, the pressure from the cylinder exhaust uses the full cross-section of the valve, allowing the cylinder to travel at full speed. In the opposite direction the air pressure is regulated at a lower level and allows a slower movement.

Materiali

Corpo: alluminio pressofuso
Molle: INOX
Guarnizioni: NBR
Parti interne: ottone e INOX
Parti esterne: polimeri rinforzati

Materials

Body: die-cast aluminium
Springs: stainless steel
Seals: NBR
Internal parts: brass and stainless steel
External parts: reinforced polymer

regolatore di pressione G3/8"

G3/8" pressure regulator



- Regolatore a membrana con valvola di scarico sovrappressione (relieving)
Diaphragm-type pressure regulator with relieving
- Autocompensazione durante la regolazione
Self-compensated regulation
- Elevata portata
High flow rate
- Grande sensibilità
Sensitive regulation
- Installazione in linea o a pannello; staffa di fissaggio a richiesta (cod. STF 3 o STF 3A)
In-line or panel mounting; bracket on request (code STF 3 or STF 3A)



CODICE DI ORDINAZIONE <i>ORDER CODE</i>		REG 3-08	
Attacchi <i>Ports</i>		G3/8"	
Temperatura di esercizio <i>Temperature range</i>		max +60°C	
Peso <i>Weight</i>		0.3 kg	
Pressione di alimentazione <i>Inlet pressure range</i>		$p_{1 \text{ min}}$ $p_{1 \text{ max}}$	0 bar; 0 MPa 16 bar; 1.6 MPa
Pressione di utilizzo <i>Outlet pressure range</i>		$p_{2 \text{ min}}$ $p_{2 \text{ max}}$	0.5 bar; 0.05 MPa 8 bar; 0.8 MPa
Differenza minima di pressione (Δp) <i>Minimum pressure difference (Δp)</i>		$p_1 - p_2$	0.2 bar; 0.02 MPa
Isteresi <i>Hysteresis</i>		$p_1 = 10 \text{ bar} / p_2 = 0 \text{ bar}$ $p_1 = 10 \text{ bar} / p_2 = 8 \text{ bar}$	0.5 0.4
Portata raccomandata <i>Recommended flow rate</i>	$p_2 = 6 \text{ bar a } 25 \text{ m/s}$ $p_2 = 6 \text{ bar at } 25 \text{ m/s}$	Q_n	850 NI/min
Portata massima <i>Maximum flow rate</i>	$p_1 = 10 \text{ bar}; p_2 = 6.3 \text{ bar}; \Delta p = 1 \text{ bar}$	Q_{max}	3300 NI/min

Caratteristiche di portata
Flow characteristics

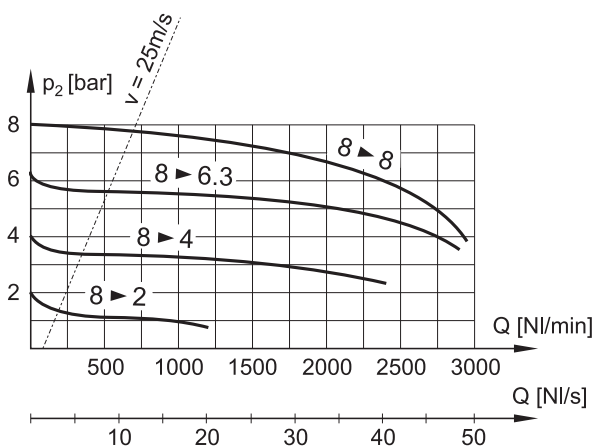

Variazione della pressione di utilizzo in presenza di fluttuazioni della pressione di alimentazione
Outlet pressure variation with fluctuating inlet pressure

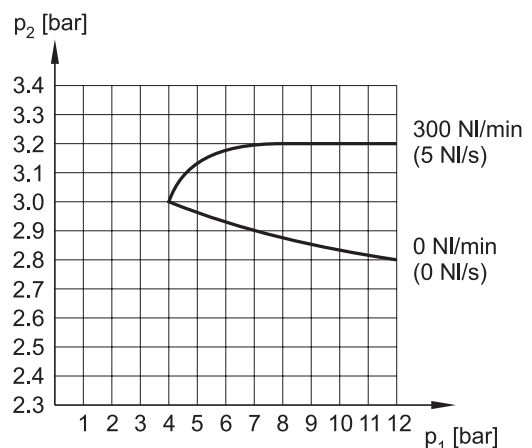

regolatore di pressione G3/8"

G3/8" pressure regulator



La staffa di fissaggio e il manometro devono essere acquistati separatamente.
Mounting bracket and manometer are bought separately.

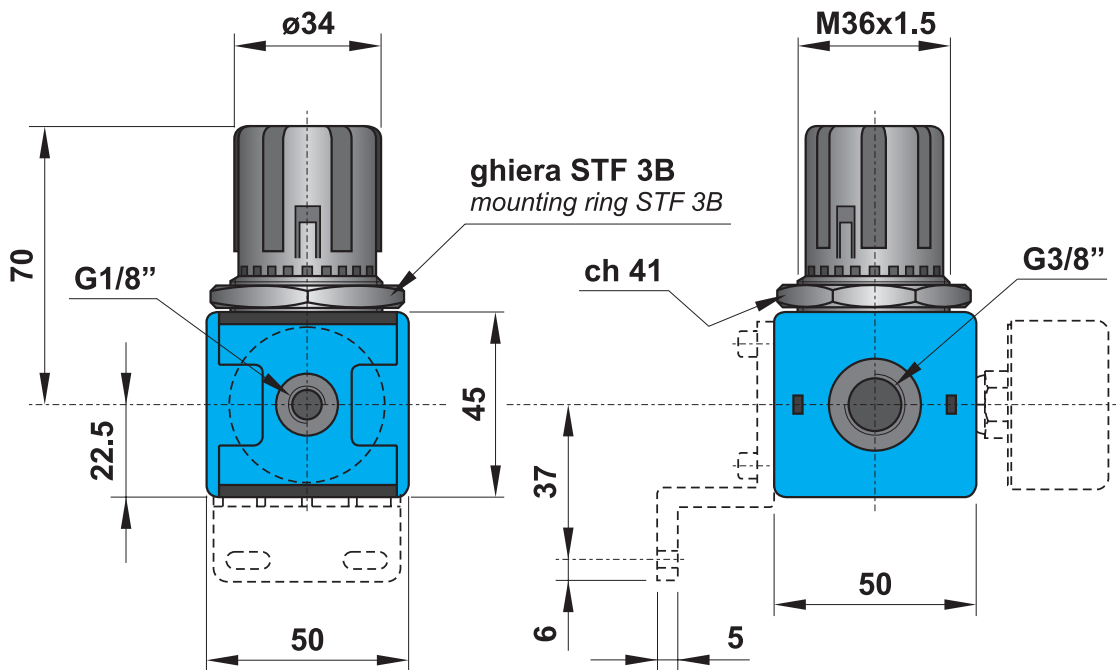
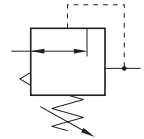

Dimensione fori per montaggio a pannello

Hole dimensions for panel mounting

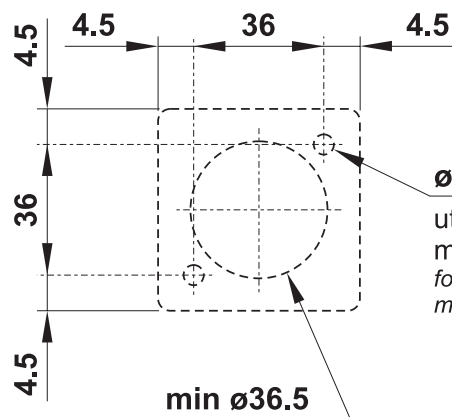

Ø4.5

utilizzare viti autofilettanti M4
max prof. del filetto: 10 mm
for self-tapping screw M4
maximum thread depth: 10 mm

Materiali

Corpo: alluminio pressofuso

Molle: INOX

Guarnizioni: NBR

Parti interne: ottone e INOX

Parti esterne: polimeri rinforzati

Materials

Body: die-cast aluminium

Springs: stainless steel

Seals: NBR

Internal parts: brass and stainless steel

External parts: reinforced polymer

regolatore di pressione G1/2"

G1/2" pressure regulator



- Regolatore a membrana con valvola di scarico sovrappressione (relieving)
Diaphragm-type pressure regulator with relieving
- Autocompensazione durante la regolazione
Self-compensated regulation
- Elevata portata
High flow rate
- Grande sensibilità
Sensitive regulation
- Installazione in linea o a pannello; staffa di fissaggio a richiesta (cod. STF 4)
In-line or panel mounting; bracket on request (code STF 4)



CODICE DI ORDINAZIONE <i>ORDER CODE</i>		REG 4-08	
Attacchi <i>Ports</i>		G1/2"	
Temperatura di esercizio <i>Temperature range</i>		max +60°C	
Peso <i>Weight</i>		0.55 kg	
Pressione di alimentazione <i>Inlet pressure range</i>	$p_{1 \text{ min}}$ $p_{1 \text{ max}}$	0 bar; 0 MPa 16 bar; 1.6 MPa	
Pressione di utilizzo <i>Outlet pressure range</i>	$p_{2 \text{ min}}$ $p_{2 \text{ max}}$	0.5 bar; 0.05 MPa 8 bar; 0.8 MPa	
Differenza minima di pressione (Δp) <i>Minimum pressure difference (Δp)</i>	$p_1 - p_2$	0.2 bar; 0.02 MPa	
Isteresi <i>Hysteresis</i>	$p_1 = 10 \text{ bar} / p_2 = 0 \text{ bar}$ $p_1 = 10 \text{ bar} / p_2 = 8 \text{ bar}$	0.9 0.7	
Portata raccomandata <i>Recommended flow rate</i>	$p_2 = 6 \text{ bar a } 25 \text{ m/s}$ $p_2 = 6 \text{ bar at } 25 \text{ m/s}$	Q_n	1900 NI/min
Portata massima <i>Maximum flow rate</i>	$p_1 = 10 \text{ bar}; p_2 = 6.3 \text{ bar}; \Delta p = 1 \text{ bar}$	Q_{max}	5700 NI/min

Caratteristiche di portata
Flow characteristics

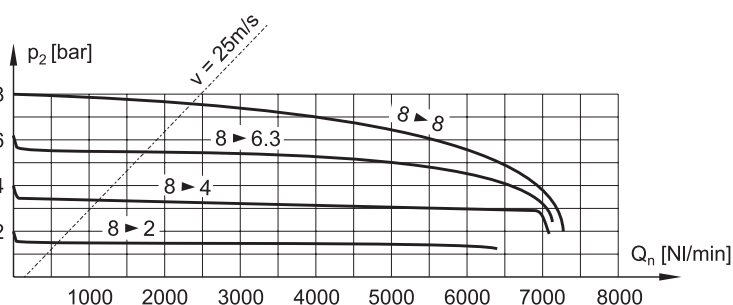

Variazione della pressione di utilizzo in presenza di fluttuazioni della pressione di alimentazione
Outlet pressure variation with fluctuating inlet pressure

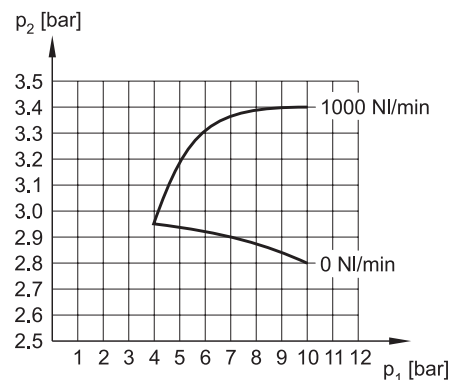

regolatore di pressione G1/2"

G1/2" pressure regulator



La staffa di fissaggio e il manometro devono essere acquistati separatamente.
Mounting bracket and manometer are bought separately.

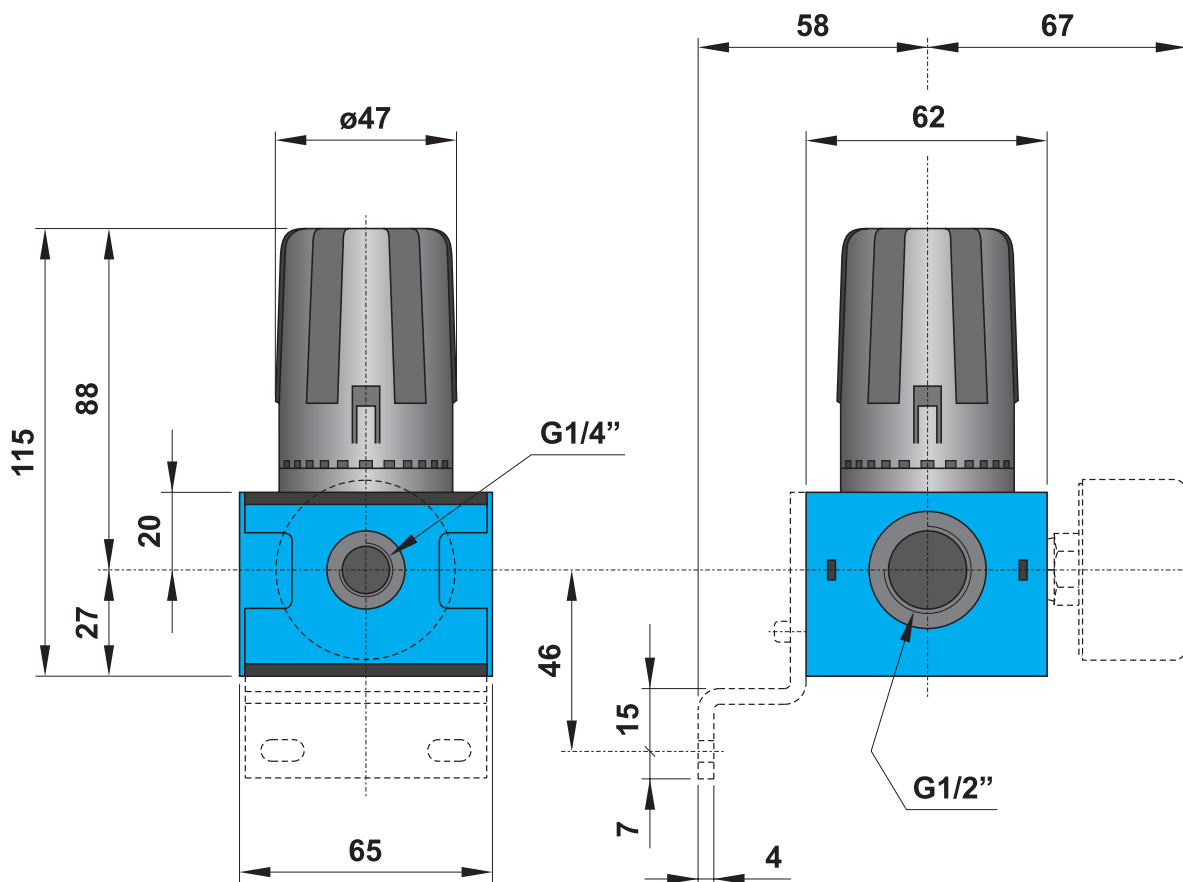
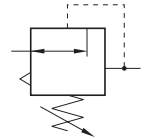

Materiali

Corpo: alluminio pressofuso

Molle: INOX

Guarnizioni: NBR

Parti interne: ottone e INOX

Parti esterne: polimeri rinforzati

Materials

Body: die-cast aluminium

Springs: stainless steel

Seals: NBR

Internal parts: brass and stainless steel

External parts: reinforced polymer

regolatore di pressione G1"

G1" pressure regulator



- Regolatore a membrana con valvola di scarico sovrappressione (relieving)
Diaphragm-type pressure regulator with relieving
- Autocompensazione durante la regolazione
Self-compensated regulation
- Elevata portata
High flow rate
- Grande sensibilità
Sensitive regulation
- Installazione in linea o a pannello; staffe di fissaggio a richiesta (cod. STF 6)
In-line or panel mounting; brackets on request (code STF 6)



CODICE DI ORDINAZIONE <i>ORDER CODE</i>		REG 6-10	
Attacchi <i>Ports</i>		G1"	
Temperatura di esercizio <i>Temperature range</i>		max +60°C	
Peso <i>Weight</i>		1.8 kg	
Pressione di alimentazione <i>Inlet pressure range</i>	$p_{1 \min}$ $p_{1 \max}$	0 bar; 0 MPa 16 bar; 1.6 MPa	
Pressione di utilizzo <i>Outlet pressure range</i>	$p_{2 \min}$ $p_{2 \max}$	0.5 bar; 0.05 MPa 10 bar; 1 MPa	
Differenza minima di pressione (Δp) <i>Minimum pressure difference (Δp)</i>	$p_1 - p_2$	0.2 bar; 0.02 MPa	
Isteresi <i>Hysteresis</i>	$p_1 = 10 \text{ bar} / p_2 = 0 \text{ bar}$ $p_1 = 10 \text{ bar} / p_2 = 8 \text{ bar}$	0.6 0.2	
Portata raccomandata <i>Recommended flow rate</i>	$p_2 = 6 \text{ bar a } 25 \text{ m/s}$ $p_2 = 6 \text{ bar at } 25 \text{ m/s}$	Q_n	5000 NI/min
Portata massima <i>Maximum flow rate</i>	$p_1 = 10 \text{ bar}; p_2 = 6.3 \text{ bar}; \Delta p = 1 \text{ bar}$	Q_{\max}	13500 NI/min

Caratteristiche di portata
Flow characteristics

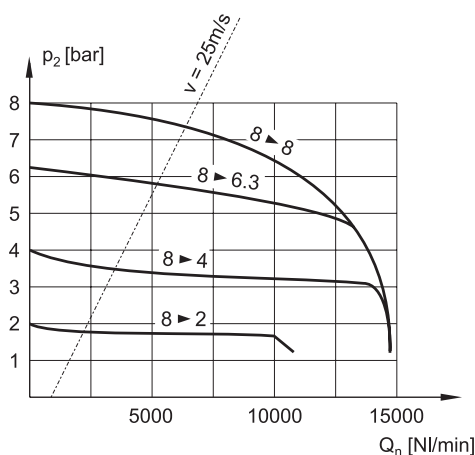

Variazione della pressione di utilizzo in presenza di fluttuazioni della pressione di alimentazione
Outlet pressure variation with fluctuating inlet pressure

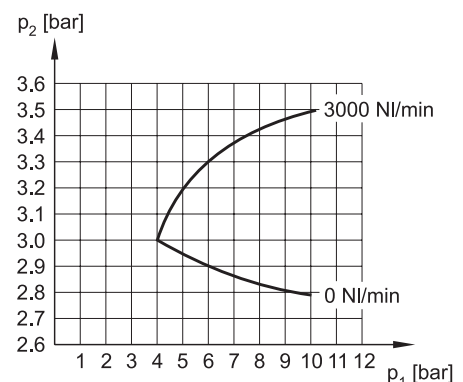

regolatore di pressione G1"

G1" pressure regulator



Le staffe di fissaggio e il manometro devono essere acquistati separatamente.
Mounting brackets and manometer are bought separately.

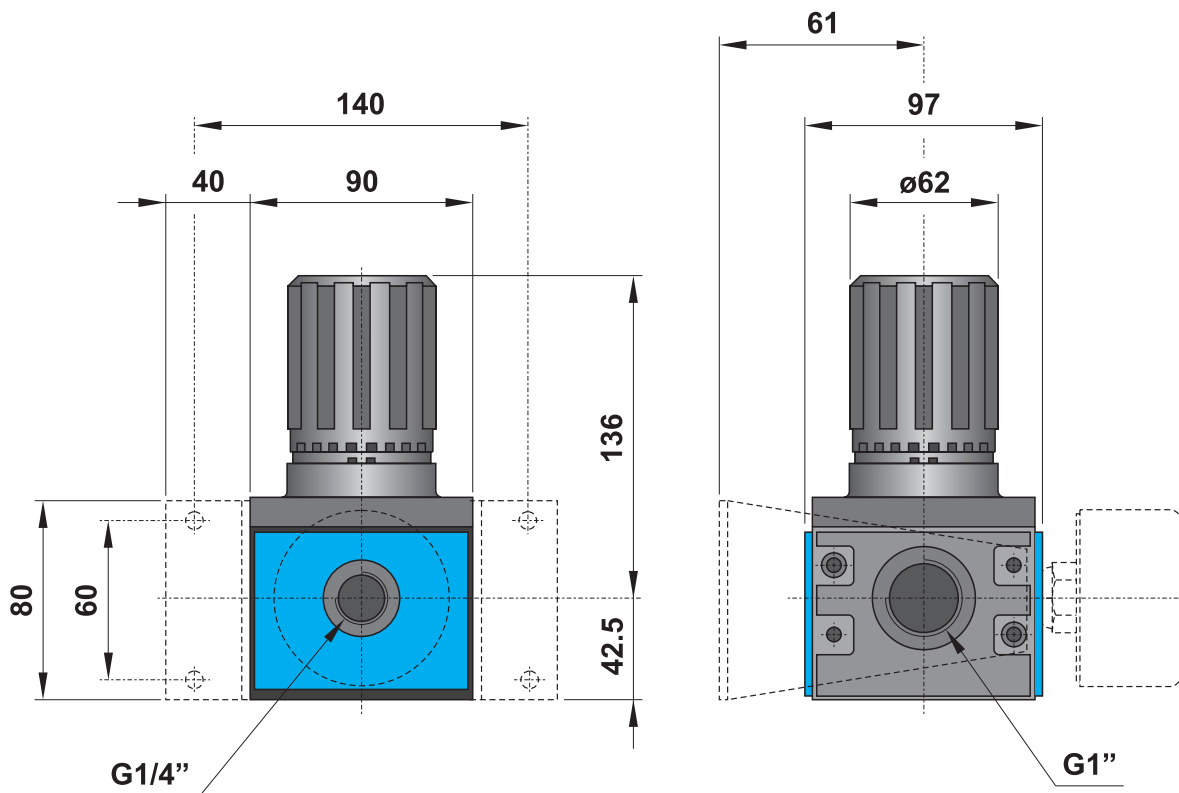
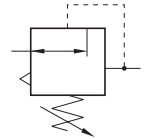

Materiali

Corpo: alluminio pressofuso

Molle: INOX

Guarnizioni: NBR

Parti interne: ottone e INOX

Parti esterne: polimeri rinforzati

Materials

Body: die-cast aluminium

Springs: stainless steel

Seals: NBR

Internal parts: brass and stainless steel

External parts: reinforced polymer

lubrificatore G1/4"

G1/4" lubricator



- Lubrificatore venturi con compensazione automatica della portata
Oil mist lubricator with flow compensation
- Il numero di gocce al minuto è costante
Number of drops per minute is constant
- Bassa portata di inserzione
Low start flow rate
- Capacità tazza: 35 cm³
Bowl capacity: 35 cm³
- Rifornimento olio manuale
Manual oil refilling
- Protezione in plastica della tazza a richiesta (cod. PR 2-00)
Plastic bowl protection on request (code PR 2-00)
- Installazione verticale
Vertical installation



CODICE DI ORDINAZIONE <i>ORDER CODE</i>		LUB 2-00	
Attacchi <i>Ports</i>		G1/4"	
Temperatura di esercizio <i>Temperature range</i>		max +50°C	
Peso <i>Weight</i>		0.09 kg	
Pressione di esercizio <i>Working pressure range</i>		P_{min}	0 bar; 0 MPa
		P_{max}	10 bar; 1 MPa
Portata raccomandata <i>Recommended flow rate</i>	$p = 6.3 \text{ bar a } 25 \text{ m/s}$ $p = 6.3 \text{ bar at } 25 \text{ m/s}$	Q_n	550 NI/min

Caratteristiche di portata
Flow characteristics

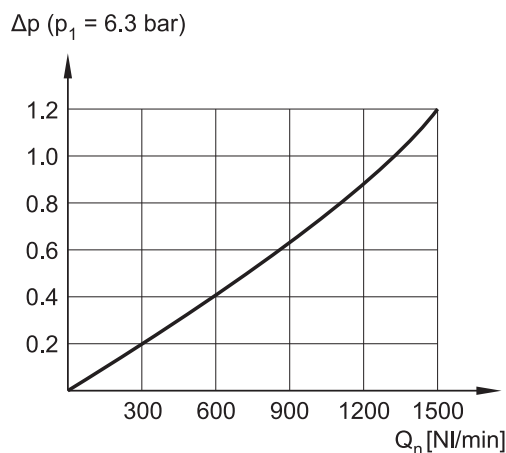

Rapporto olio/aria
Oil/air ratio

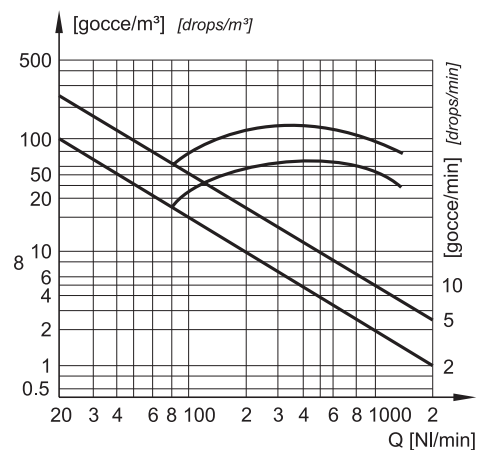

lubrificatore G1/4"

G1/4" lubricator

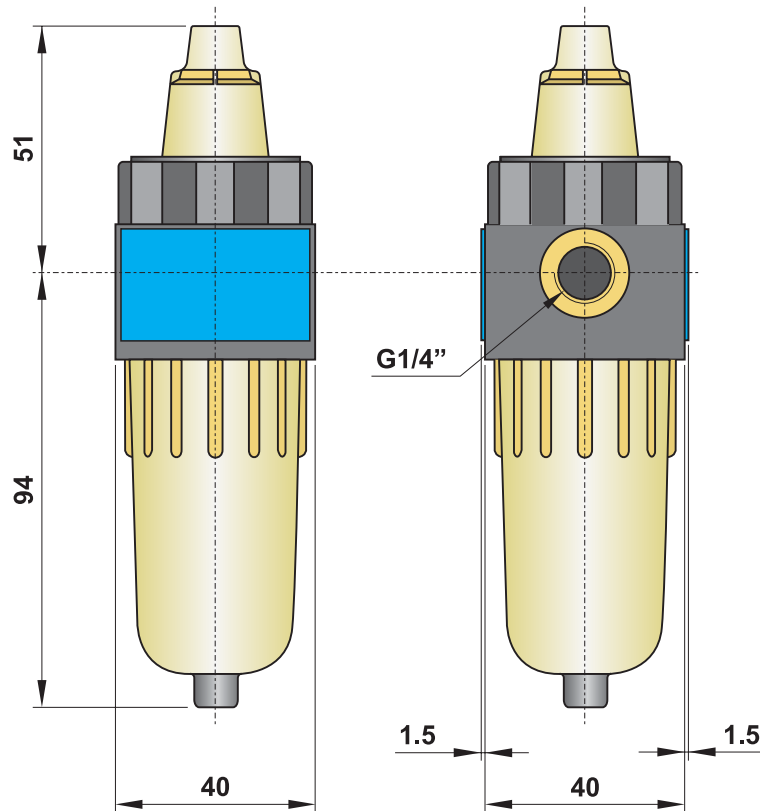
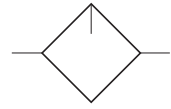

Condizioni minime di operatività
Minimum operating conditions

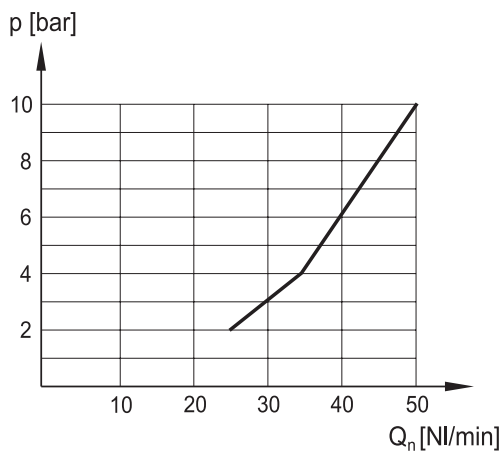

Materiali

Corpo: polimero rinforzato con inserti filettati in ottone

Molle: INOX

Guarnizioni: NBR

Parti interne: ottone, INOX e polimeri

Tazza: policarbonato rinforzato

Materials

Body: reinforced polymer with brass thread inserts

Springs: stainless steel

Seals: NBR

Internal parts: brass, stainless steel and polymer

Bowl: reinforced polycarbonate

Lubrificatore G3/8"

G3/8" lubricator



- Lubrificatore venturi con compensazione automatica della portata
Oil mist lubricator with flow compensation
- Il numero di gocce al minuto è costante
Number of drops per minute is constant
- Capacità tazza: 45 cm³
Bowl capacity: 45 cm³
- Rifornimento olio manuale
Manual oil refilling
- Installazione verticale; staffa di fissaggio a richiesta (cod. STF 3)
Vertical installation; bracket on request (code STF 3)
- Protezione metallica della tazza a richiesta (cod. PR 3-00)
Metal bowl protection on request (code PR 3-00)



CODICE DI ORDINAZIONE ORDER CODE		LUB 3-00	
Attacchi <i>Ports</i>		G3/8"	
Temperatura di esercizio <i>Temperature range</i>		max +60°C	
Peso <i>Weight</i>		0.25 kg	
Pressione di esercizio <i>Working pressure range</i>		p_{min} p_{max}	0 bar; 0 MPa 16 bar; 1.6 MPa
Portata raccomandata <i>Recommended flow rate</i>	$p = 6 \text{ bar a } 25 \text{ m/s}$ $p = 6 \text{ bar at } 25 \text{ m/s}$	Q_n	850 NI/min
Portata massima <i>Maximum flow rate</i>	$p = 6.3 \text{ bar; } \Delta p = 1 \text{ bar}$	Q_{max}	1880 NI/min

Caratteristiche di portata
Flow characteristics

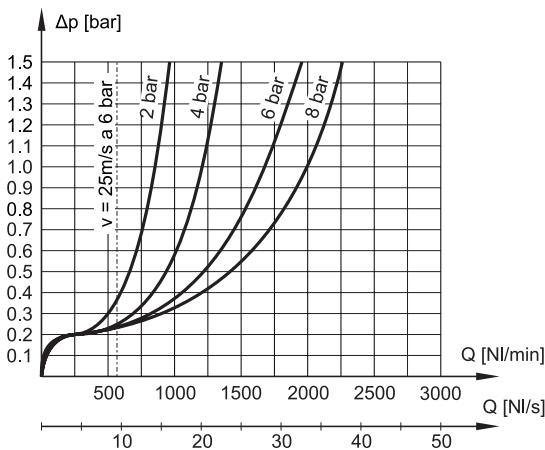

Rapporto olio/aria
Oil/air ratio

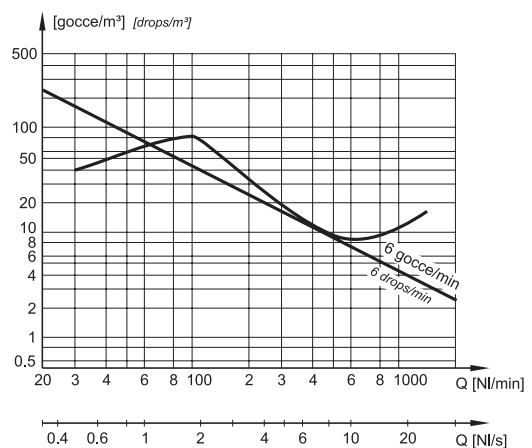

lubrificatore G3/8"

G3/8" lubricator



La staffa di fissaggio deve essere acquistata separatamente.
 Mounting bracket is bought separately.

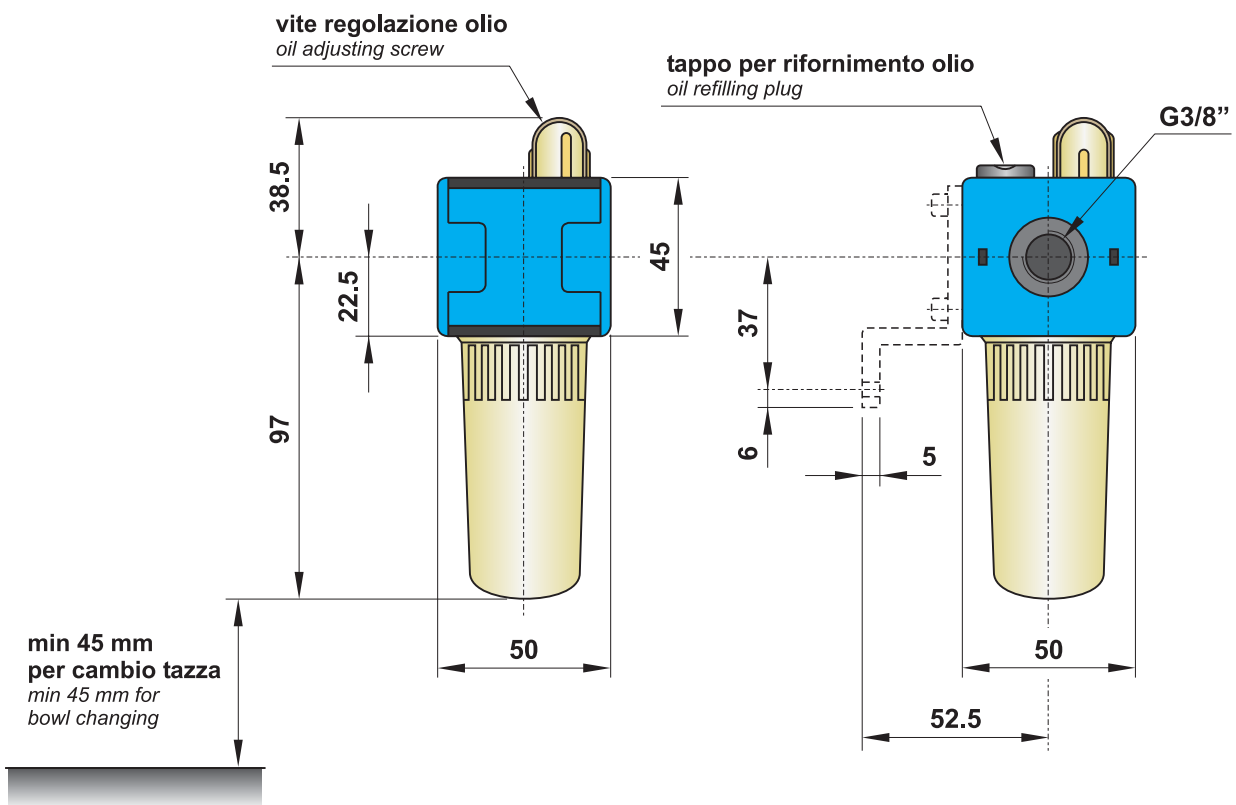
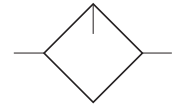

Condizioni minime di operatività
 Minimum operating conditions

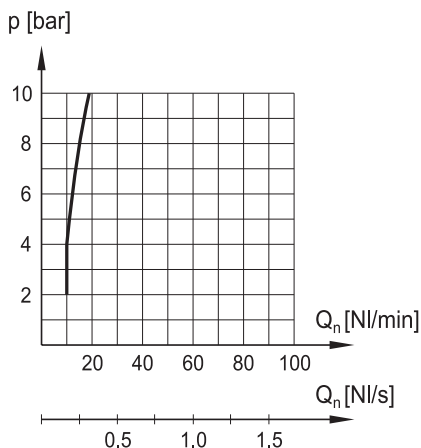

Materiali

Corpo: alluminio pressofuso

Guarnizioni: NBR

Parti interne: ottone e INOX

Parti esterne: polimeri rinforzati

Tazza: policarbonato rinforzato

Materials

Body: die-cast aluminium

Seals: NBR

Internal parts: brass and stainless steel

External parts: reinforced polymer

Bowl: reinforced polycarbonate

Lubrificatore G1/2"

G1/2" lubricator



- Lubrificatore venturi con compensazione automatica della portata
Oil mist lubricator with flow compensation
- Il numero di gocce al minuto è costante
Number of drops per minute is constant
- Capacità tazza: 112 cm³
Bowl capacity: 112 cm³
- Rifornimento olio manuale
Manual oil refilling
- Installazione verticale; staffa di fissaggio a richiesta (cod. STF 4)
Vertical installation; bracket on request (code STF 4)
- Protezione metallica della tazza a richiesta (cod. PR 4-00)
Metal bowl protection on request (code PR 4-00)



CODICE DI ORDINAZIONE ORDER CODE		LUB 4-00	
Attacchi <i>Ports</i>		G1/2"	
Temperatura di esercizio <i>Temperature range</i>		max +60°C	
Peso <i>Weight</i>		0.55 kg	
Pressione di esercizio <i>Working pressure range</i>		p_{min}	0 bar; 0 MPa
		p_{max}	16 bar; 1.6 MPa
Portata raccomandata <i>Recommended flow rate</i>	$p = 6 \text{ bar a } 25 \text{ m/s}$ $p = 6 \text{ bar at } 25 \text{ m/s}$	Q_n	1900 NI/min
Portata massima <i>Maximum flow rate</i>	$p = 6.3 \text{ bar; } \Delta p = 1 \text{ bar}$	Q_{max}	5300 NI/min

Caratteristiche di portata
Flow characteristics

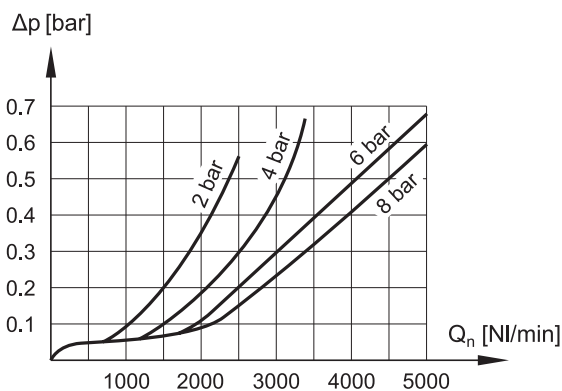

Rapporto olio/aria
Oil/air ratio

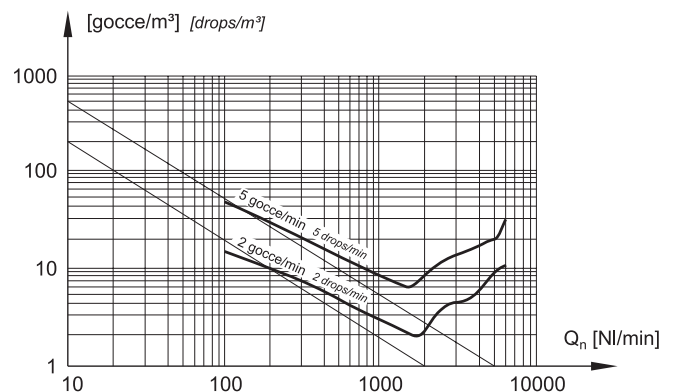

lubrificatore G1/2"

G1/2" lubricator



La staffa di fissaggio deve essere acquistata separatamente.
Mounting bracket is bought separately.

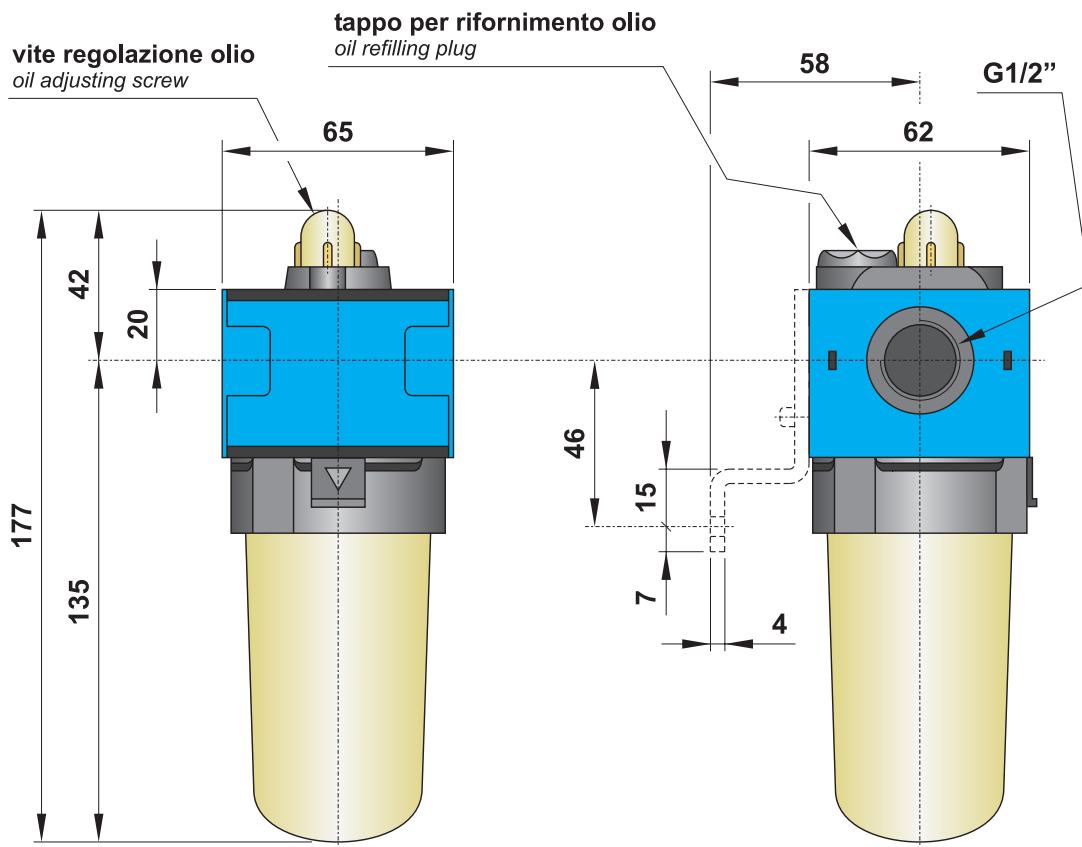
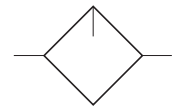

Condizioni minime di operatività
Minimum operating conditions

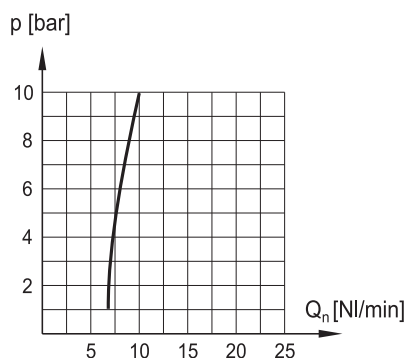

Materiali

Corpo: alluminio pressofuso

Guarnizioni: NBR

Parti interne: ottone e INOX

Parti esterne: polimeri rinforzati

Tazza: policarbonato rinforzato

Materials

Body: die-cast aluminium

Seals: NBR

Internal parts: brass and stainless steel

External parts: reinforced polymer

Bowl: reinforced polycarbonate

Lubrificatore G1"

G1" lubricator



- Lubrificatore venturi con compensazione automatica della portata
Oil mist lubricator with flow compensation
- Il numero di gocce al minuto è costante
Number of drops per minute is constant
- Capacità tazza: 500 cm³
Bowl capacity: 500 cm³
- Rifornimento olio manuale
Manual oil refilling
- Installazione verticale; staffe di fissaggio a richiesta (cod. STF 6)
Vertical installation; brackets on request (code STF 6)
- Tazza metallica
Metal bowl



CODICE DI ORDINAZIONE <i>ORDER CODE</i>		LUB 6-00	
Attacchi <i>Ports</i>		G1"	
Temperatura di esercizio <i>Temperature range</i>		max +60°C	
Peso <i>Weight</i>		1.6 kg	
Pressione di esercizio <i>Working pressure range</i>		p_{min} p_{max}	0 bar; 0 MPa 10 bar; 1 MPa
Portata raccomandata <i>Recommended flow rate</i>	$p = 6 \text{ bar a } 25 \text{ m/s}$ $p = 6 \text{ bar at } 25 \text{ m/s}$	Q_n	5000 NI/min
Portata massima <i>Maximum flow rate</i>	$p = 6.3 \text{ bar; } \Delta p = 1 \text{ bar}$	Q_{max}	18000 NI/min

Caratteristiche di portata
Flow characteristics

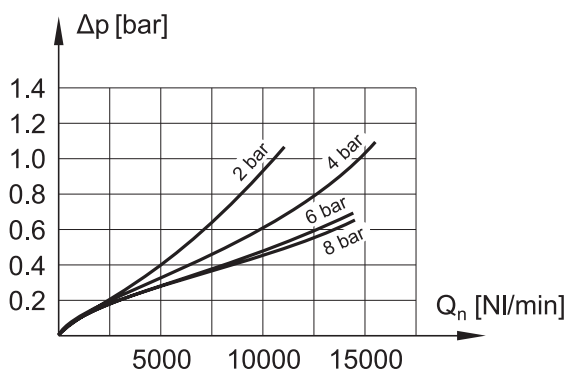

Rapporto olio/aria
Oil/air ratio

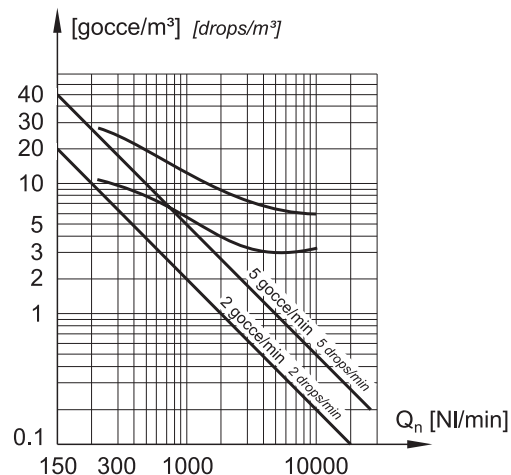

Ibrificatore G1"

G1" lubricator



Le staffe di fissaggio devono essere acquistate separatamente.
Mounting brackets are bought separately.

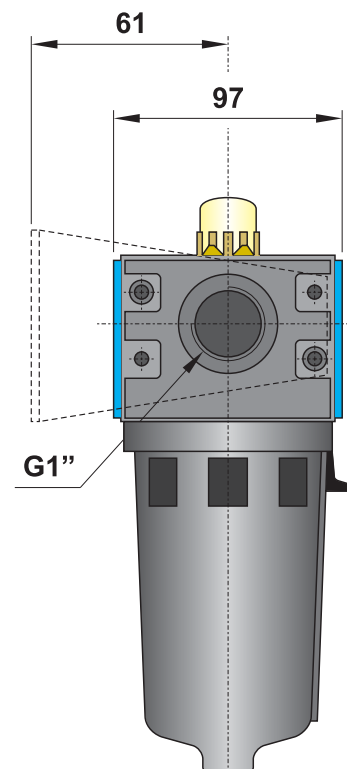
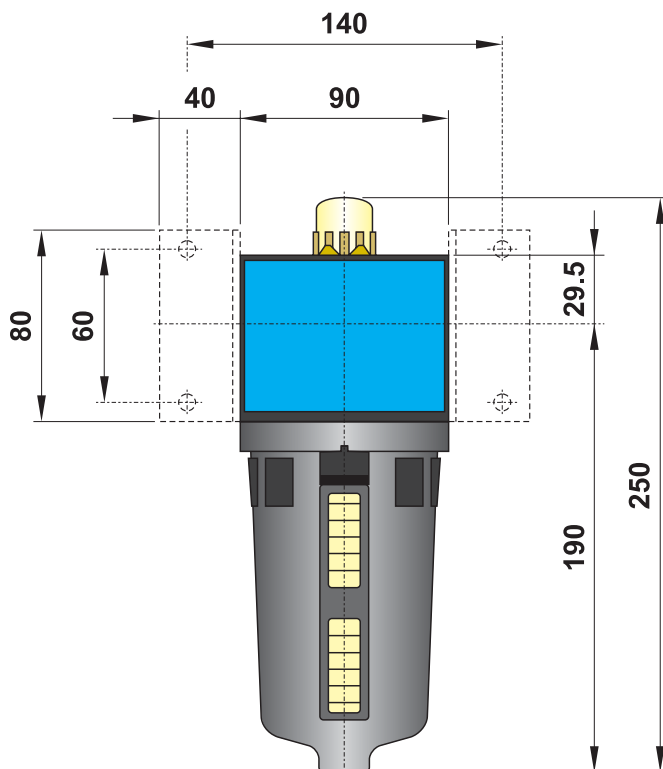
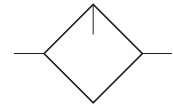

Condizioni minime di operatività
Minimum operating conditions

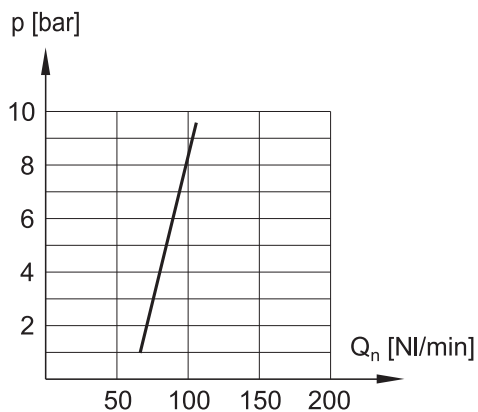

Materiali

Corpo: alluminio pressofuso

Guarnizioni: NBR

Parti interne: ottone e INOX

Parti esterne: polimeri rinforzati

Tazza: metallica

Materials

Body: die-cast aluminium

Seals: NBR

Internal parts: brass and stainless steel

External parts: reinforced polymer

Bowl: metal

filtratore regolatore G1/4"

G1/4" filter-regulator



- Sistema di funzionamento: gruppo ciclone ed elemento filtrante, combinato con regolatore di pressione a pistone dotato di valvola di scarico sovrappressione (relieving)
Cyclone system and filter element, combined with piston-type pressure regulator (with relieving)
- Separazione condensa: > 90%
Moisture separation: > 90%
- Scarico semiautomatico della condensa
Semi-automatic moisture exhaust
- Capacità della tazza: 12 cm³; protezione in plastica a richiesta (cod. PR 2-00)
Bowl capacity: 12 cm³; plastic bowl protection on request (code PR 2-00)
- Installazione verticale; staffa di fissaggio a richiesta (cod. STF 2)
Vertical installation; bracket on request (code STF 2)



CODICE DI ORDINAZIONE ORDER CODE		FR 2-08-25-S	FR 2-08-05-S
Attacchi Ports		G1/4"	G1/4"
Temperatura di esercizio Temperature range		max +50°C	max +50°C
Peso Weight		0.12 kg	0.12 kg
Pressione di alimentazione Inlet pressure range	$p_{1 \text{ min}}$ $p_{1 \text{ max}}$	0 bar; 0 MPa 10 bar; 1 MPa	0 bar; 0 MPa 10 bar; 1 MPa
Pressione di utilizzo Outlet pressure range	$p_{2 \text{ min}}$ $p_{2 \text{ max}}$	0.5 bar; 0.05 MPa 8 bar; 0.8 MPa	0.5 bar; 0.05 MPa 8 bar; 0.8 MPa
Differenza minima di pressione (Δp) Minimum pressure difference (Δp)	$p_1 - p_2$	0.2 bar; 0.02 MPa	0.2 bar; 0.02 MPa
Isteresi Hysteresis	$p_1 = 10 \text{ bar} / p_2 = 0 \text{ bar}$ $p_1 = 10 \text{ bar} / p_2 = 8 \text{ bar}$	1.6 0.6	1.6 0.6
Portata raccomandata Recommended flow rate	$p_2 = 6.3 \text{ bar a } 25 \text{ m/s}$ $p_2 = 6.3 \text{ bar at } 25 \text{ m/s}$	Q_n	Q_n
Elemento filtrante Filter element		25 μm	5 μm

5

Caratteristiche di portata
Flow characteristics

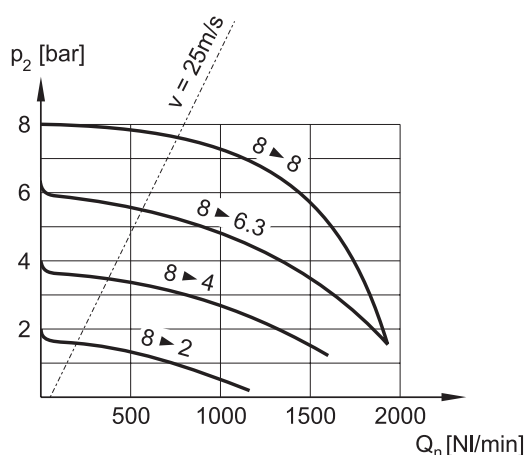

Variazione della pressione di utilizzo in presenza di fluttuazioni della pressione di alimentazione
Outlet pressure variation with fluctuating inlet pressure

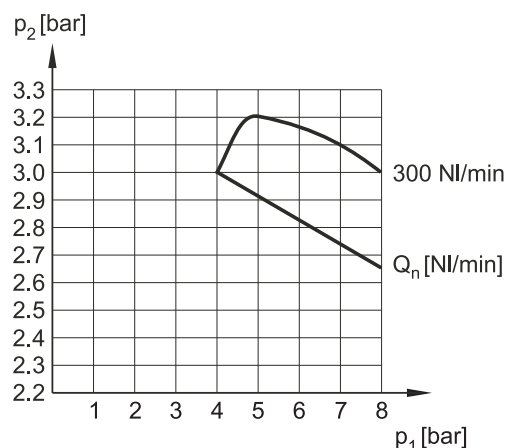

filtratore regolatore G1/4"

G1/4" filter-regulator



La staffa di fissaggio e il manometro devono essere acquistati separatamente.
Mounting bracket and manometer are bought separately.

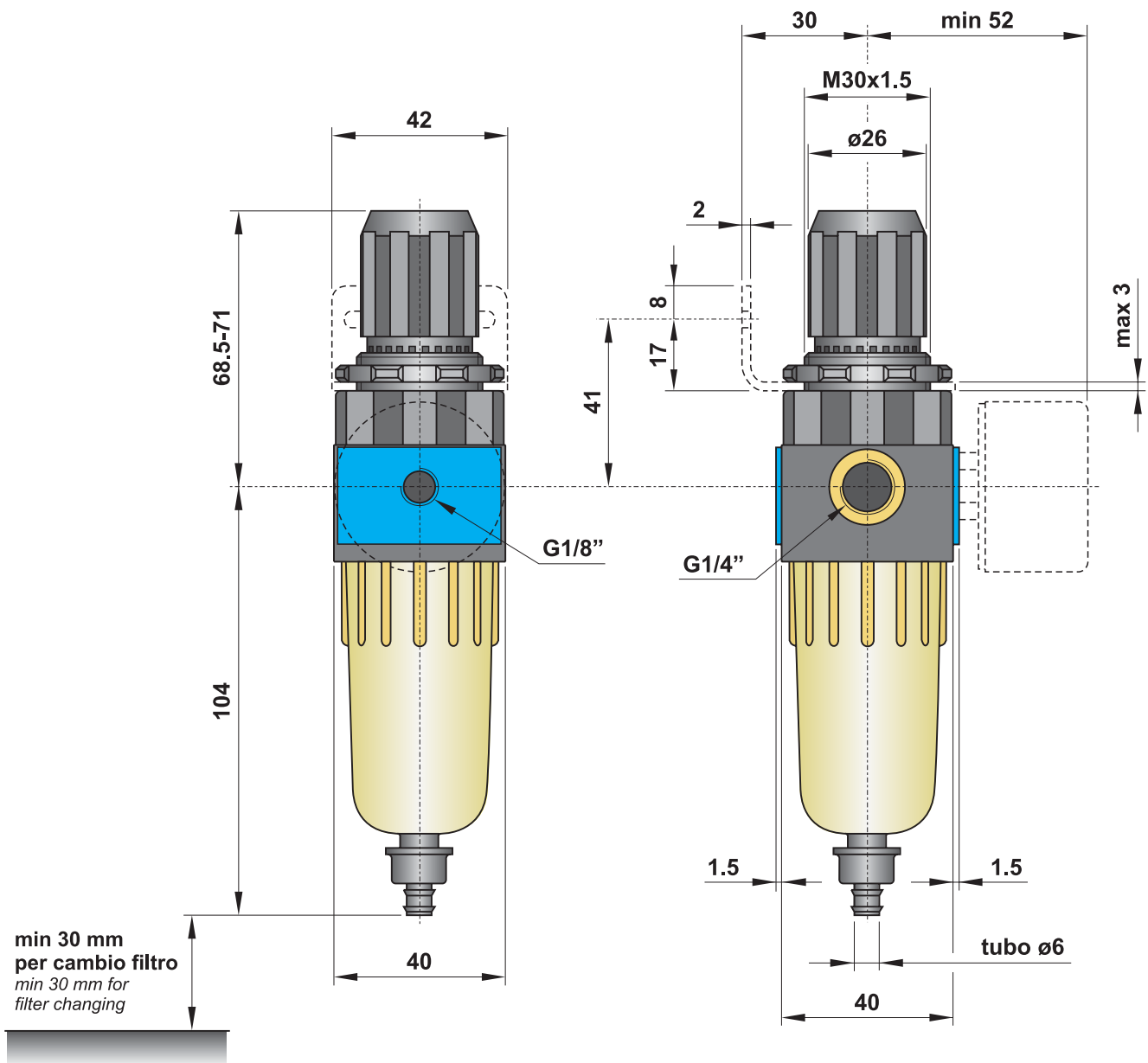
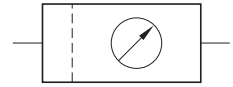

Materiali

Corpo: polimero rinforzato con inserti filettati in ottone

Molle: INOX

Guarnizioni: NBR

Parti interne: ottone, INOX e polimeri

Tazza: policarbonato rinforzato

Materials

Body: reinforced polymer with brass thread inserts

Springs: stainless steel

Seals: NBR

Internal parts: brass, stainless steel and polymer

Bowl: reinforced polycarbonate

filtratore regolatore G3/8"

G3/8" filter-regulator



- Sistema di funzionamento: gruppo ciclone ed elemento filtrante, combinato con regolatore di pressione a diaframma dotato di valvola di scarico sovrappressione (relieving)
Cyclone system and filter element, combined with diaphragm-type pressure regulator (with relieving)
- Separazione condensa: > 90%
Moisture separation: > 90%
- Scarico semiautomatico della condensa; automatico a richiesta
Semi-automatic moisture exhaust; automatic on request
- Capacità della tazza: 22 cm³; protezione metallica della tazza a richiesta (cod. PR 3-00)
Bowl capacity: 22 cm³; metal bowl protection on request (code PR 3-00)
- Installazione verticale; staffa di fissaggio a richiesta (cod. STF 3 o STF 3A)
Vertical installation; bracket on request (code STF 3 or STF 3A)



CODICE DI ORDINAZIONE ORDER CODE		FR 3-08-30-S	FR 3-08-05-S
Attacchi Ports		G3/8"	G3/8"
Temperatura di esercizio Temperature range		max +50°C	max +50°C
Peso Weight		0.35 kg	0.35 kg
Pressione di alimentazione Inlet pressure range	$p_{1 \text{ min}}$ $p_{1 \text{ max}}$	0 bar; 0 MPa 16 bar; 1.6 MPa	0 bar; 0 MPa 16 bar; 1.6 MPa
Pressione di utilizzo Outlet pressure range	$p_{2 \text{ min}}$ $p_{2 \text{ max}}$	0.5 bar; 0.05 MPa 8 bar; 0.8 MPa	0.5 bar; 0.05 MPa 8 bar; 0.8 MPa
Differenza minima di pressione (Δp) Minimum pressure difference (Δp)	$p_1 - p_2$	0.2 bar; 0.02 MPa	0.2 bar; 0.02 MPa
Isteresi Hysteresis	$p_1 = 10 \text{ bar} / p_2 = 0 \text{ bar}$ $p_1 = 10 \text{ bar} / p_2 = 8 \text{ bar}$	0.5 0.4	0.5 0.4
Portata raccomandata Recommended flow rate	$p_2 = 6 \text{ bar a } 25 \text{ m/s}$ $p_2 = 6 \text{ bar at } 25 \text{ m/s}$	Q_n	Q_n
Elemento filtrante Filter element		30 μm	5 μm

Caratteristiche di portata
Flow characteristics

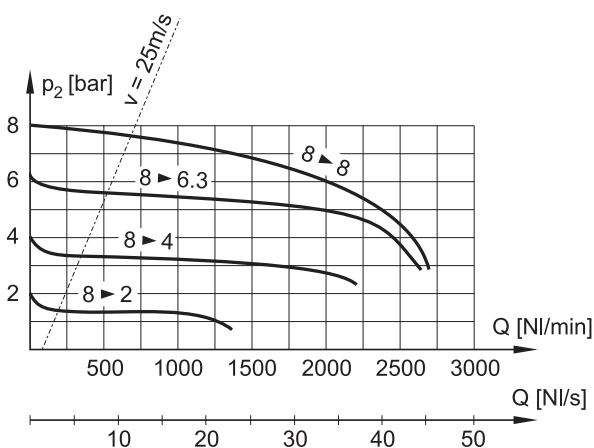

Variazione della pressione di utilizzo in presenza di fluttuazioni della pressione di alimentazione
Outlet pressure variation with fluctuating inlet pressure

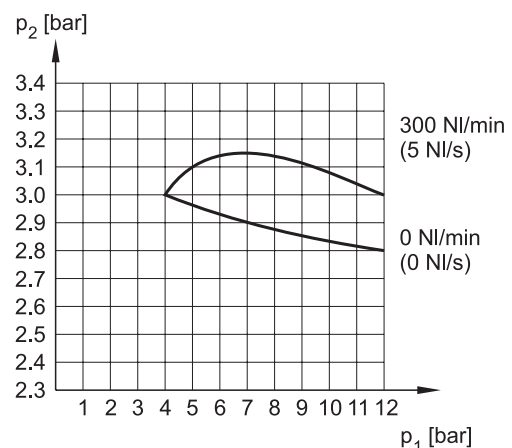

filtrorregolatore G3/8"

G3/8" filter-regulator



La staffa di fissaggio, la ghiera e il manometro devono essere acquistati separatamente.
Mounting bracket, ring and manometer are bought separately.

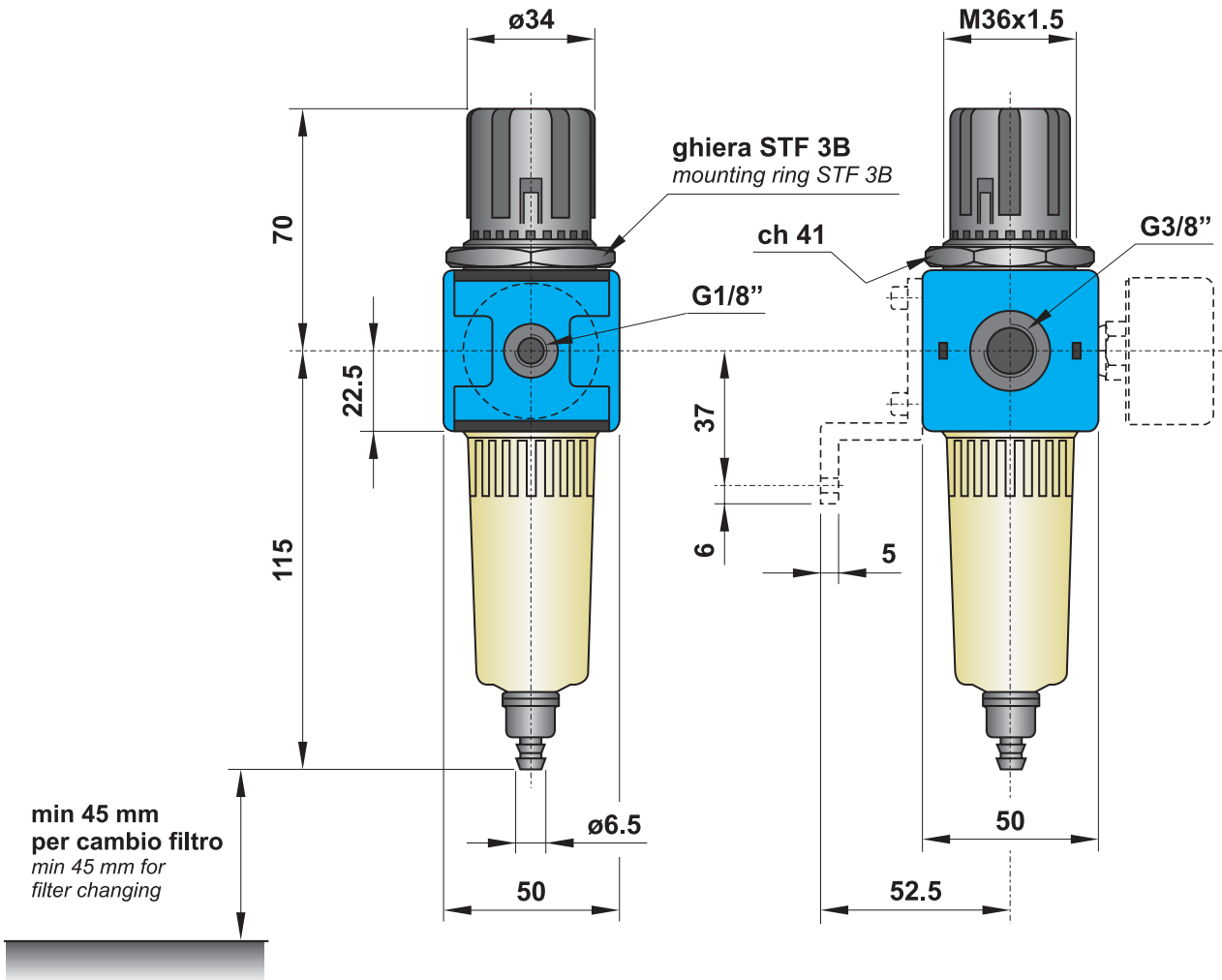
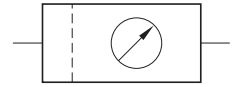

Materiali

Corpo: alluminio pressofuso

Guarnizioni: NBR

Parti interne: ottone e INOX

Parti esterne: polimeri rinforzati

Tazza: policarbonato rinforzato

Materials

Body: die-cast aluminium

Seals: NBR

Internal parts: brass and stainless steel

External parts: reinforced polymer

Bowl: reinforced polycarbonate

filtratore regolatore G1/2"

G1/2" filter-regulator



- Sistema di funzionamento: gruppo ciclone ed elemento filtrante, combinato con regolatore di pressione a diaframma dotato di valvola di scarico sovrappressione (relieving)
Cyclone system and filter element, combined with diaphragm-type pressure regulator (with relieving)
- Separazione condensa: 95%
Moisture separation: 95%
- Scarico semiautomatico della condensa; automatico a richiesta
Semi-automatic moisture exhaust; automatic on request
- Capacità della tazza: 57 cm³; protezione metallica della tazza a richiesta (cod. PR 4-00)
Bowl capacity: 57 cm³; metal bowl protection on request (code PR 4-00)
- Installazione verticale; staffa di fissaggio a richiesta (cod. STF 4)
Vertical installation; bracket on request (code STF 4)



CODICE DI ORDINAZIONE ORDER CODE		FR 4-08-30-S	FR 4-08-05-S
Attacchi Ports		G1/2"	G1/2"
Temperatura di esercizio Temperature range		max +50°C	max +50°C
Peso Weight		0.75 kg	0.75 kg
Pressione di alimentazione Inlet pressure range	$p_{1 \min}$ $p_{1 \max}$	0 bar; 0 MPa 16 bar; 1.6 MPa	0 bar; 0 MPa 16 bar; 1.6 MPa
Pressione di utilizzo Outlet pressure range	$p_{2 \min}$ $p_{2 \max}$	0.5 bar; 0.05 MPa 8 bar; 0.8 MPa	0.5 bar; 0.05 MPa 8 bar; 0.8 MPa
Differenza minima di pressione (Δp) Minimum pressure difference (Δp)	$p_1 - p_2$	0.2 bar; 0.02 MPa	0.2 bar; 0.02 MPa
Isteresi Hysteresis	$p_1 = 10 \text{ bar} / p_2 = 0 \text{ bar}$ $p_1 = 10 \text{ bar} / p_2 = 8 \text{ bar}$	0.9 0.7	0.9 0.7
Portata raccomandata Recommended flow rate	$p_2 = 6 \text{ bar a } 25 \text{ m/s}$ $p_2 = 6 \text{ bar at } 25 \text{ m/s}$	Q_n 1900 NI/min (max 3300 NI/min)	1900 NI/min (max 3300 NI/min)
Elemento filtrante Filter element		30 μm	5 μm

Caratteristiche di portata
Flow characteristics

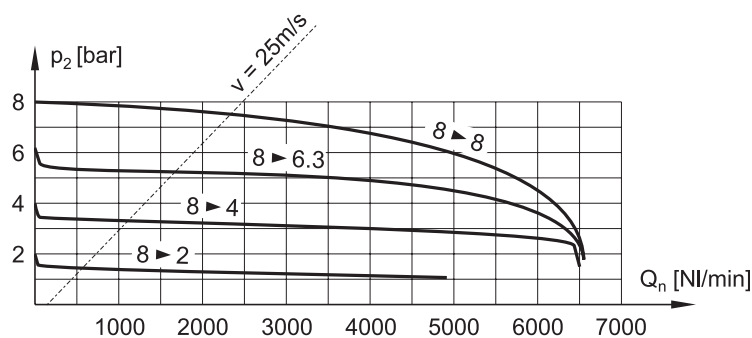

Variazione della pressione di utilizzo in presenza di fluttuazioni della pressione di alimentazione
Outlet pressure variation with fluctuating inlet pressure

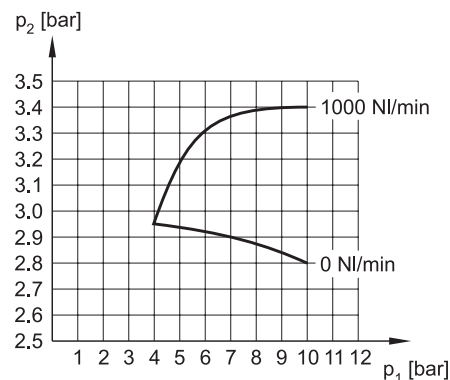

filtratore regolatore G1/2"

G1/2" filter-regulator



La staffa di fissaggio e il manometro devono essere acquistati separatamente.
Mounting bracket and manometer are bought separately.

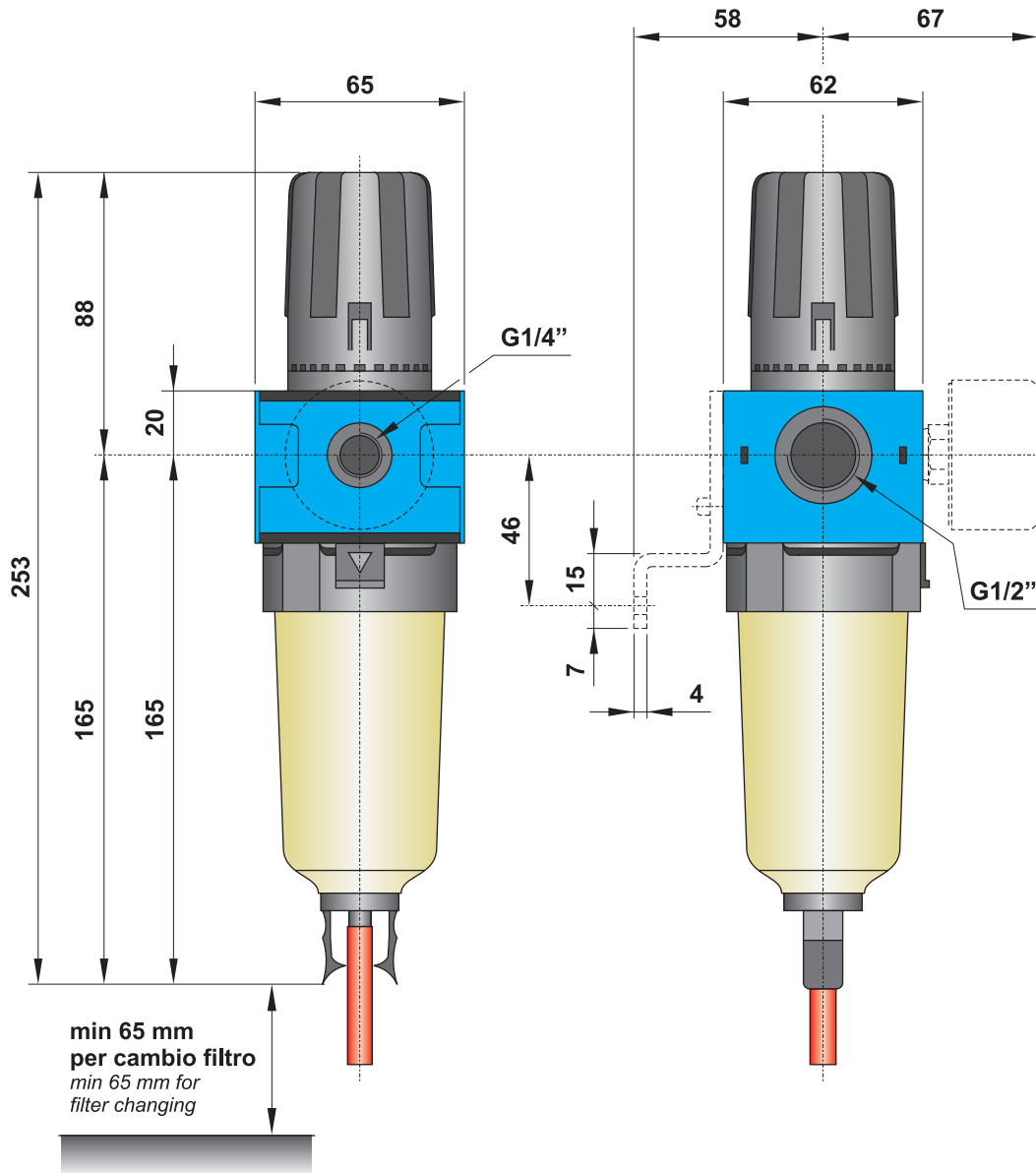

Materiali

Corpo: alluminio pressofuso

Guarnizioni: NBR

Parti interne: ottone e INOX

Parti esterne: polimeri rinforzati

Tazza: policarbonato rinforzato

Materials

Body: die-cast aluminium

Seals: NBR

Internal parts: brass and stainless steel

External parts: reinforced polymer

Bowl: reinforced polycarbonate

filtratore regolatore G1"

G1" filter-regulator



- Sistema di funzionamento: gruppo ciclone ed elemento filtrante, combinato con regolatore di pressione a diaframma dotato di valvola di scarico sovrappressione (relieving)
Cyclone system and filter element, combined with diaphragm-type pressure regulator (with relieving)
- Separazione condensa: 96%
Moisture separation: 96%
- Scarico semiautomatico della condensa; automatico a richiesta
Semi-automatic moisture exhaust; automatic on request
- Capacità della tazza: 500 cm³; tazza metallica
Bowl capacity: 500 cm³; metal bowl
- Installazione verticale; staffe di fissaggio a richiesta (cod. STF 6)
Vertical installation; brackets on request (code STF 6)



CODICE DI ORDINAZIONE ORDER CODE		FR 6-10-30-S	FR 6-10-05-S
Attacchi Ports		G1"	G1"
Temperatura di esercizio Temperature range		max +50°C	max +50°C
Peso Weight		2.8 kg	2.8 kg
Pressione di alimentazione Inlet pressure range	$p_{1 \text{ min}}$ $p_{1 \text{ max}}$	0 bar; 0 MPa 10 bar; 1 MPa	0 bar; 0 MPa 10 bar; 1 MPa
Pressione di utilizzo Outlet pressure range	$p_{2 \text{ min}}$ $p_{2 \text{ max}}$	0.5 bar; 0.05 MPa 10 bar; 1 MPa	0.5 bar; 0.05 MPa 10 bar; 1 MPa
Differenza minima di pressione (Δp) Minimum pressure difference (Δp)	$p_1 - p_2$	0.2 bar; 0.02 MPa	0.2 bar; 0.02 MPa
Isteresi Hysteresis	$p_1 = 10 \text{ bar} / p_2 = 0 \text{ bar}$ $p_1 = 10 \text{ bar} / p_2 = 8 \text{ bar}$	0.6 0.3	0.6 0.3
Portata raccomandata Recommended flow rate	$p_2 = 6 \text{ bar a } 25 \text{ m/s}$ $p_2 = 6 \text{ bar at } 25 \text{ m/s}$	Q_n	Q_n
Elemento filtrante Filter element		30 μm	5 μm

Caratteristiche di portata
Flow characteristics

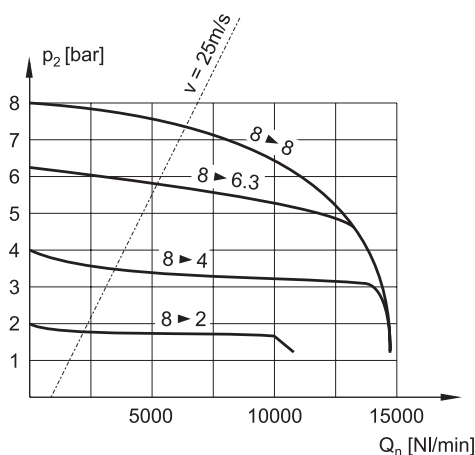

Variazione della pressione di utilizzo in presenza di fluttuazioni della pressione di alimentazione
Outlet pressure variation with fluctuating inlet pressure

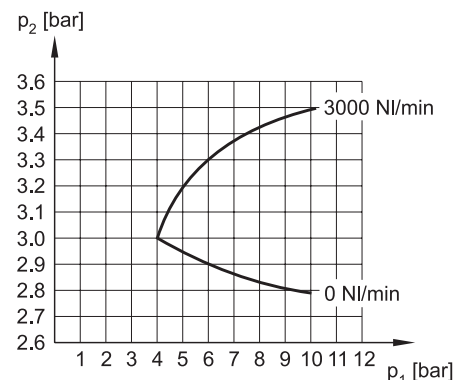

filtrorregolatore G1"

G1" filter-regulator



Le staffe di fissaggio e il manometro devono essere acquistati separatamente.
Mounting brackets and manometer are bought separately.

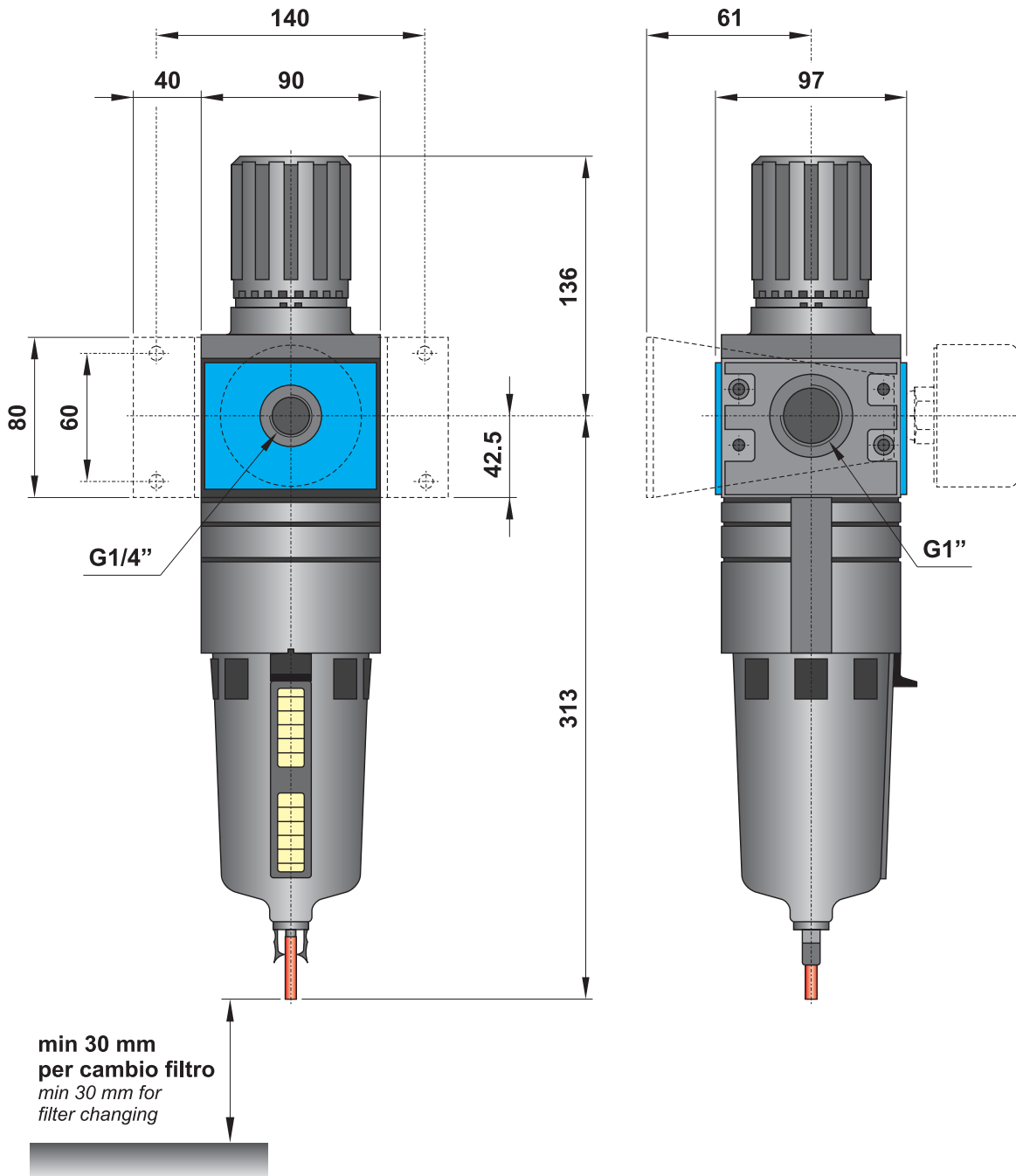
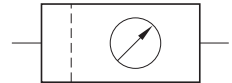

Materiali

Corpo: alluminio pressofuso

Guarnizioni: NBR

Parti interne: ottone e INOX

Parti esterne: polimeri rinforzati

Tazza: metallica

Materials

Body: die-cast aluminium

Seals: NBR

Internal parts: brass and stainless steel

External parts: reinforced polymer

Bowl: metal

gruppo trattamento aria FR+L G1/4"

G1/4" FR+L air preparation unit



- Il gruppo comprende: filtroregolatore e lubrificatore
The unit includes: filter-regulator and oil mist lubricator
- Separazione condensa: > 90%
Moisture separation: > 90%
- Scarico semiautomatico della condensa; rifornimento olio manuale
Semi-automatic moisture exhaust; manual oil refilling
- Capacità delle tazze: 12 cm³ (condensa), 35 cm³ (olio)
Bowl capacity: 12 cm³ (moisture), 35 cm³ (oil)
- Installazione verticale; staffa di fissaggio a richiesta (cod. STF 2)
Vertical installation; bracket on request (code STF 2)



CODICE DI ORDINAZIONE ORDER CODE		FR+L 2-08-25-S
Attacchi <i>Ports</i>		G1/4"
Temperatura di esercizio <i>Temperature range</i>		max +50°C
Peso <i>Weight</i>		0.32 kg
Pressione di alimentazione <i>Inlet pressure range</i>	$p_{1 \text{ min}}$ $p_{1 \text{ max}}$	0 bar; 0 MPa 10 bar; 1 MPa
Pressione di utilizzo <i>Outlet pressure range</i>	$p_{2 \text{ min}}$ $p_{2 \text{ max}}$	0.5 bar; 0.05 MPa 8 bar; 0.8 MPa
Differenza minima di pressione (Δp) <i>Minimum pressure difference (Δp)</i>	$p_1 - p_2$	0.2 bar; 0.02 MPa
Isteresi <i>Hysteresis</i>	$p_1 = 10 \text{ bar} / p_2 = 0 \text{ bar}$ $p_1 = 10 \text{ bar} / p_2 = 8 \text{ bar}$	1.6 0.6
Portata raccomandata <i>Recommended flow rate</i>	$p_2 = 6.3 \text{ bar a } 25 \text{ m/s}$ $p_2 = 6.3 \text{ bar at } 25 \text{ m/s}$	Q_n 550 NI/min
Elemento filtrante <i>Filter element</i>		25 μm

Caratteristiche di portata
Flow characteristics

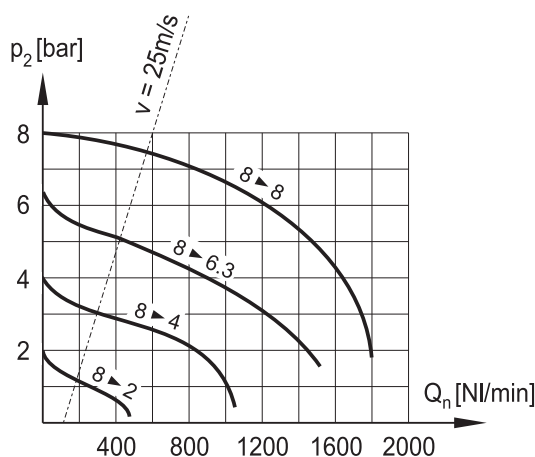

gruppo trattamento aria FR+L G1/4"

G1/4" FR+L air preparation unit



La staffa di fissaggio e il manometro devono essere acquistati separatamente.
Mounting bracket and manometer are bought separately.

Protezione in plastica della tazza a richiesta (cod. PR 2-00)
Plastic bowl protection on request (code PR 2-00)

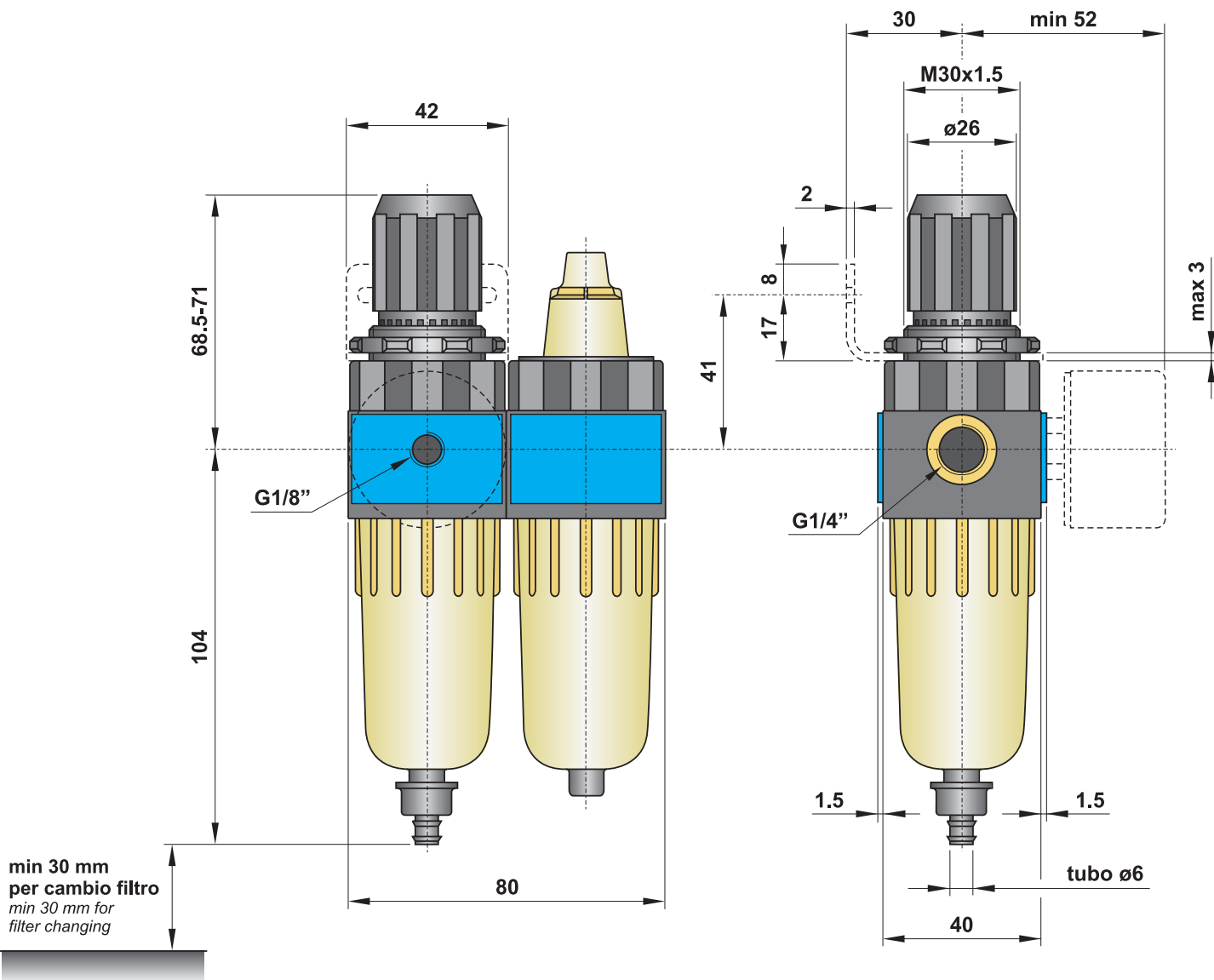
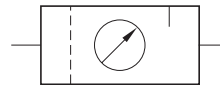

Materiali

Corpo: polimero rinforzato con inserti filettati in ottone

Molle: INOX

Guarnizioni: NBR

Parti interne: ottone, INOX e polimeri

Tazze: policarbonato rinforzato

Materials

Body: reinforced polymer with brass thread inserts

Springs: stainless steel

Seals: NBR

Internal parts: brass, stainless steel and polymer

Bowls: reinforced polycarbonate

gruppo trattamento aria FR+L G3/8"

G3/8" FR+L air preparation unit



- Il gruppo comprende: filtroregolatore e lubrificatore
The unit includes: filter-regulator and oil mist lubricator
- Separazione condensa: > 90%
Moisture separation: > 90%
- Scarico semiautomatico della condensa; rifornimento olio manuale
Semi-automatic moisture exhaust; manual oil refilling
- Capacità delle tazze: 22 cm³ (condensa), 45 cm³ (olio)
Bowl capacity: 22 cm³ (moisture), 45 cm³ (oil)
- Installazione verticale; staffa di fissaggio a richiesta (cod. STF 3 o STF 3A)
Vertical installation; bracket on request (code STF 3 or STF 3A)
- Protezione metallica della tazza a richiesta (cod. PR 3-00)
Metal bowl protection on request (code PR 3-00)



CODICE DI ORDINAZIONE <i>ORDER CODE</i>		FR+L 3-08-30-S
Attacchi <i>Ports</i>		G3/8"
Temperatura di esercizio <i>Temperature range</i>		max +50°C
Peso <i>Weight</i>		0.75 kg
Pressione di alimentazione <i>Inlet pressure range</i>	$p_{1 \min}$ $p_{1 \max}$	0 bar; 0 MPa 16 bar; 1.6 MPa
Pressione di utilizzo <i>Outlet pressure range</i>	$p_{2 \min}$ $p_{2 \max}$	0.5 bar; 0.05 MPa 8 bar; 0.8 MPa
Differenza minima di pressione (Δp) <i>Minimum pressure difference (Δp)</i>	$p_1 - p_2$	0.2 bar; 0.02 MPa
Isteresi <i>Hysteresis</i>	$p_1 = 10 \text{ bar} / p_2 = 0 \text{ bar}$ $p_1 = 10 \text{ bar} / p_2 = 8 \text{ bar}$	0.5 0.4
Portata raccomandata <i>Recommended flow rate</i>	$p_2 = 6 \text{ bar a } 25 \text{ m/s}$ $p_2 = 6 \text{ bar at } 25 \text{ m/s}$	Q_n 680 NI/min
Elemento filtrante <i>Filter element</i>		30 μm

Caratteristiche di portata
Flow characteristics

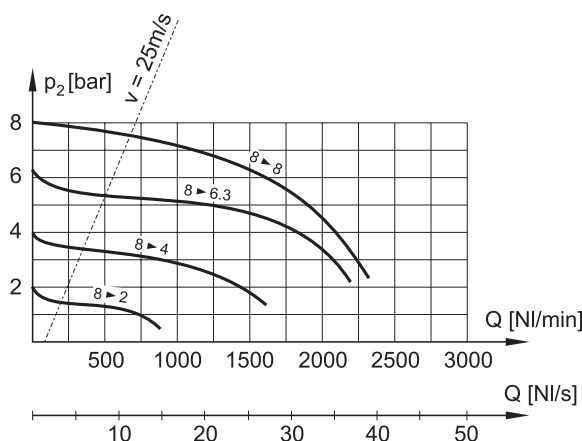

gruppo trattamento aria FR+L G3/8"

G3/8" FR+L air preparation unit



La staffa di fissaggio, la ghiera e il manometro devono essere acquistati separatamente.
Mounting bracket, ring and manometer are bought separately.

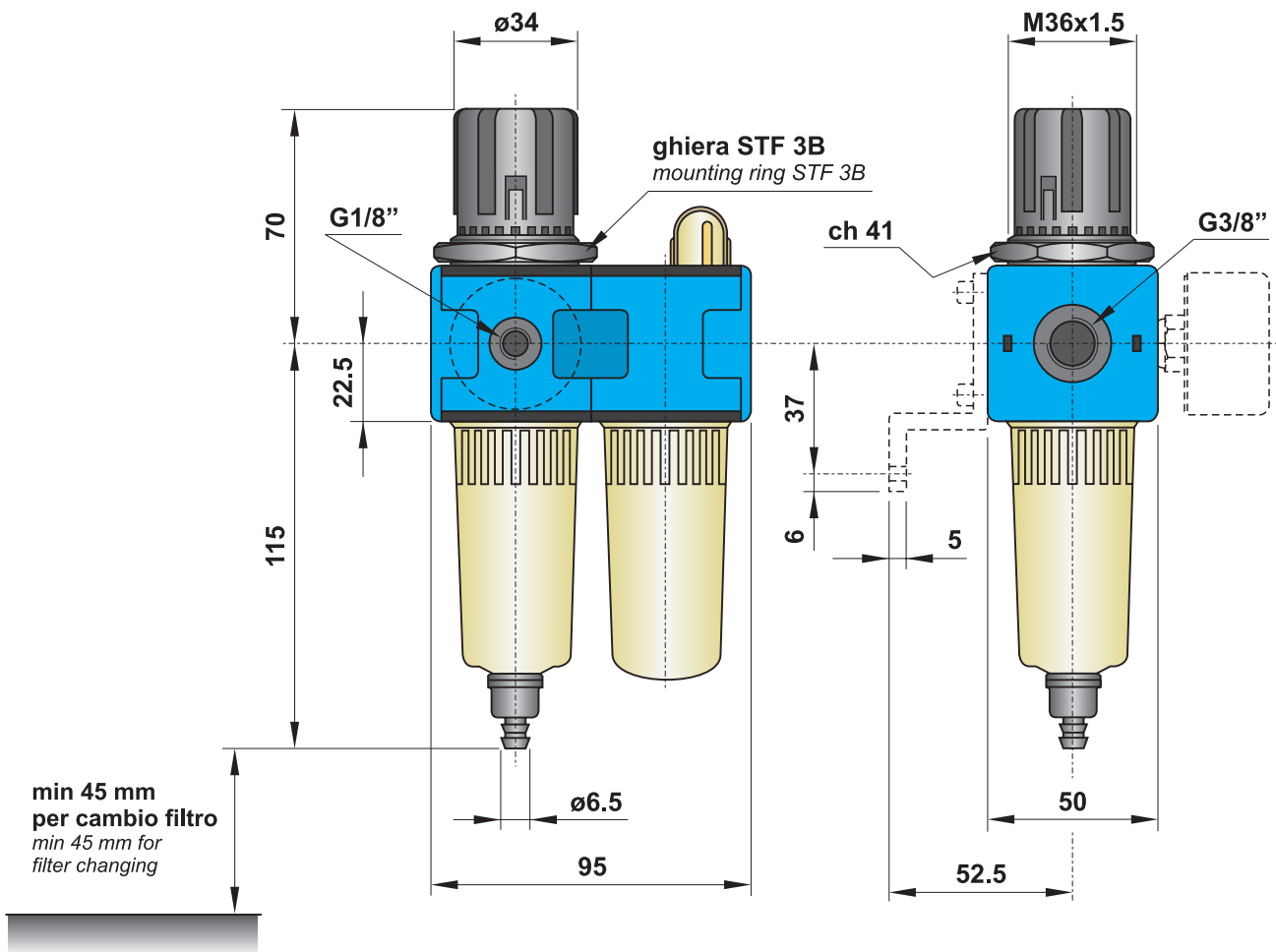
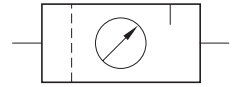

Materiali

Corpo: alluminio pressofuso

Guarnizioni: NBR

Parti interne: ottone e INOX

Parti esterne: polimeri rinforzati

Tazze: policarbonato rinforzato

Materials

Body: die-cast aluminium

Seals: NBR

Internal parts: brass and stainless steel

External parts: reinforced polymer

Bowls: reinforced polycarbonate

gruppo trattamento aria FR+L G1/2"

G1/2" FR+L air preparation unit



- Il gruppo comprende: filtroregolatore e lubrificatore
The unit includes: filter-regulator and oil mist lubricator
- Separazione condensa: 95%
Moisture separation: 95%
- Scarico semiautomatico della condensa; rifornimento olio manuale
Semi-automatic moisture exhaust; manual oil refilling
- Capacità delle tazze: 57 cm³ (condensa), 112 cm³ (olio)
Bowl capacity: 57 cm³ (moisture), 112 cm³ (oil)
- Installazione verticale; staffa di fissaggio a richiesta (cod. STF 4)
Vertical installation; bracket on request (code STF 4)
- Protezione metallica della tazza a richiesta (cod. PR 4-00)
Metal bowl protection on request (code PR 4-00)



CODICE DI ORDINAZIONE <i>ORDER CODE</i>		FR+L 4-08-30-S
Attacchi <i>Ports</i>		G1/2"
Temperatura di esercizio <i>Temperature range</i>		max +50°C
Peso <i>Weight</i>		1.5 kg
Pressione di alimentazione <i>Inlet pressure range</i>	$p_{1 \text{ min}}$ $p_{1 \text{ max}}$	0 bar; 0 MPa 16 bar; 1.6 MPa
Pressione di utilizzo <i>Outlet pressure range</i>	$p_{2 \text{ min}}$ $p_{2 \text{ max}}$	0.5 bar; 0.05 MPa 8 bar; 0.8 MPa
Differenza minima di pressione (Δp) <i>Minimum pressure difference (Δp)</i>	$p_1 - p_2$	0.2 bar; 0.02 MPa
Isteresi <i>Hysteresis</i>	$p_1 = 10 \text{ bar} / p_2 = 0 \text{ bar}$ $p_1 = 10 \text{ bar} / p_2 = 8 \text{ bar}$	0.9 0.7
Portata raccomandata <i>Recommended flow rate</i>	$p_2 = 6 \text{ bar a } 25 \text{ m/s}$ $p_2 = 6 \text{ bar at } 25 \text{ m/s}$	Q_n 1900 NI/min
Elemento filtrante <i>Filter element</i>		30 μm

Caratteristiche di portata
Flow characteristics

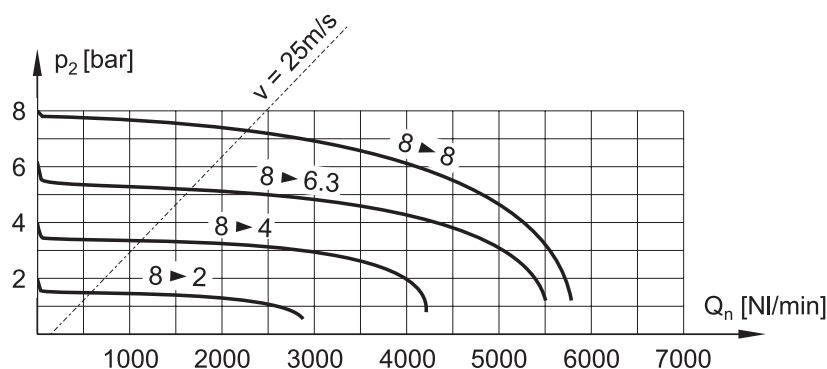

gruppo trattamento aria FR+L G1/2"

G1/2" FR+L air preparation unit



La staffa di fissaggio e il manometro devono essere acquistati separatamente.
Mounting bracket and manometer are bought separately.

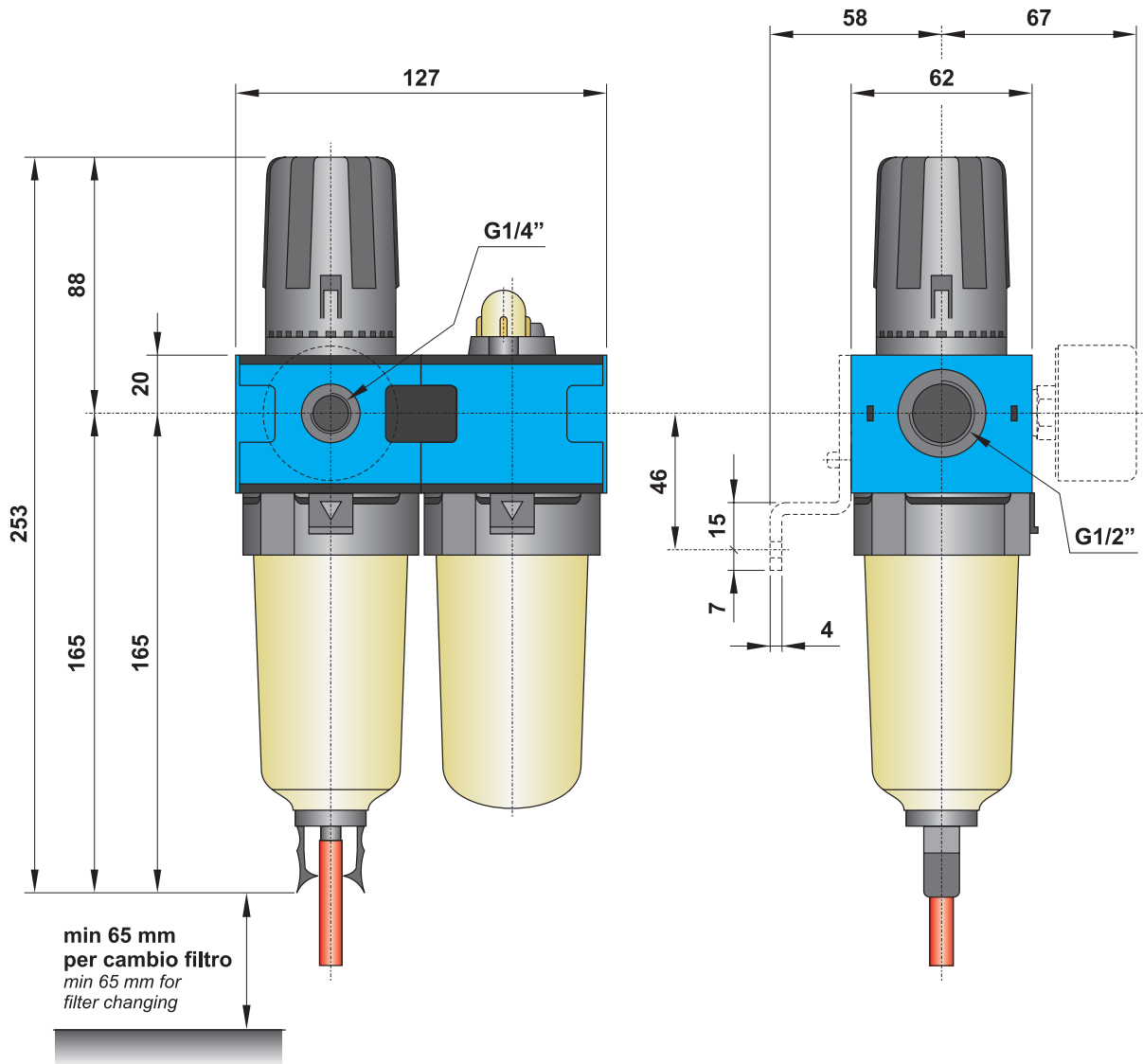
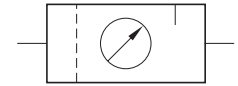

Materiali

Corpo: alluminio pressofuso

Guarnizioni: NBR

Parti interne: ottone e INOX

Parti esterne: polimeri rinforzati

Tazze: policarbonato rinforzato

Materials

Body: die-cast aluminium

Seals: NBR

Internal parts: brass and stainless steel

External parts: reinforced polymer

Bowls: reinforced polycarbonate

gruppo trattamento aria FR+L G1"

G1" FR+L air preparation unit



- Il gruppo comprende: filtroregolatore e lubrificatore
The unit includes: filter-regulator and oil mist lubricator
- Separazione condensa: 96%
Moisture separation: 96%
- Scarico semiautomatico della condensa; rifornimento olio manuale
Semi-automatic moisture exhaust; manual oil refilling
- Capacità delle tazze: 500 cm³ (condensa), 500 cm³ (olio)
Bowl capacity: 500 cm³ (moisture), 500 cm³ (oil)
- Installazione verticale; staffe di fissaggio a richiesta (cod. STF 6)
Vertical installation; brackets on request (code STF 6)
- Tazza metallica
Metal bowl



CODICE DI ORDINAZIONE <i>ORDER CODE</i>		FR+L 6-10-30-S	
Attacchi <i>Ports</i>		G1"	
Temperatura di esercizio <i>Temperature range</i>		max +50°C	
Peso <i>Weight</i>		4.4 kg	
Pressione di alimentazione <i>Inlet pressure range</i>	$p_{1 \text{ min}}$ $p_{1 \text{ max}}$	0 bar; 0 MPa 10 bar; 1 MPa	
Pressione di utilizzo <i>Outlet pressure range</i>	$p_{2 \text{ min}}$ $p_{2 \text{ max}}$	0.5 bar; 0.05 MPa 10 bar; 10 MPa	
Differenza minima di pressione (Δp) <i>Minimum pressure difference (Δp)</i>	$p_1 - p_2$	0.2 bar; 0.02 MPa	
Isteresi <i>Hysteresis</i>	$p_1 = 10 \text{ bar} / p_2 = 0 \text{ bar}$ $p_1 = 10 \text{ bar} / p_2 = 8 \text{ bar}$	0.6 0.3	
Portata raccomandata <i>Recommended flow rate</i>	$p_2 = 6 \text{ bar a } 25 \text{ m/s}$ $p_2 = 6 \text{ bar at } 25 \text{ m/s}$	Q_n	5000 NI/min (max 10000 NI/min)
Elemento filtrante <i>Filter element</i>		30 μm	

Caratteristiche di portata
Flow characteristics

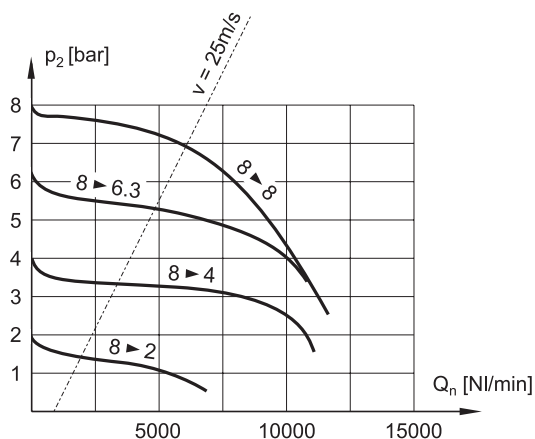

gruppo trattamento aria FR+L G1"

G1" FR+L air preparation unit



Le staffe di fissaggio e il manometro devono essere acquistati separatamente.
Mounting brackets and manometer are bought separately.

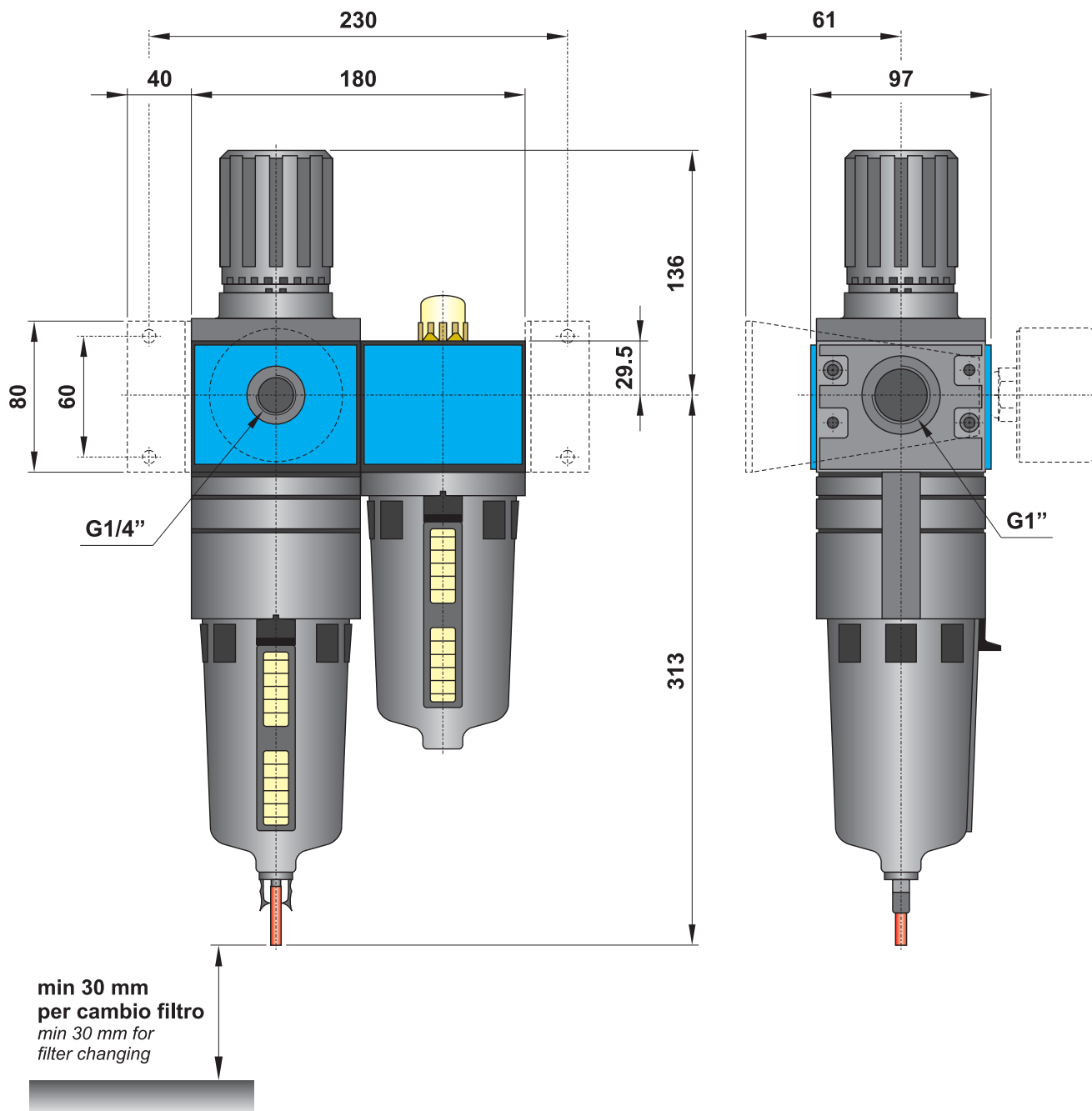
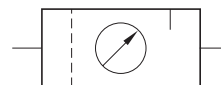

Materiali

Corpo: alluminio pressofuso

Guarnizioni: NBR

Parti interne: ottone e INOX

Parti esterne: polimeri rinforzati

Tazze: metalliche

Materials

Body: die-cast aluminium

Seals: NBR

Internal parts: brass and stainless steel

External parts: reinforced polymer

Bowls: metal

gruppo trattamento aria FRL G1/4"

G1/4" FRL air preparation unit



- Il gruppo comprende: filtro, regolatore di pressione e lubrificatore
The unit includes: filter, pressure regulator and oil mist lubricator
- Separazione condensa: > 90%
Moisture separation: > 90%
- Scarico semiautomatico della condensa; rifornimento olio manuale
Semi-automatic moisture exhaust; manual oil refilling
- Capacità delle tazze: 12 cm³ (condensa), 35 cm³ (olio)
Bowl capacity: 12 cm³ (moisture), 35 cm³ (oil)
- Installazione verticale; staffa di fissaggio a richiesta (cod. STF 2)
Vertical installation; bracket on request (code STF 2)



CODICE DI ORDINAZIONE ORDER CODE		FRL 2-08-25-S	
Attacchi Ports		G1/4"	
Temperatura di esercizio Temperature range		max +50°C	
Peso Weight		0.4 kg	
Pressione di alimentazione Inlet pressure range		$p_{1 \min}$ $p_{1 \max}$	0 bar; 0 MPa 10 bar; 1 MPa
Pressione di utilizzo Outlet pressure range		$p_{2 \min}$ $p_{2 \max}$	0.5 bar; 0.05 MPa 8 bar; 0.8 MPa
Differenza minima di pressione (Δp) Minimum pressure difference (Δp)		$p_1 - p_2$	0.2 bar; 0.02 MPa
Isteresi Hysteresis		$p_1 = 10 \text{ bar} / p_2 = 0 \text{ bar}$ $p_1 = 10 \text{ bar} / p_2 = 8 \text{ bar}$	1.6 0.6
Portata raccomandata Recommended flow rate	$p_2 = 6.3 \text{ bar a } 25 \text{ m/s}$ $p_2 = 6.3 \text{ bar at } 25 \text{ m/s}$	Q_n	550 NI/min
Elemento filtrante Filter element			25 μm

Caratteristiche di portata
Flow characteristics

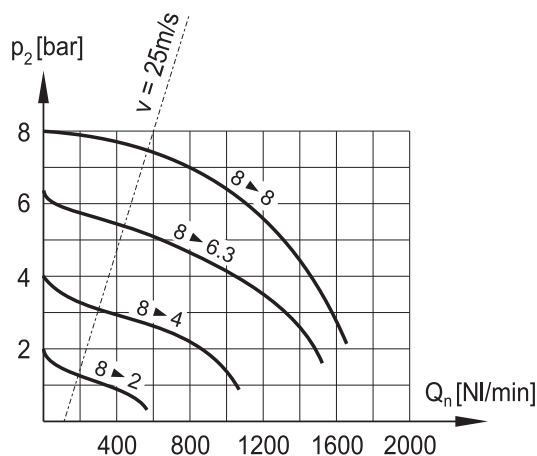

gruppo trattamento aria FRL G1/4"

G1/4" FRL air preparation unit



La staffa di fissaggio e il manometro devono essere acquistati separatamente.
Mounting bracket and manometer are bought separately.

Protezione in plastica della tazza a richiesta (cod. PR 2-00)
Plastic bowl protection on request (code PR 2-00)

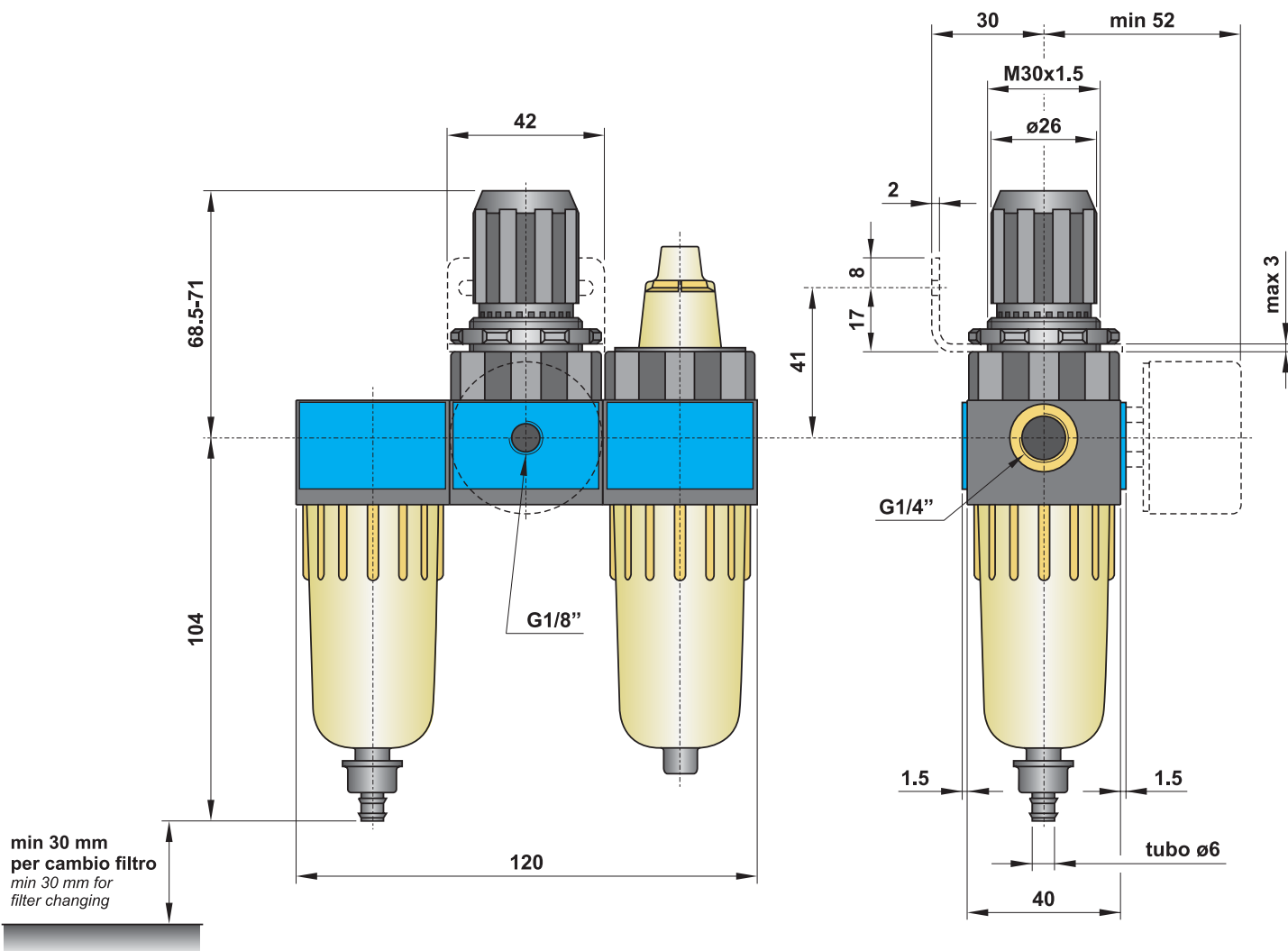
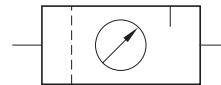

Materiali

Corpo: polimero rinforzato con inserti filettati in ottone

Molle: INOX

Guarnizioni: NBR

Parti interne: ottone, INOX e polimeri

Tazze: policarbonato rinforzato

Materials

Body: reinforced polymer with brass thread inserts

Springs: stainless steel

Seals: NBR

Internal parts: brass, stainless steel and polymer

Bowls: reinforced polycarbonate

gruppo trattamento aria FRL G3/8"

G3/8" FRL air preparation unit



- Il gruppo comprende: filtro, regolatore di pressione e lubrificatore
The unit includes: filter, pressure regulator and oil mist lubricator
- Separazione condensa: > 90%
Moisture separation: > 90%
- Scarico semiautomatico della condensa; rifornimento olio manuale
Semi-automatic moisture exhaust; manual oil refilling
- Capacità delle tazze: 22 cm³ (condensa), 45 cm³ (olio)
Bowl capacity: 22 cm³ (moisture), 45 cm³ (oil)
- Installazione verticale; staffa di fissaggio a richiesta (cod. STF 3 o STF 3A)
Vertical installation; bracket on request (code STF 3 or STF 3A)
- Protezione metallica della tazza a richiesta (cod. PR 3-00)
Metal bowl protection on request (code PR 3-00)



CODICE DI ORDINAZIONE <i>ORDER CODE</i>		FRL 3-08-30-S
Attacchi <i>Ports</i>		G3/8"
Temperatura di esercizio <i>Temperature range</i>		max +50°C
Peso <i>Weight</i>		0.95 kg
Pressione di alimentazione <i>Inlet pressure range</i>	$p_{1 \min}$ $p_{1 \max}$	0 bar; 0 MPa 16 bar; 1.6 MPa
Pressione di utilizzo <i>Outlet pressure range</i>	$p_{2 \min}$ $p_{2 \max}$	0.5 bar; 0.05 MPa 8 bar; 0.8 MPa
Differenza minima di pressione (Δp) <i>Minimum pressure difference (Δp)</i>	$p_1 - p_2$	0.2 bar; 0.02 MPa
Isteresi <i>Hysteresis</i>	$p_1 = 10 \text{ bar} / p_2 = 0 \text{ bar}$ $p_1 = 10 \text{ bar} / p_2 = 8 \text{ bar}$	0.5 0.4
Portata raccomandata <i>Recommended flow rate</i>	$p_2 = 6.3 \text{ bar a } 25 \text{ m/s}$ $p_2 = 6.3 \text{ bar at } 25 \text{ m/s}$	Q_n 680 NI/min
Elemento filtrante <i>Filter element</i>		30 μm

Caratteristiche di portata
Flow characteristics

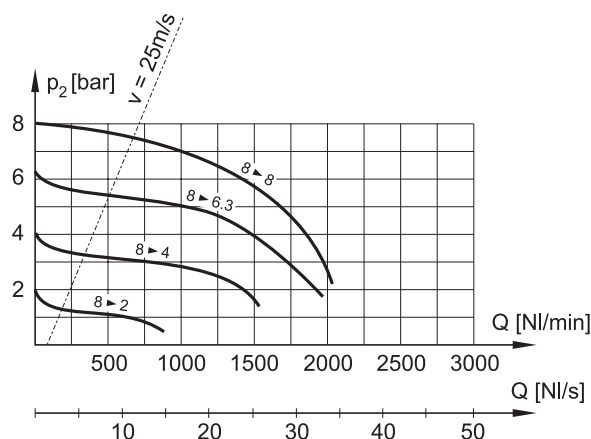

gruppo trattamento aria FRL G3/8"

G3/8" FRL air preparation unit



La staffa di fissaggio e il manometro devono essere acquistati separatamente.
Mounting bracket and manometer are bought separately.

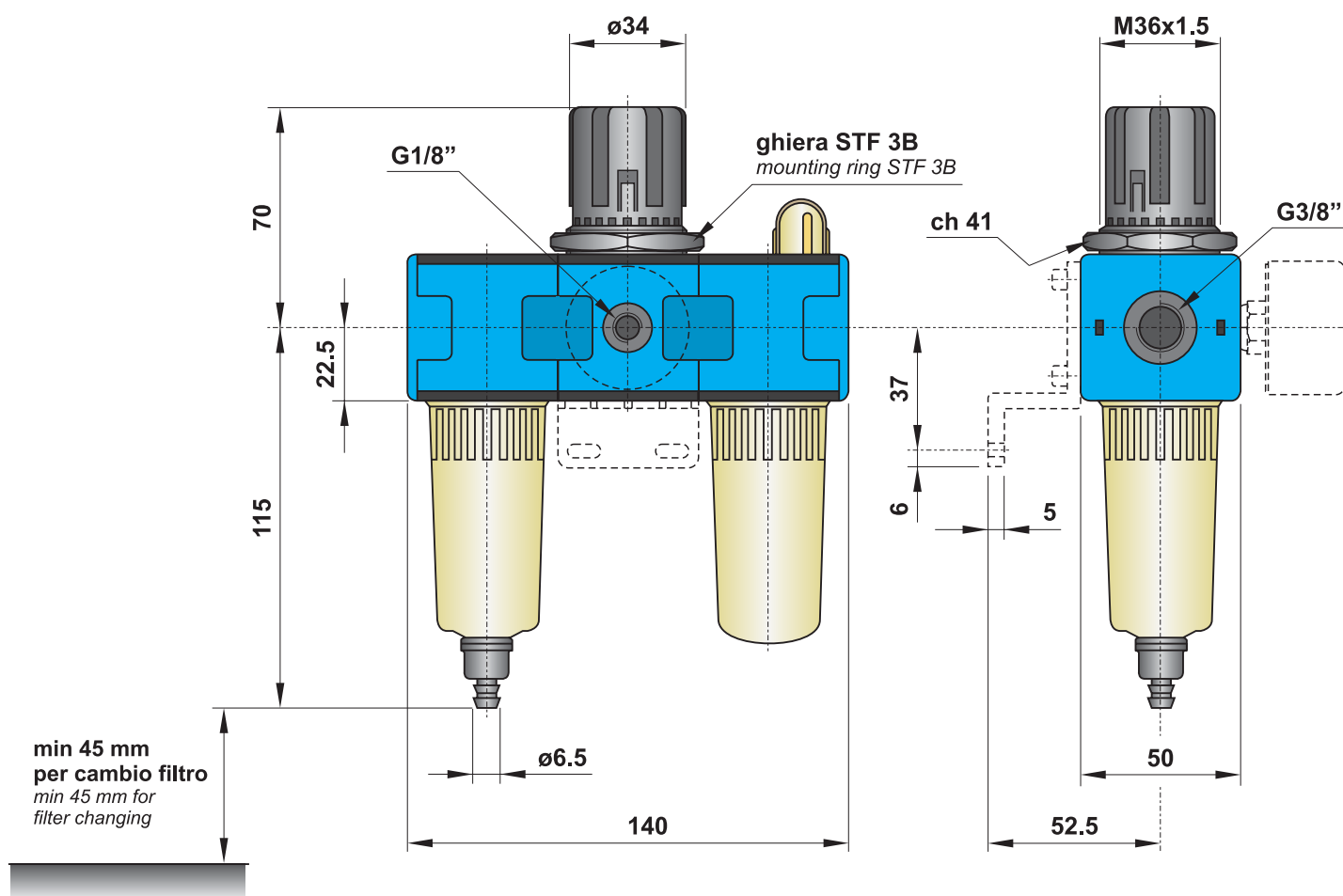
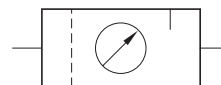

Materiali

Corpo: alluminio pressofuso

Guarnizioni: NBR

Parti interne: ottone e INOX

Parti esterne: polimeri rinforzati

Tazze: policarbonato rinforzato

Materials

Body: die-cast aluminium

Seals: NBR

Internal parts: brass and stainless steel

External parts: reinforced polymer

Bowls: reinforced polycarbonate

gruppo trattamento aria FRL G1/2"

G1/2" FRL air preparation unit



- Il gruppo comprende: filtro, regolatore di pressione e lubrificatore
The unit includes: filter, pressure regulator and oil mist lubricator
- Separazione condensa: 95%
Moisture separation: 95%
- Scarico semiautomatico della condensa; rifornimento olio manuale
Semi-automatic moisture exhaust; manual oil refilling
- Capacità delle tazze: 57 cm³ (condensa), 112 cm³ (olio)
Bowl capacity: 57 cm³ (moisture), 112 cm³ (oil)
- Installazione verticale; staffa di fissaggio a richiesta (cod. STF 4)
Vertical installation; bracket on request (code STF 4)
- Protezione metallica della tazza a richiesta (cod. PR 4-00)
Metal bowl protection on request (code PR 4-00)



CODICE DI ORDINAZIONE ORDER CODE		FRL 4-08-30-S
Attacchi <i>Ports</i>		G1/2"
Temperatura di esercizio <i>Temperature range</i>		max +50°C
Peso <i>Weight</i>		1.85 kg
Pressione di alimentazione <i>Inlet pressure range</i>	$p_{1 \text{ min}}$ $p_{1 \text{ max}}$	0 bar; 0 MPa 16 bar; 1.6 MPa
Pressione di utilizzo <i>Outlet pressure range</i>	$p_{2 \text{ min}}$ $p_{2 \text{ max}}$	0.5 bar; 0.05 MPa 8 bar; 0.8 MPa
Differenza minima di pressione (Δp) <i>Minimum pressure difference (Δp)</i>	$p_1 - p_2$	0.2 bar; 0.02 MPa
Isteresi <i>Hysteresis</i>	$p_1 = 10 \text{ bar} / p_2 = 0 \text{ bar}$ $p_1 = 10 \text{ bar} / p_2 = 8 \text{ bar}$	0.9 0.7
Portata raccomandata <i>Recommended flow rate</i>	$p_2 = 6.3 \text{ bar a } 25 \text{ m/s}$ $p_2 = 6.3 \text{ bar at } 25 \text{ m/s}$	Q_n 1900 NI/min
Elemento filtrante <i>Filter element</i>		30 μm

Caratteristiche di portata
Flow characteristics

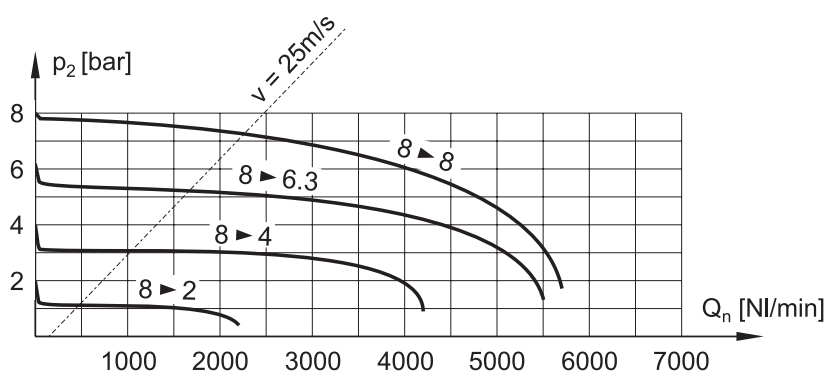

gruppo trattamento aria FRL G1/2"

G1/2" FRL air preparation unit



La staffa di fissaggio e il manometro devono essere acquistati separatamente.
Mounting bracket and manometer are bought separately.

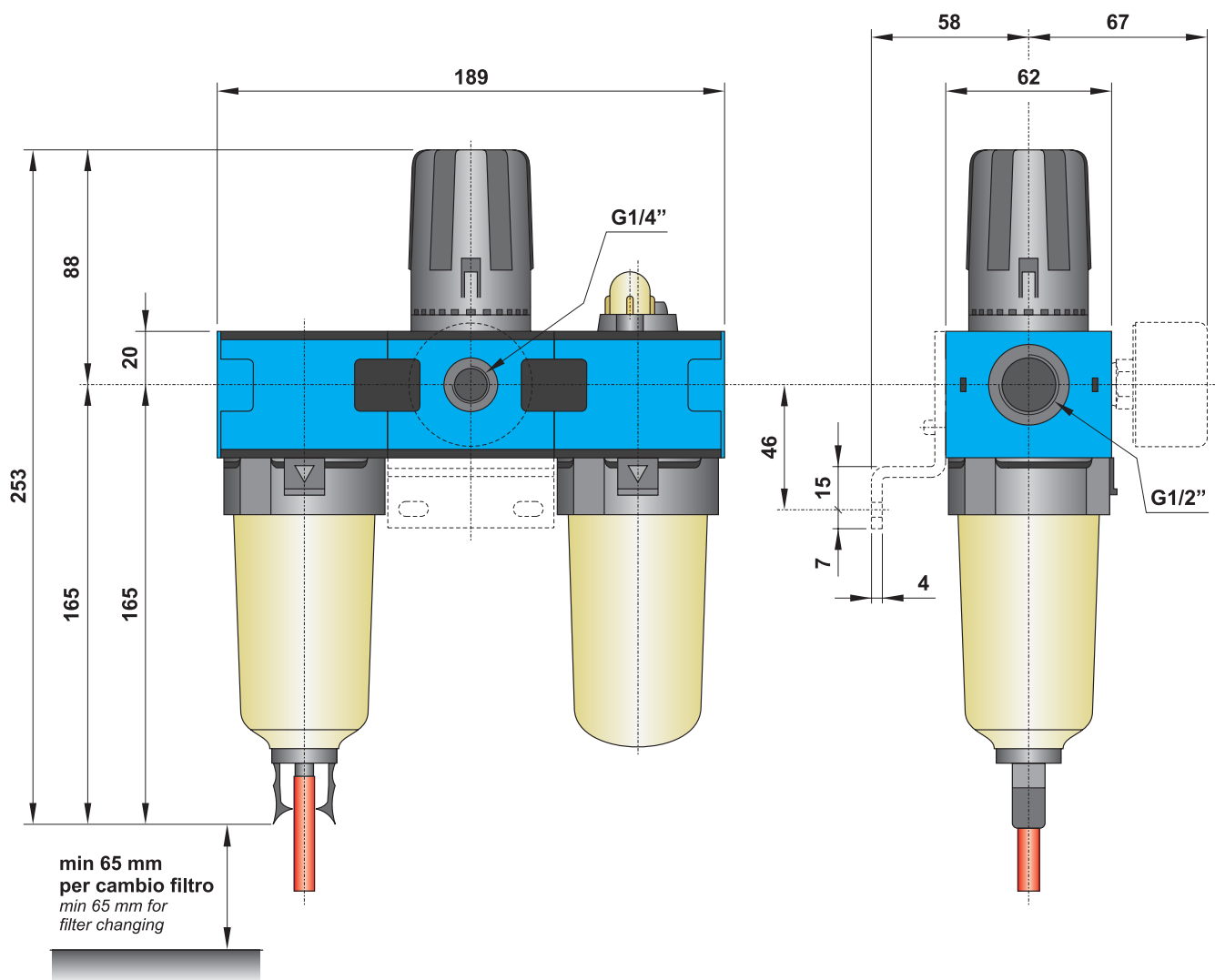
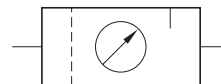

Materiali

Corpo: alluminio pressofuso

Guarnizioni: NBR

Parti interne: ottone e INOX

Parti esterne: polimeri rinforzati

Tazze: policarbonato rinforzato

Materials

Body: die-cast aluminium

Seals: NBR

Internal parts: brass and stainless steel

External parts: reinforced polymer

Bowls: reinforced polycarbonate

gruppo trattamento aria FRL G1"

G1" FRL air preparation unit



- Il gruppo comprende: filtro, regolatore di pressione e lubrificatore
The unit includes: filter, pressure regulator and oil mist lubricator
- Separazione condensa: 96%
Moisture separation: 96%
- Scarico semiautomatico della condensa; rifornimento olio manuale
Semi-automatic moisture exhaust; manual oil refilling
- Capacità delle tazze: 500 cm³ (condensa), 500 cm³ (olio)
Bowl capacity: 500 cm³ (moisture), 500 cm³ (oil)
- Installazione verticale; staffe di fissaggio a richiesta (cod. STF 6)
Vertical installation; brackets on request (code STF 6)
- Tazza metallica
Metal bowl



CODICE DI ORDINAZIONE ORDER CODE		FRL 6-10-30-S
Attacchi <i>Ports</i>		G1"
Temperatura di esercizio <i>Temperature range</i>		max +50°C
Peso <i>Weight</i>		5.7 kg
Pressione di alimentazione <i>Inlet pressure range</i>	$p_{1 \text{ min}}$ $p_{1 \text{ max}}$	0 bar; 0 MPa 10 bar; 1 MPa
Pressione di utilizzo <i>Outlet pressure range</i>	$p_{2 \text{ min}}$ $p_{2 \text{ max}}$	0.5 bar; 0.05 MPa 10 bar; 10 MPa
Differenza minima di pressione (Δp) <i>Minimum pressure difference (Δp)</i>	$p_1 - p_2$	0.2 bar; 0.02 MPa
Isteresi <i>Hysteresis</i>	$p_1 = 10 \text{ bar} / p_2 = 0 \text{ bar}$ $p_1 = 10 \text{ bar} / p_2 = 8 \text{ bar}$	0.6 0.3
Portata raccomandata <i>Recommended flow rate</i>	$p_2 = 6.3 \text{ bar a } 25 \text{ m/s}$ $p_2 = 6.3 \text{ bar at } 25 \text{ m/s}$	Q_n 5000 NI/min (max 9000 NI/min)
Elemento filtrante <i>Filter element</i>		30 μm

Caratteristiche di portata
Flow characteristics

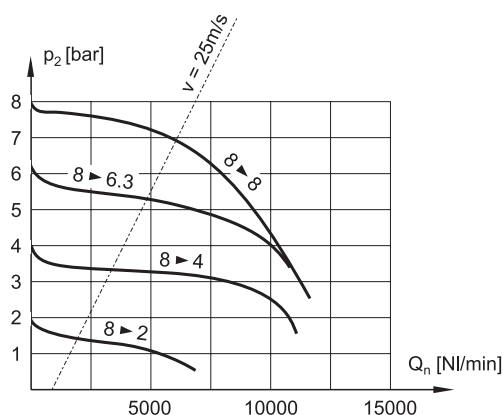

gruppo trattamento aria FRL G1"

G1" FRL air preparation unit



Le staffe di fissaggio e il manometro devono essere acquistati separatamente.
Mounting brackets and manometer are bought separately.

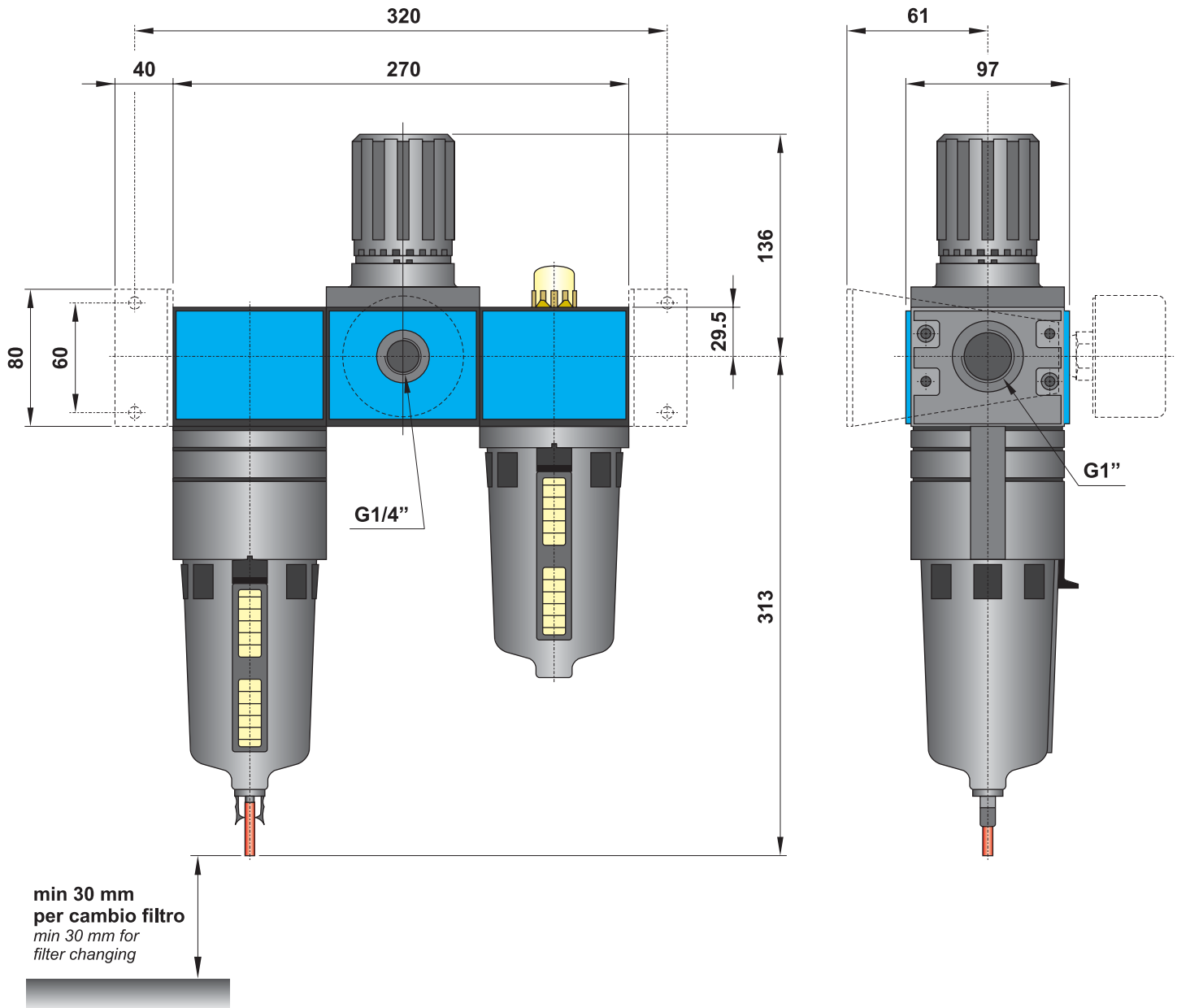
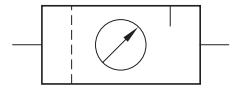

Materiali

Corpo: alluminio pressofuso

Guarnizioni: NBR

Parti interne: ottone e INOX

Parti esterne: polimeri rinforzati

Tazze: metalliche

Materials

Body: die-cast aluminium

Seals: NBR

Internal parts: brass and stainless steel

External parts: reinforced polymer

Bowls: metal

avviatore progressivo modulare G1/4"

modular slow-start valve G1/4"



Modalità di funzionamento

Questo tipo di avviatore progressivo è modulare e può essere installato in batteria con i gruppi trattamento aria serie G1/4".

(a) Dopo aver attivato l'avviatore eccitando l'elettropilota, viene fornita al circuito una pressione progressivamente crescente fino alla metà della pressione di rete. Il raggiungimento di questa soglia si effettua nel tempo determinato con la vite di regolazione **R**.

(b) Raggiunta tale pressione, l'avviatore progressivo passa ad alimentare il circuito con la pressione fornita dalla rete. Questa commutazione avviene in modo automatico senza intervento dell'operatore.

Togliendo il comando elettrico di attivazione, l'avviatore progressivo consente lo scarico del circuito senza dover togliere l'alimentazione di rete al punto 1.

Valve operation

This slow-start valve is modular and can be installed together with air preparation units, series G1/4".

(a) When the pilot solenoid valve is energised, a progressively increasing pressure is applied to the circuit over a period of time set by screw **(R)**.

(b) Once the half of the system pressure has been reached, the slow-start valve begins to automatically feed the circuit with the system pressure.

When the solenoid is de-energised the system pressure is exhausted without disconnecting system pressure at point 1.

CODICE DI ORDINAZIONE
ORDER CODE

AVP 2-00

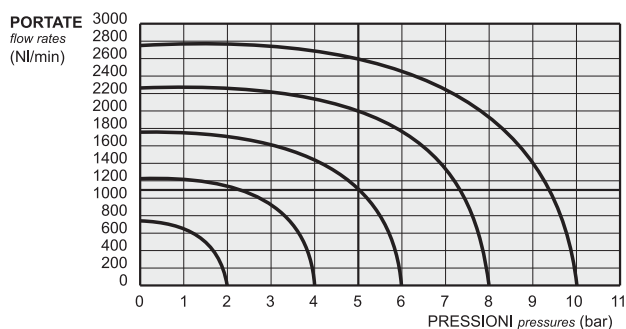

Attacchi <i>Ports</i>	G1/4"
Massima portata nella fase (a) <i>Maximum flow rate in the phase (a)</i>	300 NI/min
Portata nella fase (b) <i>Flow rate in the phase (b)</i>	vedi grafico <i>see graphic</i>
Pressione di esercizio <i>Working pressure</i>	2 ... 10 bar 0.2 ... 1 MPa
Temperatura di esercizio <i>Temperature range</i>	max +60°C
Fluido <i>Fluid</i>	Aria filtrata 50µ con o senza lubrificazione <i>50µ filtered, lubricated or non lubricated air</i>

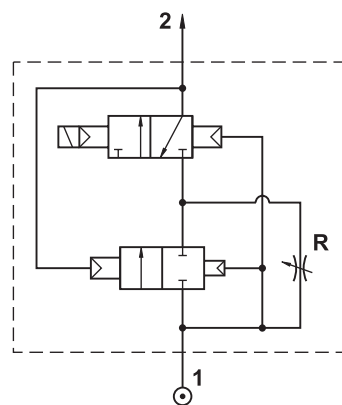

Materiali

Corpo: alluminio 11S

Molle: INOX

Guarnizioni: NBR

Spole: alluminio nichelato

Parti interne: ottone OT58

Materials

Body: aluminium 11S

Springs: stainless steel

Seals: NBR

Spools: nickel plated aluminium

Internal parts: brass OT58

avviatore progressivo modulare G1/4"

modular slow-start valve G1/4"



Il prodotto è venduto senza bobina, da acquistarsi separatamente (vedi pag. 242).
The product is sold without coil, which is bought separately (refer to page 242).

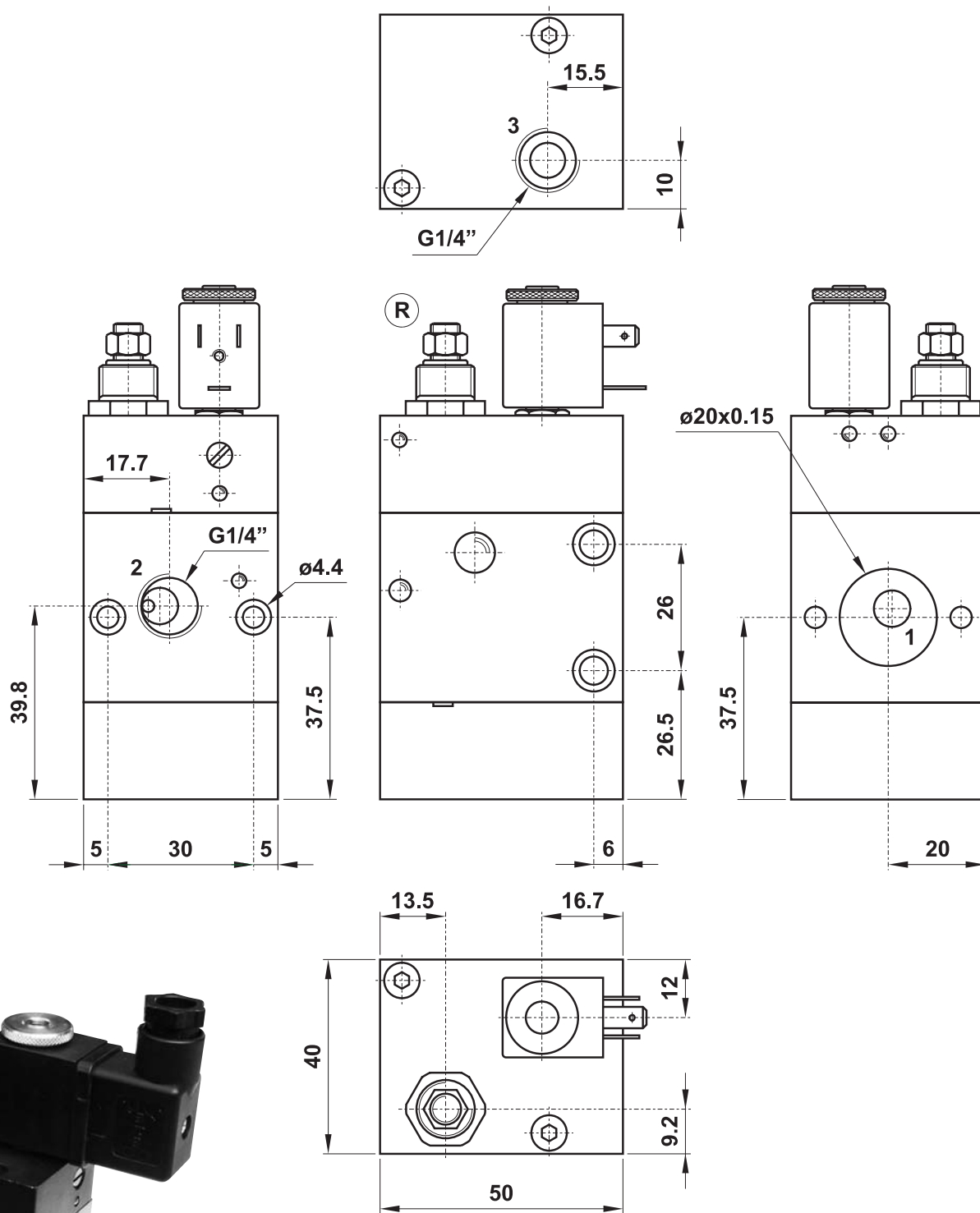

5

valvola di scarico rapido G3/8"

G3/8" quick exhaust valve



- Valvola 3/2 a comando elettrico o pneumatico
Pneumatically or solenoid actuated 3/2 valve
- Elevata portata in scarico
High exhaust flow rate
- Staffa di fissaggio a richiesta (cod. STF 3)
Mounting bracket on request (code STF 3)

Il prodotto è venduto senza bobina e senza staffa di fissaggio, da acquistarsi separatamente. La bobina deve essere della serie 30 mm.

The product is sold without coil and without mounting bracket, which are bought separately. The coil must be 30 mm.

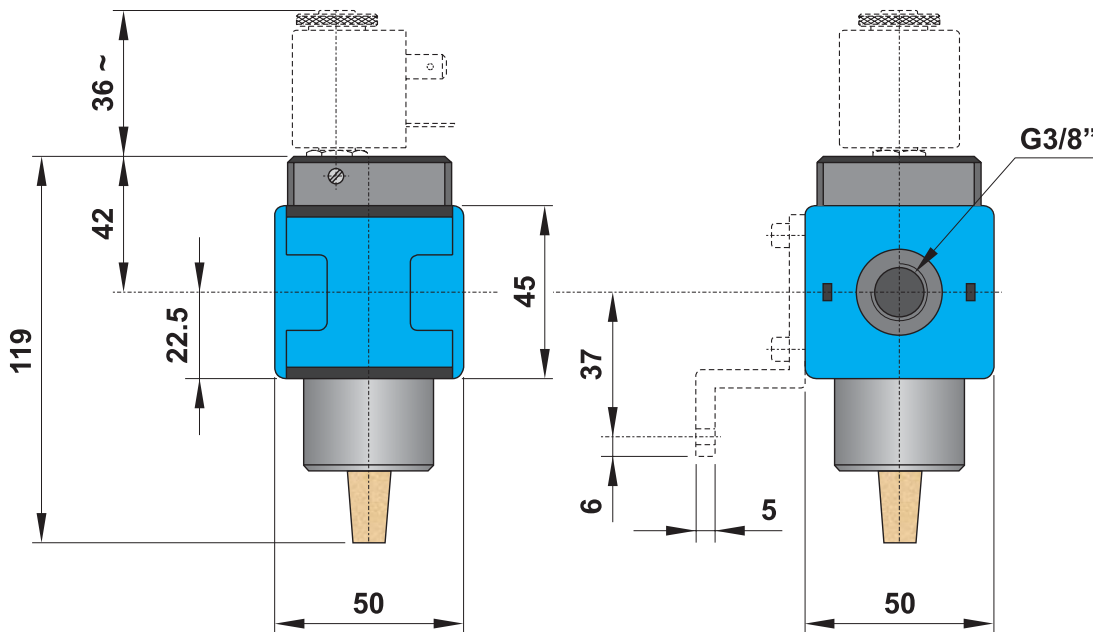

Bobine
Coils

modello model	tensione tension
00.258.0	24V DC
00.029.0	24V 50/60Hz
00.030.0	110V 50/60Hz
00.031.0	220V 50/60Hz

5

Materiali Corpo: alluminio pressofuso Guarnizioni: NBR Parti interne: ottone e INOX Parti esterne: polimeri rinforzati	Materials <i>Body: die-cast aluminium</i> <i>Seals: NBR</i> <i>Internal parts: brass and stainless steel</i> <i>External parts: reinforced polymer</i>		
		comando pneumatico <i>pneumatically piloted</i>	comando elettrico <i>solenoid actuated</i>
CODICE DI ORDINAZIONE <i>ORDER CODE</i>		SCR 3-P	SCR 3-E
Attacchi <i>Ports</i>		G3/8"	G3/8"
Temperatura di esercizio <i>Temperature range</i>		max +60°C	max +60°C
Peso <i>Weight</i>		0.5 kg	0.8 kg
Pressione di esercizio <i>Working pressure range</i>	p_{min} p_{max}	2 bar; 0.2 MPa 16 bar; 1.6 MPa	2 bar; 0.2 MPa 10 bar; 1 MPa
Portata raccomandata <i>Recommended flow rate</i>	$p = 6 \text{ bar a } 25 \text{ m/s}$ $p = 6 \text{ bar at } 25 \text{ m/s}$	Q_n	Q_n
Portata massima <i>Maximum flow rate</i>	$p = 6.3 \text{ bar; } \Delta p = 1 \text{ bar}$	Q_{max}	Q_{max}

avviatore progressivo G3/8"

G3/8" slow-start valve



Modalità di funzionamento

La valvola fornisce a un circuito pneumatico aria a pressione progressivamente crescente fino a raggiungere la metà della pressione di rete nel tempo impostato con la vite di regolazione integrata. Durante questa fase non devono essere attivi gli elementi del circuito che consumano aria. Raggiunta la soglia di commutazione, l'avviatore progressivo passa automaticamente a fornire la pressione di rete.

L'avviatore progressivo impedisce eventuali movimenti improvvisi dei dispositivi pneumatici montati nel circuito, che si potrebbero avere se venisse fornita immediatamente la pressione di rete.

Per il montaggio è disponibile l'apposita staffa (cod. STF 3).

Valve operation

The valve applies to a pneumatic circuit a progressively increasing pressure over a period of time set by the integrated screw. During this phase no air consumption is allowed in the circuit. After having reached the half of the system pressure, the slow-start valve begins to automatically feed the circuit with the system pressure.

The slow-start valve prevents from unexpected motions of the pneumatic devices in the circuit, which could happen by applying directly the system pressure.

On request the mounting bracket (code STF 3) is available.

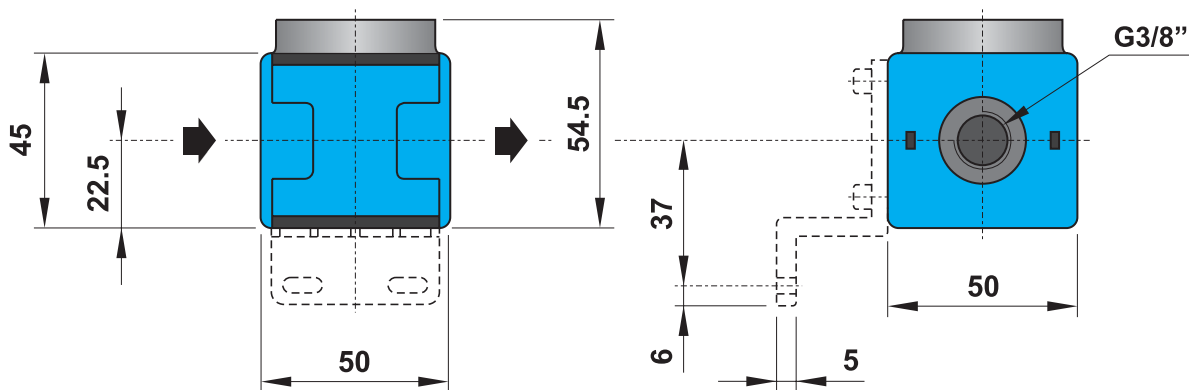
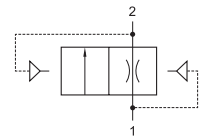

Materiali

Corpo: alluminio pressofuso

Guarnizioni: NBR

Parti interne: ottone e INOX

Parti esterne: polimeri rinforzati

Materials

Body: die-cast aluminium

Seals: NBR

Internal parts: brass and stainless steel

External parts: reinforced polymer

La staffa di fissaggio deve essere acquistata separatamente.

Mounting bracket is bought separately.

CODICE DI ORDINAZIONE ORDER CODE		AVP 3-00
Attacchi Ports		G3/8"
Temperatura di esercizio Temperature range		max +60°C
Peso Weight		0.35 kg
Pressione di esercizio Working pressure range	p_{min} p_{max}	2 bar; 0.2 MPa 16 bar; 1.6 MPa
Portata raccomandata Recommended flow rate	$p = 6.3 \text{ bar a } 25 \text{ m/s}$ $p = 6.3 \text{ bar at } 25 \text{ m/s}$	Q_n 850 NI/min
Portata massima Maximum flow rate		Q_{max} 1600 NI/min

valvola di scarico rapido G1/2"

G1/2" quick exhaust valve



- Valvola 3/2 a comando elettrico o pneumatico
Pneumatically or solenoid actuated 3/2 valve
- Da utilizzarsi da sola o in combinazione con l'avviatore progressivo
To be used standing-alone or with the slow-start valve
- Elevata portata in scarico
High exhaust flow rate
- Staffa di fissaggio a richiesta (cod. STF 4)
Mounting bracket on request (code STF 4)



		comando pneumatico <i>pneumatically piloted</i>	comando elettrico <i>solenoid actuated</i>
CODICE DI ORDINAZIONE <i>ORDER CODE</i>		SCR 4-P	SCR 4-E
Attacchi <i>Ports</i>		G1/2"	G1/2"
Temperatura di esercizio <i>Temperature range</i>		max +60°C	max +60°C
Peso <i>Weight</i>		0.7 kg	0.8 kg
Pressione di esercizio <i>Working pressure range</i>	p_{min} p_{max}	2 bar; 0.2 MPa 16 bar; 1.6 MPa	2 bar; 0.2 MPa 10 bar; 1 MPa
Portata raccomandata <i>Recommended flow rate</i>	$p = 6 \text{ bar a } 25 \text{ m/s}$ $p = 6 \text{ bar at } 25 \text{ m/s}$	Q_n	1900 NI/min
Portata massima <i>Maximum flow rate</i>	$p = 6.3 \text{ bar; } \Delta p = 1 \text{ bar}$	Q_{max}	2900 NI/min

Caratteristiche di portata
Flow characteristics

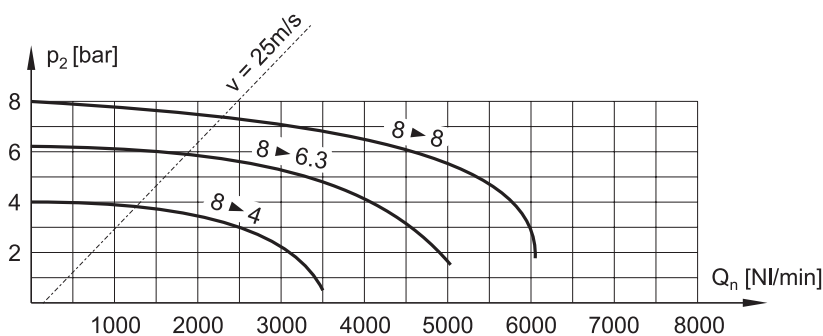

Bobine
Coils

modello <i>model</i>	tensione <i>tension</i>
00.258.0	24V DC
00.029.0	24V 50/60Hz
00.030.0	110V 50/60Hz
00.031.0	220V 50/60Hz

valvola di scarico rapido G1/2"

G1/2" quick exhaust valve



Il prodotto è venduto senza bobina e senza staffa di fissaggio, da acquistarsi separatamente.

La bobina deve essere della serie 30 mm.

The product is sold without coil and without mounting bracket, which are bought separately.

The coil must be 30 mm.

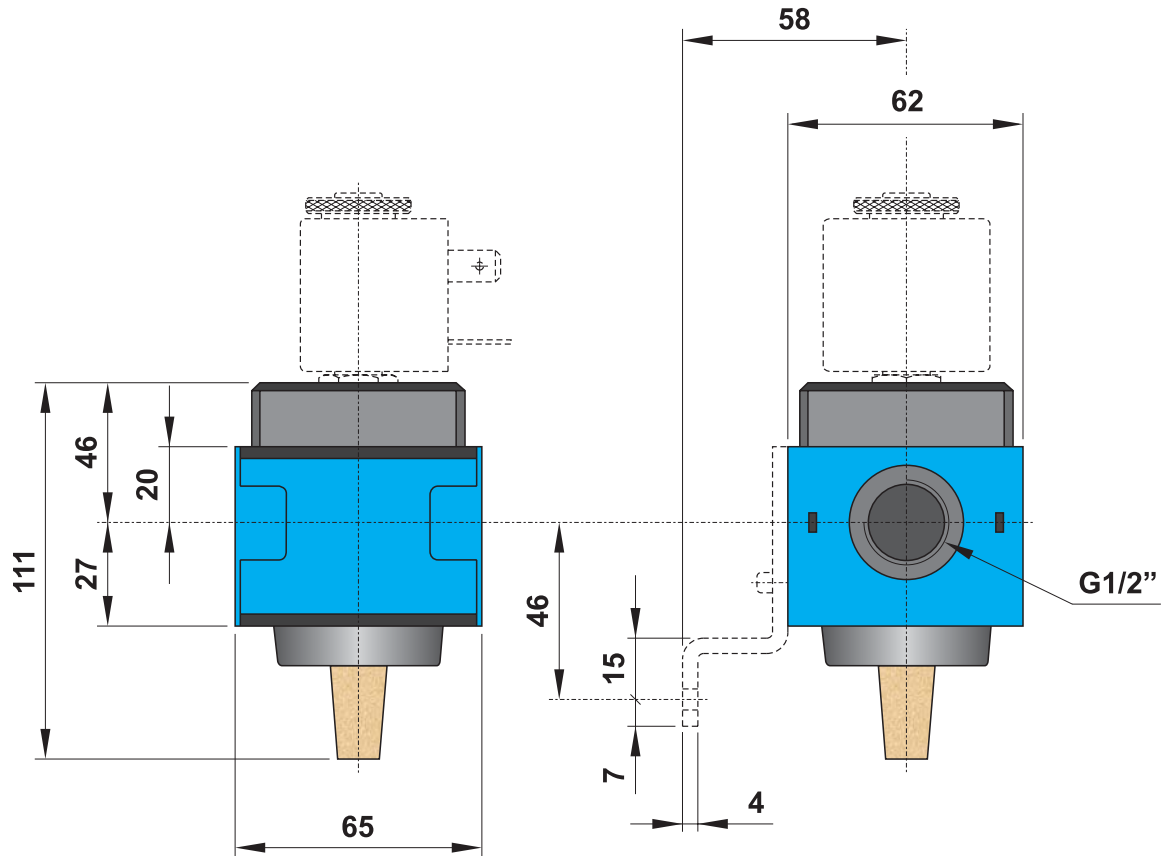

Materiali

Corpo: alluminio pressofuso

Guarnizioni: NBR

Parti interne: ottone e INOX

Parti esterne: polimeri rinforzati

Materials

Body: die-cast aluminium

Seals: NBR

Internal parts: brass and stainless steel

External parts: reinforced polymer

avviatore progressivo G1/2"

G1/2" slow-start valve



Modalità di funzionamento

La valvola fornisce a un circuito pneumatico aria a pressione progressivamente crescente fino a raggiungere la metà della pressione di rete nel tempo impostato con la vite di regolazione integrata. Durante questa fase non devono essere attivi gli elementi del circuito che consumano aria. Raggiunta la soglia di commutazione, l'avviatore progressivo passa automaticamente a fornire la pressione di rete.

L'avviatore progressivo impedisce eventuali movimenti improvvisi dei dispositivi pneumatici montati nel circuito, che si potrebbero avere se venisse fornita immediatamente la pressione di rete.

Per il montaggio è disponibile l'apposita staffa (cod. STF 4).

Valve operation

The valve applies to a pneumatic circuit a progressively increasing pressure over a period of time set by the integrated screw. During this phase no air consumption is allowed in the circuit. After having reached the half of the system pressure, the slow-start valve begins to automatically feed the circuit with the system pressure.

The slow-start valve prevents from unexpected motions of the pneumatic devices in the circuit, which could happen by applying directly the system pressure.

On request the mounting bracket (code STF 4) is available.

CODICE DI ORDINAZIONE ORDER CODE		AVP 4-00	
Attacchi Ports		G1/2"	
Temperatura di esercizio Temperature range		max +60°C	
Peso Weight		0.6 kg	
Pressione di esercizio Working pressure range		p_{\min} p_{\max}	2 bar; 0.2 MPa 16 bar; 1.6 MPa
Portata raccomandata Recommended flow rate	$p = 6 \text{ bar a } 25 \text{ m/s}$ $p = 6 \text{ bar at } 25 \text{ m/s}$	Q_n	1900 NI/min
Portata massima Maximum flow rate	$p = 6.3 \text{ bar; } \Delta p = 1 \text{ bar}$	Q_{\max}	3700 NI/min

Caratteristiche di portata
Flow characteristics

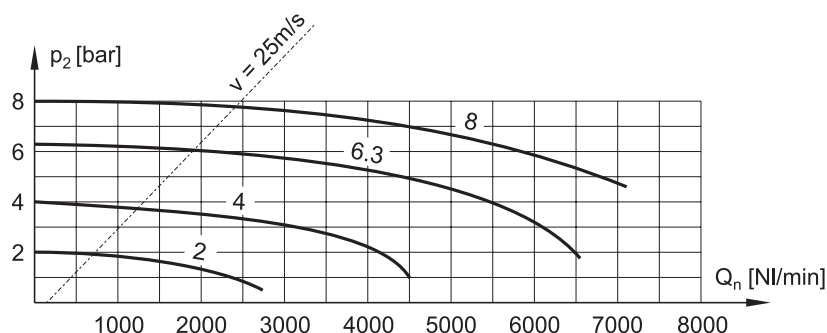

avviatore progressivo G1/2"

G1/2" slow-start valve



La staffa di fissaggio deve essere acquistata separatamente.
Mounting bracket is bought separately.

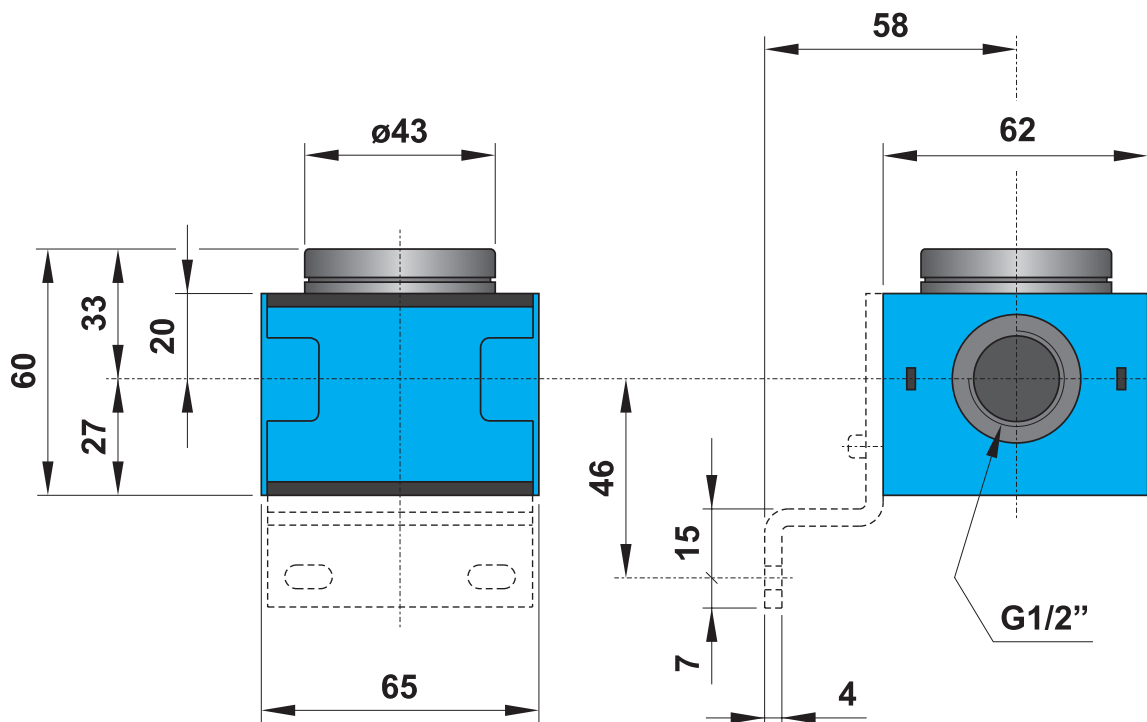
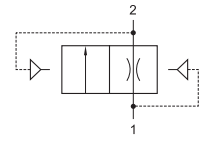

Materiali

Corpo: alluminio pressofuso

Guarnizioni: NBR

Parti interne: ottone e INOX

Parti esterne: polimeri rinforzati

Materials

Body: die-cast aluminium

Seals: NBR

Internal parts: brass and stainless steel

External parts: reinforced polymer

valvola di sezionamento circuito 3/2 G3/8"

3/2 G3/8" shut-off valve



- Elemento modulare ad alte prestazioni
High performance modular element
- Elevata portata in scarico
High exhaust flow rate
- Possibilità di chiusura a lucchetto
It can be secured with a padlock
- Installazione in qualsiasi posizione
Installation in any position

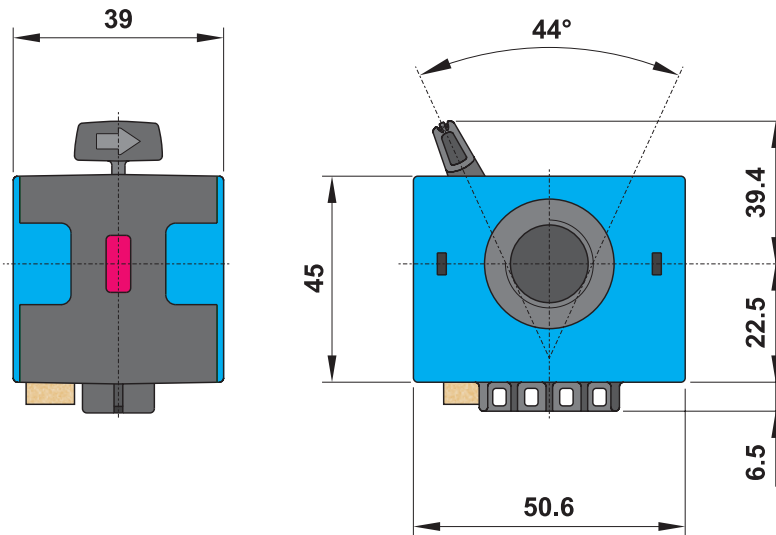
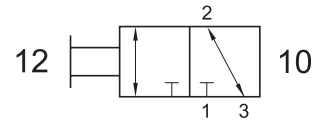

Materiali

Corpo: alluminio pressofuso

Parti interne: INOX

Parti esterne: polimeri rinforzati

Materials

Body: die-cast aluminium

Internal parts: stainless steel

External parts: reinforced polymer

CODICE DI ORDINAZIONE <i>ORDER CODE</i>		SR-M3
Attacchi <i>Ports</i>		G3/8"
Temperatura di esercizio <i>Temperature range</i>		max +60°C
Peso <i>Weight</i>		0.25 kg
Pressione di esercizio <i>Working pressure range</i>	p_{\min} p_{\max}	0 bar; 0 MPa 16 bar; 1.6 MPa
Portata raccomandata <i>Recommended flow rate</i>	$p = 6.3 \text{ bar a } 25 \text{ m/s}$ $p = 6.3 \text{ bar at } 25 \text{ m/s}$	Q_n 850 NI/min
Portata massima <i>Maximum flow rate</i>		Q_{\max} 5300 NI/min

valvola di sezionamento circuito 3/2 G1/2"

3/2 G1/2" shut-off valve



- Elemento modulare ad alte prestazioni
High performance modular element
- Elevata portata in scarico
High exhaust flow rate
- Possibilità di chiusura a lucchetto
It can be secured with a padlock
- Installazione in qualsiasi posizione
Installation in any position

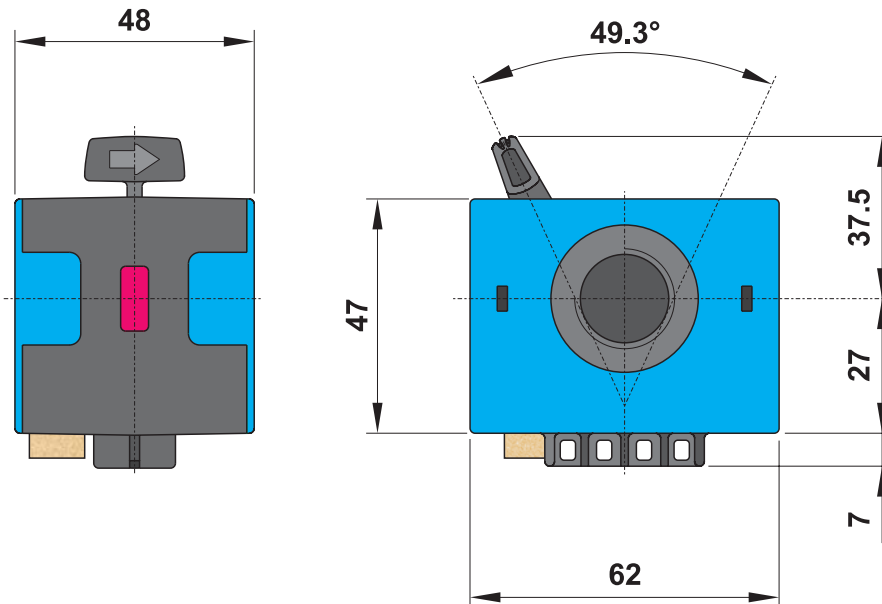
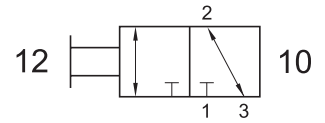

Materiali

Corpo: alluminio pressofuso

Parti interne: INOX

Parti esterne: polimeri rinforzati

Materials

Body: die-cast aluminium

Internal parts: stainless steel

External parts: reinforced polymer

CODICE DI ORDINAZIONE <i>ORDER CODE</i>		SR-M4
Attacchi <i>Ports</i>		G1/2"
Temperatura di esercizio <i>Temperature range</i>		max +60°C
Peso <i>Weight</i>		0.4 kg
Pressione di esercizio <i>Working pressure range</i>	p_{min} p_{max}	0 bar; 0 MPa 16 bar; 1.6 MPa
Portata raccomandata <i>Recommended flow rate</i>	$p = 6.3 \text{ bar a } 25 \text{ m/s}$ $p = 6.3 \text{ bar at } 25 \text{ m/s}$	Q_n 1900 NI/min
Portata massima <i>Maximum flow rate</i>		Q_{max} 7500 NI/min

valvola di sezionamento circuito 3/2 G1"

3/2 G1" shut-off valve



- Elemento modulare ad alte prestazioni
High performance modular element
- Elevata portata in scarico
High exhaust flow rate
- Installazione in qualsiasi posizione
Installation in any position

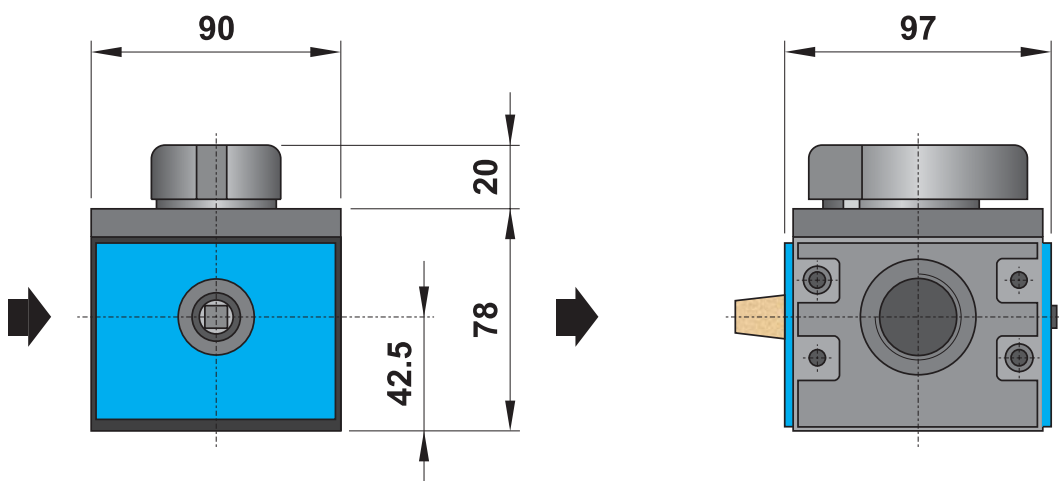
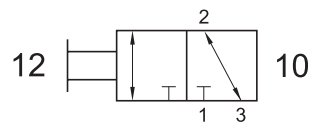

Materiali

Corpo: alluminio pressofuso

Parti interne: INOX

Parti esterne: polimeri rinforzati

Materials

Body: die-cast aluminium

Internal parts: stainless steel

External parts: reinforced polymer

CODICE DI ORDINAZIONE <i>ORDER CODE</i>		SR-M6
Attacchi <i>Ports</i>		G1"
Temperatura di esercizio <i>Temperature range</i>		max +60°C
Peso <i>Weight</i>		1.8 kg
Pressione di esercizio <i>Working pressure range</i>	p_{min} p_{max}	0 bar; 0 MPa 16 bar; 1.6 MPa
Portata raccomandata <i>Recommended flow rate</i>	$p = 6.3 \text{ bar a } 25 \text{ m/s}$ $p = 6.3 \text{ bar at } 25 \text{ m/s}$	Q_n 5000 NI/min
Portata massima <i>Maximum flow rate</i>		Q_{max} > 20000 NI/min

regolatore proporzionale elettronico G3/8"

electronically controlled proportional pressure regulator G3/8"



- Valvola di regolazione a pistone
Piston-type pressure regulating valve
- Controllo elettronico remoto
Remote electronic control
- Pressione minima di controllo e di funzionamento: 0 bar
Control and operating pressure: min. 0 bar
- Struttura modulare, compatibile con gli altri elementi della serie G3/8"
Modular design, direct coupling with G3/8" units
- Non consuma aria
No air consumption
- Installazione verticale; staffa di fissaggio a richiesta (cod. STF 3)
Vertical installation; bracket on request (code STF 3)

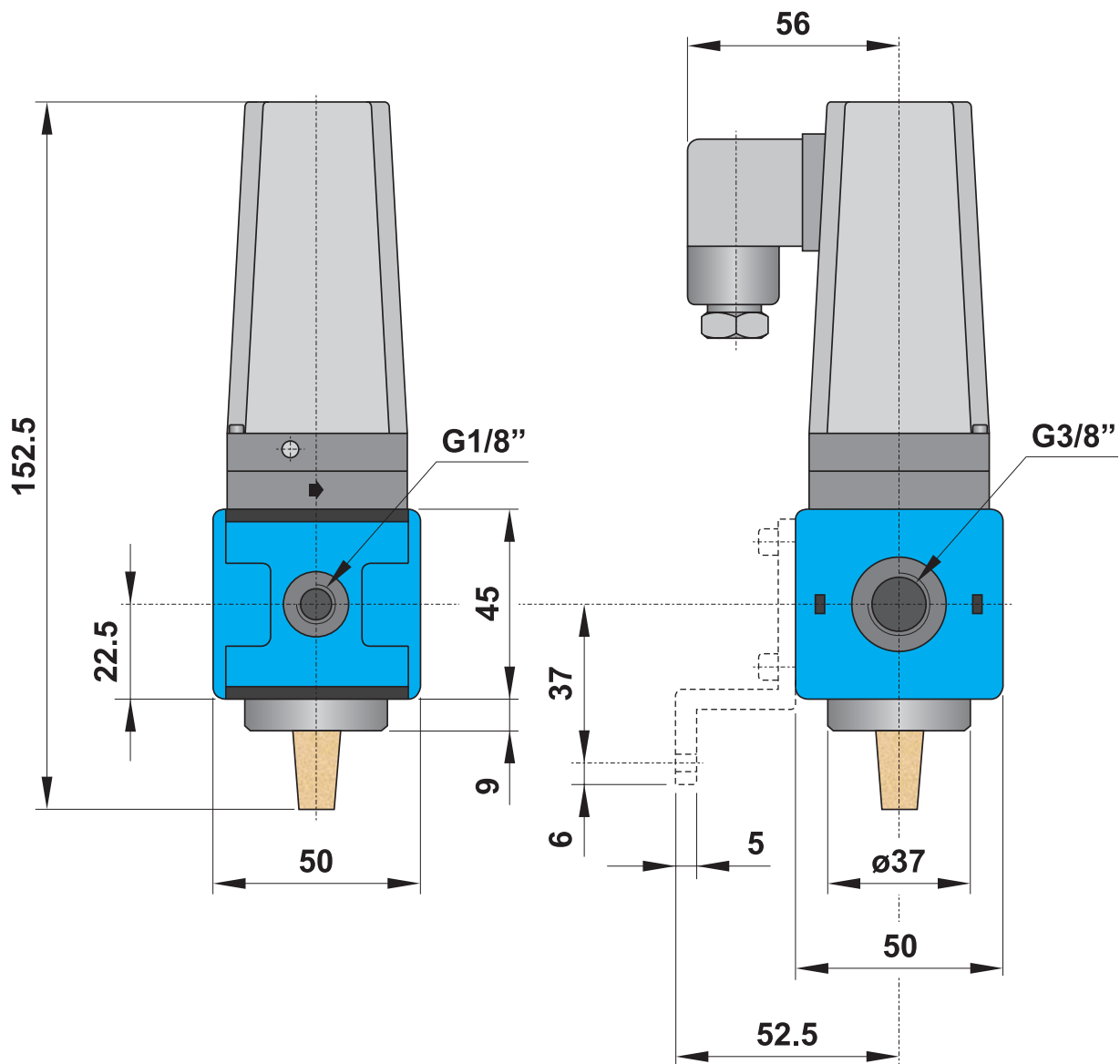

regolatore proporzionale elettronico G3/8"

electronically controlled proportional pressure regulator G3/8"



CODICE DI ORDINAZIONE ORDER CODE		RPE 3 V NC	RPE 3 V NA	RPE 3 A NC
		normalmente chiuso <i>normally closed</i>	normalmente aperto <i>normally open</i>	normalmente chiuso <i>normally closed</i>
Attacchi <i>Ports</i>		G3/8"	G3/8"	G3/8"
Temperatura di esercizio <i>Temperature range</i>		max +50°C	max +50°C	max +50°C
Fluido <i>Fluid</i>		Aria filtrata 50µ con o senza lubrificazione <i>50µ filtered, lubricated or non lubricated air</i>		
Peso <i>Weight</i>		0.6 kg	0.6 kg	0.6 kg
Caratteristiche pneumatiche - Pneumatic characteristics				
Pressione di alimentazione ($p_1 \geq p_2 + 0.1 \cdot p_2$) <i>Inlet pressure range</i>	$p_{1 \min}$ $p_{1 \max}$	0 bar; 0 MPa 10 bar; 1 MPa	0 bar; 0 MPa 10 bar; 1 MPa	0 bar; 0 MPa 10 bar; 1 MPa
Pressione di utilizzo <i>Outlet pressure range</i>	$p_{2 \min}$ $p_{2 \max}$	0 bar; 0 MPa 10 bar; 1 MPa	0 bar; 0 MPa 10 bar; 1 MPa	0 bar; 0 MPa 10 bar; 1 MPa
Portata nominale <i>Nominal flow rate</i>	$p_1 = 10 \text{ bar}; p_2 = 6.3 \text{ bar}$ Q_n	2500 NI/min	2500 NI/min	2500 NI/min
Portata raccomandata <i>Recommended flow rate</i>	$p_2 = 6.3 \text{ bar a } 25 \text{ m/s}$ $p_2 = 6.3 \text{ bar at } 25 \text{ m/s}$ Q_n	850 NI/min	850 NI/min	850 NI/min
Isteresi <i>Hysteresis</i>	% $p_{2 \max}$	< 1	< 1	< 1
Ripetibilità <i>Repeatability</i>	% $p_{2 \max}$	< 0.5	< 0.5	< 0.5
Sensibilità <i>Sensitivity</i>	% $p_{2 \max}$	< 0.5	< 0.5	< 0.5
Linearità <i>Linearity</i>	% $p_{2 \max}$	< 1	< 1	< 1
Caratteristiche elettriche - Electrical characteristics				
Voltaggio nominale <i>Nominal voltage</i>	U_N	24V DC ± 10%	24V DC ± 10%	24V DC ± 10%
Oscillazione residua <i>Residual ripple</i>		10%	10%	10%
Consumo di corrente <i>Power consumption</i>		0.15 A	0.15 A	0.15 A
Tensione del segnale di regolazione <i>Tension of set value input</i>	U_w	0-10 V	0-10 V	0-10 V
Intensità del segnale di regolazione <i>Current intensity of set value input</i>	I_w	0-20 mA	0-20 mA	4-20 mA
Resistenza in ingresso <i>Input resistance</i>	R_E	200 kΩ	200 kΩ	200 kΩ
Tensione del segnale di rilevazione della pressione in uscita <i>Tension of actual value output</i>	U_x	0-10 V	0-10 V	0-10 V
Intensità del segnale di rilevazione della pressione in uscita <i>Current intensity of actual value output</i>	$I_{x \max}$	20 mA	20 mA	20 mA
Protezione elettrica secondo DIN 40050, EN 60529 <i>Electrical protection according to DIN 40050, EN 60529</i>		IP 65	IP 65	IP 65

L'impostazione della regolazione per il modello **RPE 3 V NC** e **RPE 3 V NA** è basata sulla tensione del segnale di ingresso (da 0 a 10 V, un Volt per ogni bar). Per il modello **RPE 3 A NC** la regolazione è basata sull'intensità del segnale di ingresso (da 4 a 20 mA).

The setting of the input value, for the model **RPE 3 V NC** and **RPE 3 V NA**, is based on the voltage of the input signal (from 0 to 10 V, one Volt for each bar).

For the model **RPE 3 A NC** the setting is based on the current intensity of the input signal (from 4 to 20 mA).

regolatore proporzionale elettronico G3/8"

electronically controlled proportional pressure regulator G3/8"



Schema pneumatico
Pneumatic diagram

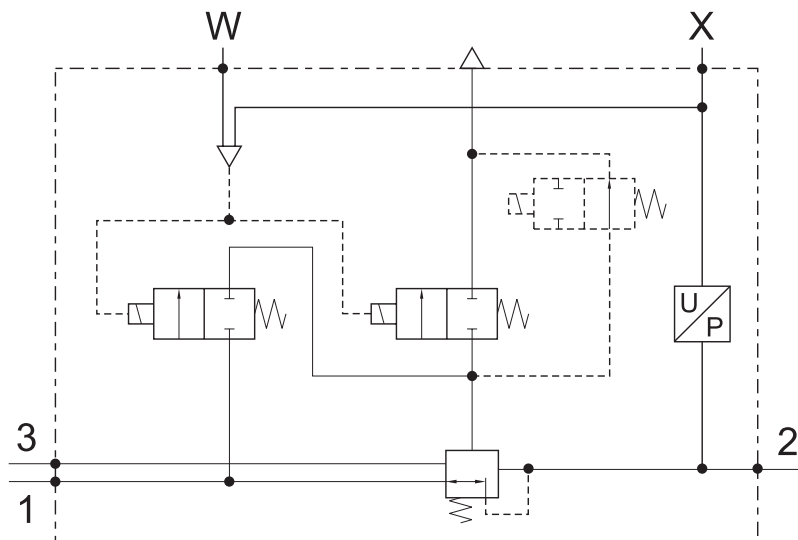

Caratteristiche di portata
Flow characteristics

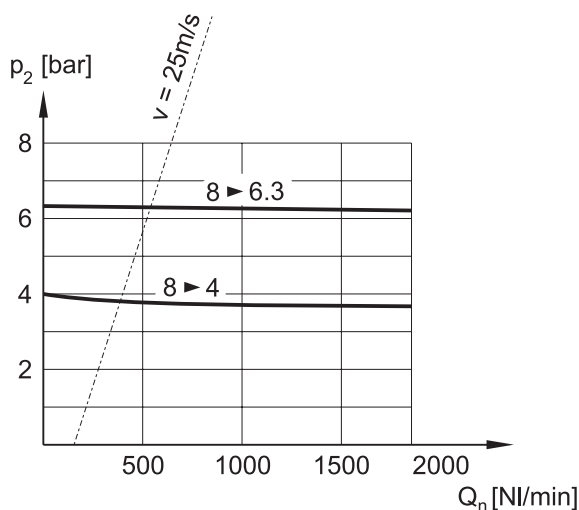

Pressione in uscita in funzione della tensione del segnale in ingresso
Output pressure as function of input voltage

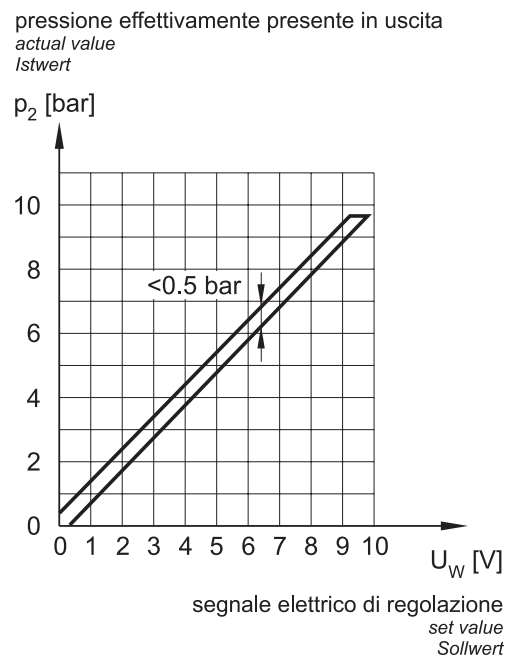

La staffa di fissaggio (cod. STF 3), il kit di assemblaggio (cod. KIT 3-00) e il manometro devono essere acquistati separatamente.

Per lo schema di collegamento e la spiegazione dei termini tecnici vedi le pagine 449-450-451.

Mounting bracket (code STF 3), coupling kit (code KIT 3-00) and manometer are bought separately.

For the connection diagram and the explanation of the technical terms see pages 449-450-451.

regolatore proporzionale elettronico G1/2"

electronically controlled proportional pressure regulator G1/2"



- Valvola di regolazione a pistone
Piston-type pressure regulating valve
- Controllo elettronico remoto
Remote electronic control
- Pressione minima di controllo e di funzionamento: 0 bar
Control and operating pressure: min. 0 bar
- Struttura modulare, compatibile con gli altri elementi della serie G1/2"
Modular design, direct coupling with G1/2" units
- Non consuma aria
No air consumption
- Installazione verticale; staffa di fissaggio a richiesta (cod. STF 4)
Vertical installation; bracket on request (code STF 4)

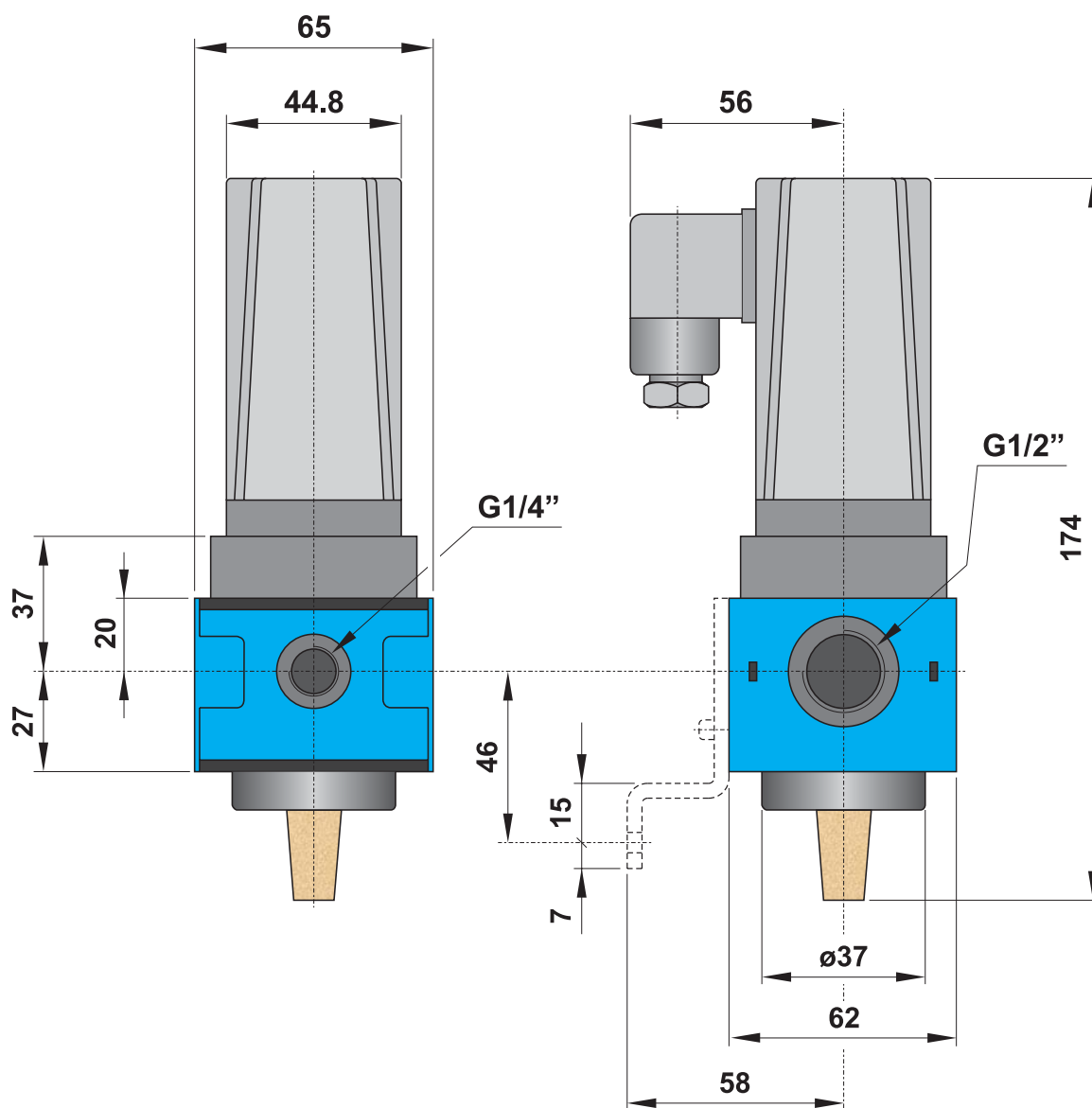

5

regolatore proporzionale elettronico G1/2"

electronically controlled proportional pressure regulator G1/2"



CODICE DI ORDINAZIONE ORDER CODE		RPE 4 V NC	RPE 4 V NA	RPE 4 A NC
		normalmente chiuso <i>normally closed</i>	normalmente aperto <i>normally open</i>	normalmente chiuso <i>normally closed</i>
Attacchi <i>Ports</i>		G1/2"	G1/2"	G1/2"
Temperatura di esercizio <i>Temperature range</i>		max +50°C	max +50°C	max +50°C
Fluido <i>Fluid</i>		Aria filtrata 50µ con o senza lubrificazione <i>50µ filtered, lubricated or non lubricated air</i>		
Peso <i>Weight</i>		0.95 kg	0.95 kg	0.95 kg
Caratteristiche pneumatiche - Pneumatic characteristics				
Pressione di alimentazione ($p_1 \geq p_2 + 0.1 \cdot p_2$) <i>Inlet pressure range</i>	$p_{1 \min}$ $p_{1 \max}$	0 bar; 0 MPa 16 bar; 1.6 MPa	0 bar; 0 MPa 16 bar; 1.6 MPa	0 bar; 0 MPa 16 bar; 1.6 MPa
Pressione di utilizzo <i>Outlet pressure range</i>	$p_{2 \min}$ $p_{2 \max}$	0 bar; 0 MPa 10 bar; 1 MPa	0 bar; 0 MPa 10 bar; 1 MPa	0 bar; 0 MPa 10 bar; 1 MPa
Portata nominale <i>Nominal flow rate</i>	$p_1 = 10 \text{ bar}; p_2 = 6.3 \text{ bar}$ Q_n	6000 NI/min	6000 NI/min	6000 NI/min
Portata raccomandata <i>Recommended flow rate</i>	$p_2 = 6.3 \text{ bar a } 25 \text{ m/s}$ $p_2 = 6.3 \text{ bar at } 25 \text{ m/s}$ Q_n	1900 NI/min	1900 NI/min	1900 NI/min
Isteresi <i>Hysteresis</i>	% $p_{2 \max}$	< 1	< 1	< 1
Ripetibilità <i>Repeatability</i>	% $p_{2 \max}$	< 0.5	< 0.5	< 0.5
Sensibilità <i>Sensitivity</i>	% $p_{2 \max}$	< 0.5	< 0.5	< 0.5
Linearità <i>Linearity</i>	% $p_{2 \max}$	< 1	< 1	< 1
Caratteristiche elettriche - Electrical characteristics				
Voltaggio nominale <i>Nominal voltage</i>	U_N	24V DC ± 10%	24V DC ± 10%	24V DC ± 10%
Oscillazione residua <i>Residual ripple</i>		10%	10%	10%
Consumo di corrente <i>Power consumption</i>		0.15 A	0.15 A	0.15 A
Tensione del segnale di regolazione <i>Tension of set value input</i>	U_w	0-10 V	0-10 V	0-10 V
Intensità del segnale di regolazione <i>Current intensity of set value input</i>	I_w	0-20 mA	0-20 mA	4-20 mA
Resistenza in ingresso <i>Input resistance</i>	R_E	200 kΩ	200 kΩ	200 kΩ
Tensione del segnale di rilevazione della pressione in uscita <i>Tension of actual value output</i>	U_x	0-10 V	0-10 V	0-10 V
Intensità del segnale di rilevazione della pressione in uscita <i>Current intensity of actual value output</i>	$I_{x \max}$	20 mA	20 mA	20 mA
Protezione elettrica secondo DIN 40050, EN 60529 <i>Electrical protection according to DIN 40050, EN 60529</i>		IP 65	IP 65	IP 65

L'impostazione della regolazione per il modello **RPE 4 V NC** e **RPE 4 V NA** è basata sulla tensione del segnale di ingresso (da 0 a 10 V, un Volt per ogni bar). Per il modello **RPE 4 A NC** la regolazione è basata sull'intensità del segnale di ingresso (da 4 a 20 mA).

The setting of the input value, for the model **RPE 4 V NC** and **RPE 4 V NA**, is based on the voltage of the input signal (from 0 to 10 V, one Volt for each bar).

For the model **RPE 4 A NC** the setting is based on the current intensity of the input signal (from 4 to 20 mA).

regolatore proporzionale elettronico G1/2"

electronically controlled proportional pressure regulator G1/2"



Schema pneumatico
Pneumatic diagram

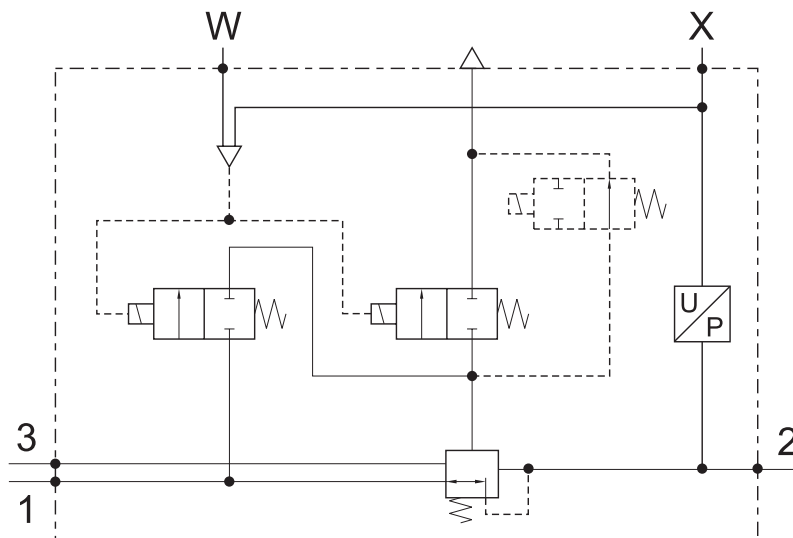

Caratteristiche di portata
Flow characteristics

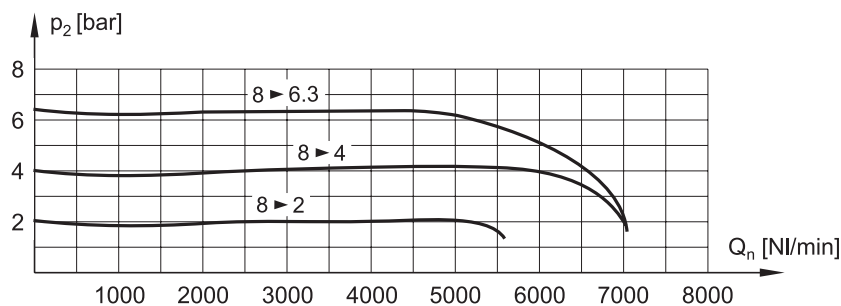

Pressione in uscita in funzione della tensione del segnale in ingresso
Output pressure as function of input voltage

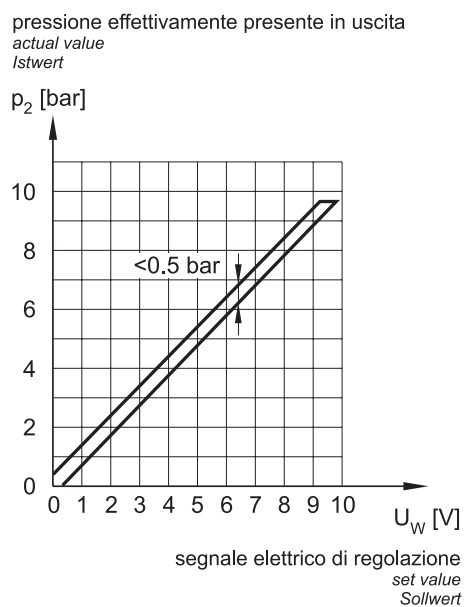

La staffa di fissaggio (cod. STF 4), il kit di assemblaggio (cod. KIT 4-00) e il manometro devono essere acquistati separatamente.

Per lo schema di collegamento e la spiegazione dei termini tecnici vedi le pagine 449-450-451.

Mounting bracket (code STF 4), coupling kit (code KIT 4-00) and manometer are bought separately.

For the connection diagram and the explanation of the technical terms see pages 449-450-451.

regolatore proporzionale elettronico

electronically controlled proportional pressure regulator



Schema di collegamento

Connection diagram

Anschlussschema

Shema priklopa

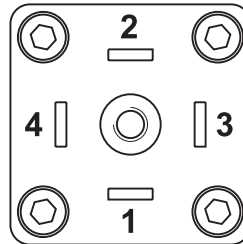

Punto 1:

Alimentazione (polo positivo) +24V DC $\pm 10\%$ 0.15 A
Oscillazione residua ammessa fino a 10%

Punto 2:

Alimentazione 0V
Potenziale di riferimento per l'impostazione del valore di regolazione (punto 3) e per la misurazione del valore di pressione effettivamente presente in uscita (punto 4).

Punto 3: Ingresso del segnale di regolazione.

Per la regolazione si utilizza la tensione (da 0 a 10V) o l'intensità di corrente (da 4 a 20 mA).

Punto 4: Rilevamento della pressione effettivamente presente in uscita. Uscita analogica variabile da 0 a 10V. La massima intensità di corrente possibile è 20mA. La tensione viene misurata in riferimento al potenziale presente al punto 2.

Klemme 1:

Stromversorgung Pluspol +24V DC $\pm 10\%$ 0.15A
Restwelligkeit 10%

Klemme 2:

Stromversorgung 0V
Bezugs- und Massepotential für Soll- und Istwert.

Klemme 3:

Sollwerteingang
An diesem Eingang liegt die positive Sollwertspannung von 0-10V bzw. der Strom 4-20 mA.

Klemme 4:

Analoger Istwertausgang 0-10V bei Geräten mit 10 bar Druckausgang.
Dieser Ausgang ist max. 20mA belastbar, die Signalspannung wird gegen Bezugspotential (Klemme 2) gemessen.

Pin 1: Power supply +24V DC $\pm 10\%$ 0.15A, residual ripple 10%

Pin 2: Power supply 0V, reference potential for set and actual value.

Pin 3: Set value input. Voltage 0-10V or current intensity 4-20mA

Pin 4: Analog actual value output. Voltage from 0 to 10V. The voltage is measured with reference to the potential at pin 2. This output has a max. capacity of 20 mA.

Pin 1: Napajanje +24V DC $\pm 10\%$ 0.15A, valovitost do 10%

Pin 2: Napajanje 0V, referenčna vrednost za nastavljeni in dejansko veličino.

Pin 3: Nastavitveni vhod. Regulirna veličina: napetost 0-10V ali tok 4-20 mA.

Pin 4: Analogen izhod proporcionalen dejanski vrednosti tlaka, napetost 0-10V. Napetost glede na referenčno vrednost na pinu 2. Dopuszna obremenitev izhoda 20 mA.

PLC connesso a più potenziometri

PLC in connection with several potentiometers

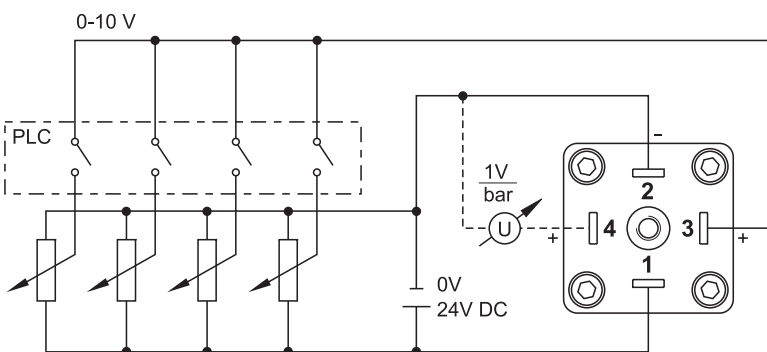

La resistenza totale dell'insieme dei potenziometri deve essere almeno 500 Ω

The total resistance of the potentiometers group should not be less than 500 Ω

Collegamento con un singolo potenziometro

Connection with a single potentiometer

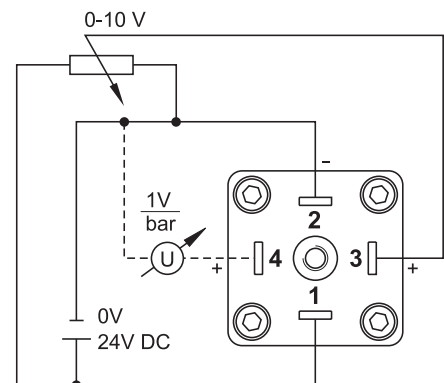

La resistenza del potenziometro deve essere tra 500 Ω e 100 k Ω

The resistance of the potentiometer should range between 500 Ω and 100 k Ω



Sensibilità

La minima variazione del valore di regolazione che causa una effettiva variazione della pressione in uscita è denominata "sensibilità" e si esprime in percentuale rispetto al valore massimo di pressione consentito dal dispositivo di regolazione. Nel caso del nostro regolatore di pressione proporzionale, il valore di sensibilità è inferiore allo 0.5%. Ciò significa che la regolazione è molto precisa.

Linearità

Esprimendo la pressione in uscita in funzione del valore di regolazione impostato, si dovrebbe poter ottenere una funzione lineare che consenta di predire quale sarà il valore in uscita in riferimento a un dato valore impostato. Esiste però una differenza tra il valore teoricamente previsto e il valore effettivamente presente in uscita, ed essa si può calcolare sulla base della massima deviazione rispetto al valore teorico corrispondente alla massima pressione consentita dal dispositivo di regolazione. La linearità si esprime in percentuale rispetto a questa massima pressione.

Isteresi

L'isteresi è causata dall'attrito e da una temporanea deformazione delle parti interne di natura elastica soggette a pressione. Durante il funzionamento si possono pertanto notare differenti pressioni in uscita in riferimento a un medesimo valore di regolazione. Questi diversi valori dipendono anche dal senso della regolazione, che può andare dal basso verso l'alto o dall'alto verso il basso. Il valore di isteresi del nostro regolatore di pressione è inferiore a 0.1 bar.

Ripetibilità

Impostando ripetutamente e in tempi distinti un medesimo valore di regolazione, i diversi valori di pressione effettivamente ottenuti in uscita sono pressoché identici e differiscono meno tra di loro che rispetto al valore teorico impostato. Una isteresi minore consente pertanto una ripetibilità migliore.

Ansprechempfindlichkeit

Die kleinste Sollwertdifferenz, die zu einer Änderung des Ausgangsdruckes führt, wird als Ansprechempfindlichkeit bezeichnet. In Prozentsatz vom maximalen Ausgangsdruck angegeben, beträgt dieser Wert nur 0.5%. Das ermöglicht eine sehr feinfühligkeit Einstellbarkeit des Ausgangsdruckes.

Linearität

Wird der Ausgangsdruck in Abhängigkeit vom Sollwert dargestellt, sollte sich eine möglichst gerade (lineare) Kennlinie ergeben, so dass möglichst exakt vorhergesagt werden kann, welcher Druck bei der jeweiligen Vorgabe zu erwarten ist. Die Abweichung errechnet sich aus der maximalen Differenz zur idealen Kennlinie, bezogen auf den höchstmöglichen Ausgangsdruck.

Hysterese

Die Hysterese wird auch Umkehrspanne genannt und entsteht durch Reibung sowie kurzfristige Verformung elastischer Bauteile. Für den Betrieb ergeben sich dadurch unterschiedliche Ausgangsdrücke bei gleicher Sollwert-Vorgabe, je nachdem, ob der vorhergegangene Wert größer oder kleiner war. Unser elektronisch gesteuertes Druckregelventil hat eine Abweichung kleiner als 0.1 bar.

Wiederholgenauigkeit

Regelungstechnische Komponenten sind in der Wiederholung eines einmal eingestellten Wertes genauer als beim Anfahren absoluter Werte. Darüber hinaus wird die Wiederholgenauigkeit durch eine möglichst kleine Hysterese günstig beeinflusst.

5



Sensitivity

The smallest change of set output pressure which leads to a change in actual output pressure is named "sensitivity" and it is expressed as percentage of the maximum output pressure possible for the device. The sensitivity of our pressure regulator is below 0.5%, which allows output pressure to be set very precisely.

Linearity

The ideal graphic curve which shows the output pressure in relation with the electronic input signal would be a straight (linear) line. This line would allow to predict which output pressure can be expected when a certain input voltage is applied. The deviation from the ideal value can be calculated on the basis of the difference between the ideal and the actual output value at the highest pressure allowed by the device, and it is expressed in percentage of this maximum output pressure.

Hysteresis

The same set output pressure generates slightly different actual output pressures, depending on whether the previous setting was higher or lower. This difference, known as hysteresis, is caused by friction and temporary deformation of elastic components. The hysteresis of our pressure regulator is below 0.1 bar.

Repeatability

Control components, for a given set value, usually produce repeated actual values which differ less from each other than from the absolute set value. Repeatability is improved if hysteresis is minimized.

Občutljivost

Najmanjša sprememba nastavljenega izhodnega pritiska, ki povzroči dejansko spremembo pritiska na izhodu naprave, se imenuje občutljivost in se izraža kot odstotek največjega možnega pritiska na izhodu naprave. Občutljivost našega tlačnega regulatorja je manjša od 0.5%, kar omogoča zelo precizno nastavitvev izhodnega pritiska.

Linearnost

Idealna krivulja, ki predstavlja odvisnost izhodnega pritiska od električnega vhodnega signala, je premica. S tako krivuljo bi lahko enostavno predvideli, kakšen bo pritisk na izhodu ob določeni električni napetosti na vhodu. Odstopanje od te idealne krivulje je moč izračunati iz razlike med idealno krivuljo in dejansko vrednostjo pritiska na izhodu, ko ta doseže največjo možno vrednost; odmik izražamo kot odstotek maksimalnega možnega pritiska na izhodu naprave.

Histereza

Določena vrednost vhodnega signala povzroči spremembo izhodnega pritiska, ki pa ni vedno enaka in je odvisna od tega, ali je bila prejšnja nastavljena vrednost višja ali nižja. To minimalno razliko, znano tudi kot histerezo, povzroča trenje in začasne deformacije prožnih komponent. Histereza našega tlačnega regulatorja znaša manj kot 0.1 bar.

Ponovljivost

Krmilne naprave se na neko nastavljeno vrednost vhoda navadno odzovejo z enakimi dejanskimi vrednostmi na izhodu, ki se ena od druge manj razlikujejo, kot se vsaka posamezna razlikuje od absolutne nastavljene vrednosti. Ponovljivost se izboljša z zmanjšanjem histereze.

PRESA D'ARIA

porting block

Può essere utilizzata per prelevare aria non lubrificata e/o non regolata.

It can be used to provide unlubricated and/or unregulated air.

G1/4"

CODICE DI ORDINAZIONE
ORDER CODE

PAI 2-00

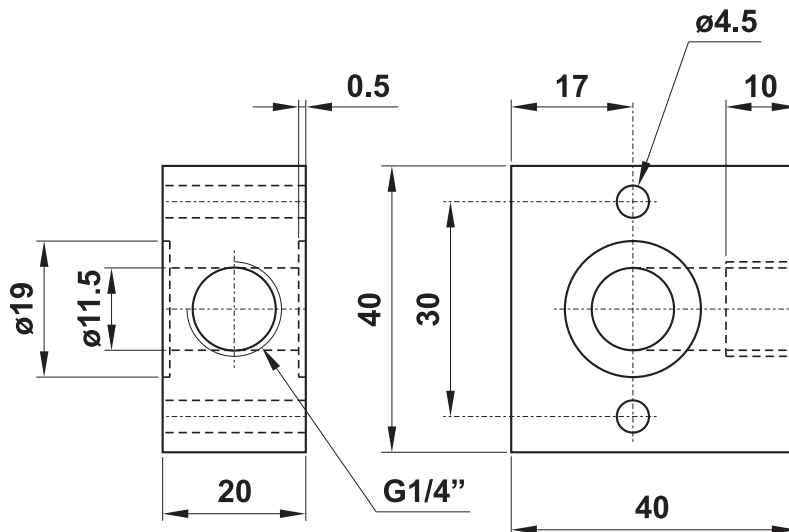
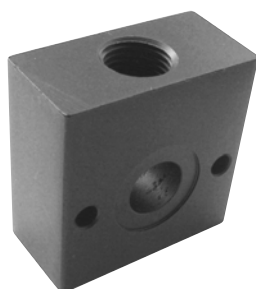

Materiale: alluminio

Material: aluminium

Ogni pezzo è venduto in kit con i particolari necessari al suo assemblaggio

Each element is sold in kit with all necessary pieces for installation

G3/8"

CODICE DI ORDINAZIONE
ORDER CODE

PAI 3-00

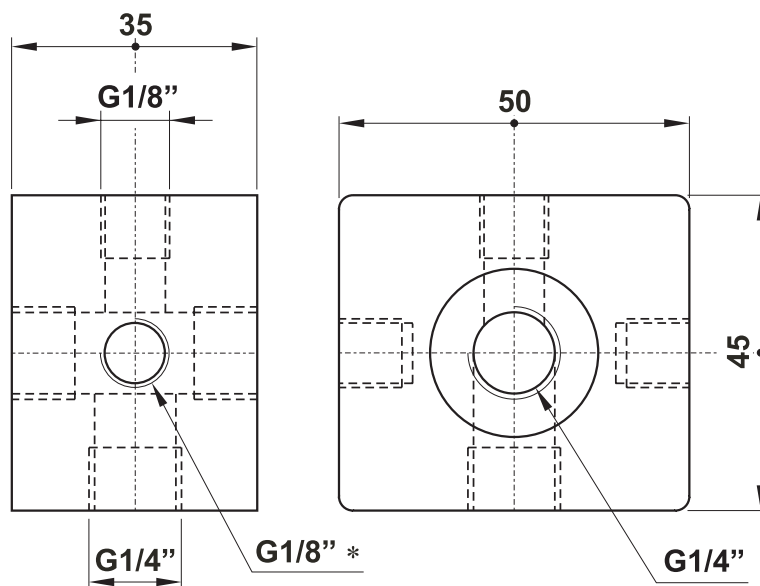

Materiale: zamak

Material: zamak

* : filetto G1/8" (prof. 10 mm circa) da ambo le parti.

In caso di necessità l'utilizzatore può forare il fondo per avere una presa d'aria aggiuntiva (foro $\varnothing 4$).

* : G1/8" thread on both sides (depth about 10 mm) ready for through-drilling hole $\varnothing 4$.

PROTEZIONE PER TAZZA

bowl protection

G1/4"

PLASTICA

CODICE DI ORDINAZIONE

ORDER CODE

PR 2-00

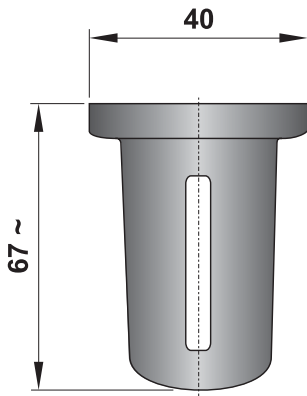

G3/8"

METALLO

CODICE DI ORDINAZIONE

ORDER CODE

PR 3-00

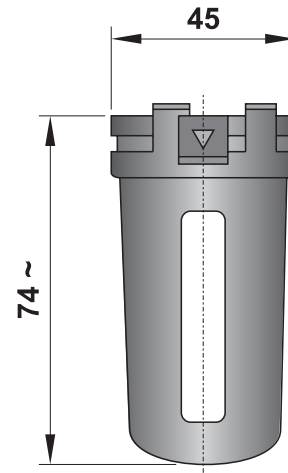

G1/2"

METALLO

CODICE DI ORDINAZIONE

ORDER CODE

PR 4-00

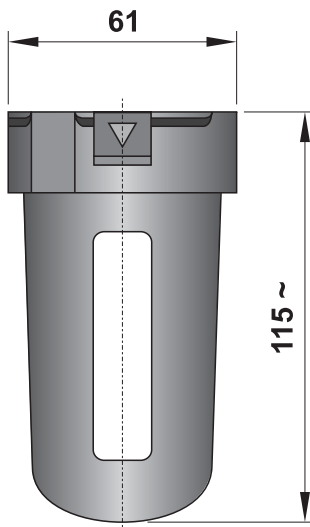

5

KIT MONTAGGIO

coupling kit

G1/4"

CODICE DI ORDINAZIONE
ORDER CODE

KIT 2-00

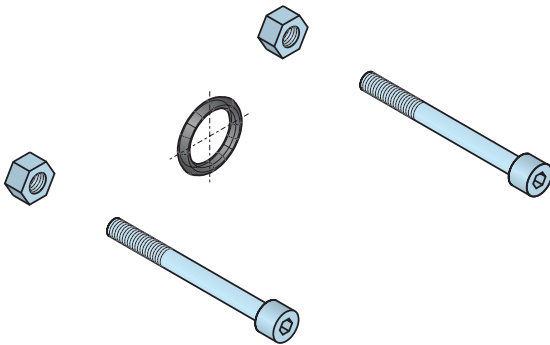

G3/8"

CODICE DI ORDINAZIONE
ORDER CODE

KIT 3-00

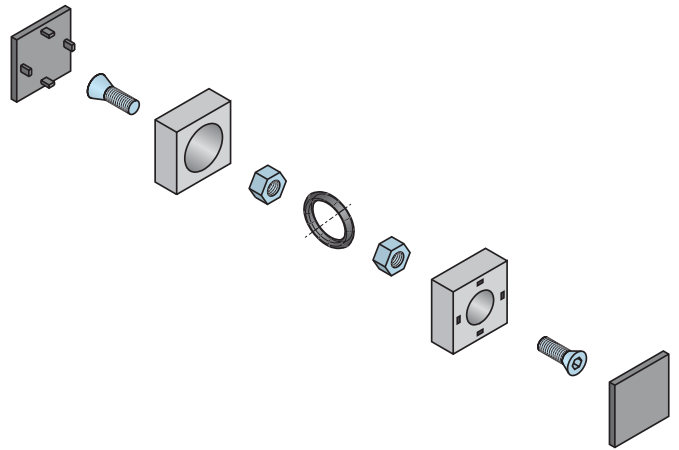

G1/2"

CODICE DI ORDINAZIONE
ORDER CODE

KIT 4-00

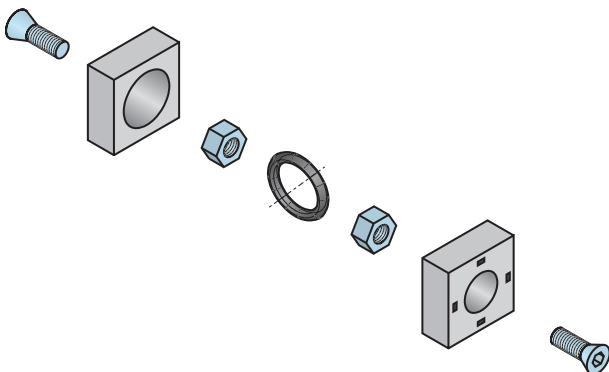

G1"

CODICE DI ORDINAZIONE
ORDER CODE

KIT 6-00

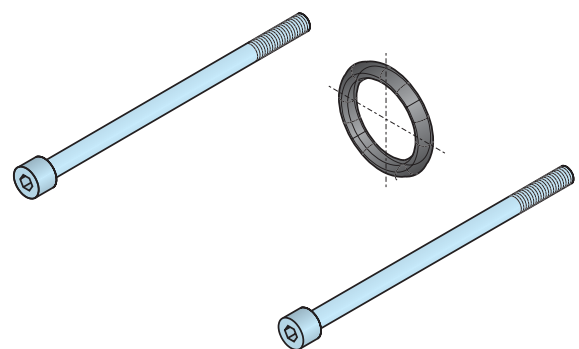

G1"
NUOVO

CODICE DI ORDINAZIONE
ORDER CODE

KIT 6N-00

5

SCARICO AUTOMATICO CONDENZA

automatic moisture exhaust

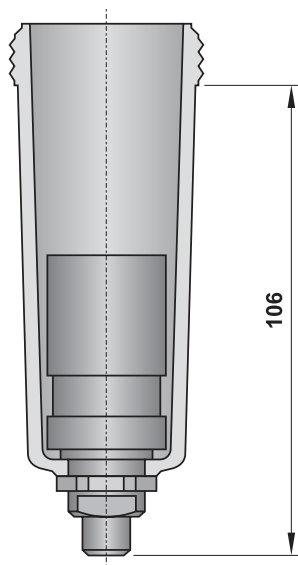

G3/8"

CODICE DI ORDINAZIONE
ORDER CODE

AKS 3

Per l'installazione sostituire la tazza normale con questa tazza dotata di scarico automatico.
This bowl with automatic exhaust replaces the normal filter bowl.

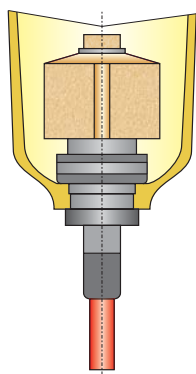

G1/2"





G1"

CODICE DI ORDINAZIONE
ORDER CODE

AKS 4-6

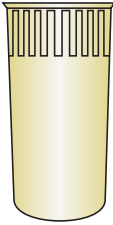
Per l'installazione montare questo elemento all'interno della tazza togliendo il dispositivo per lo scarico semiautomatico.
Lo stesso elemento si utilizza sia per i filtri da G1/2" sia per quelli da G1".
This element replaces the semi-automatic exhaust device located in a normal filter bowl.
The same element is used for G1/2" and G1" filters.

5

descrizione <i>description</i>		dimensione <i>size</i>	codice di ordinazione <i>order code</i>
	TAZZA PER LUBRIFICATORE <i>bowl for lubricator</i>	G1/4"	16.065.0
		G3/8"	16.067.0
		G1/2"	16.069.0
		G1"	16.009.2
	TAZZA PER FILTRO <i>bowl for filter</i>	G1/4"	16.064.0
		G3/8"	16.066.0
		G1/2"	16.068.0
		G1"	16.008.2
	MEMBRANA PER REGOLATORE DI PRESSIONE <i>diaphragm for pressure regulator</i>	G3/8"-G1/2"	16.098.0
		G1"	16.099.0
	ELEMENTO FILTRANTE <i>filter element</i>	25 µm	G1/4" 16.061.0
		5 µm	G1/4" 16.031.0
		30 µm	G3/8" 16.062.0
		5 µm	G3/8" 16.032.0
		30 µm	G1/2" 16.063.0
		5 µm	G1/2" 16.033.0
		30 µm	G1" 16.107.0 <i>per filtro [for filter]</i>
		30 µm	G1" 16.108.0 <i>per filtroregolatore [for filter-regulator]</i>
		5 µm	G1" 16.078.0 <i>per filtro [for filter]</i>
		5 µm	G1" 16.084.0 <i>per filtroregolatore [for filter-regulator]</i>
	CUPOLA VISIVA PER LUBRIFICATORE <i>oil view element for lubricator</i>	G1/4"	16.104.0
		G3/8"-G1/2"	16.105.0
		G1"	16.106.0

STAFFE DI FISSAGGIO

mounting brackets

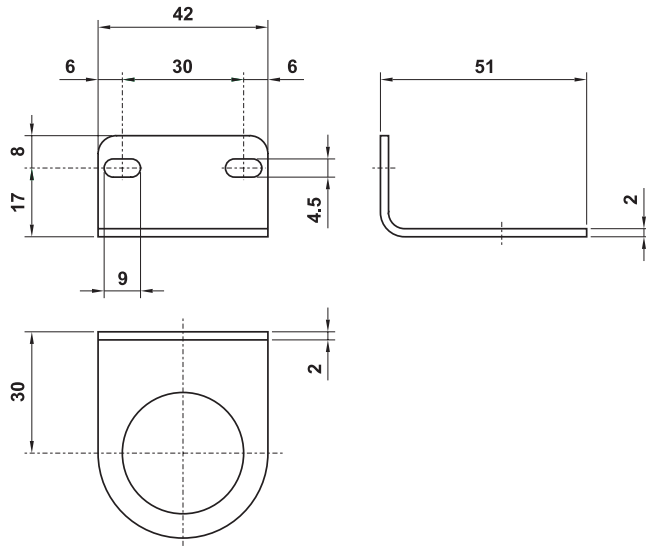

G1/4"

CODICE DI ORDINAZIONE
ORDER CODE

STF 2

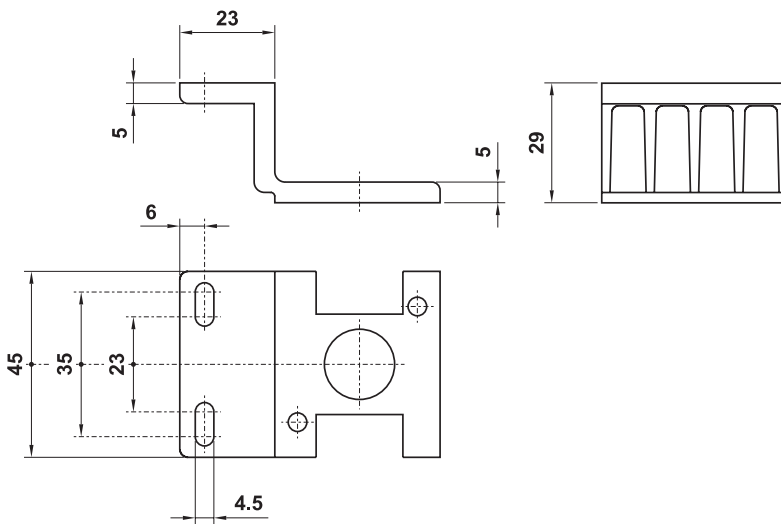

G3/8"

CODICE DI ORDINAZIONE
ORDER CODE

STF 3

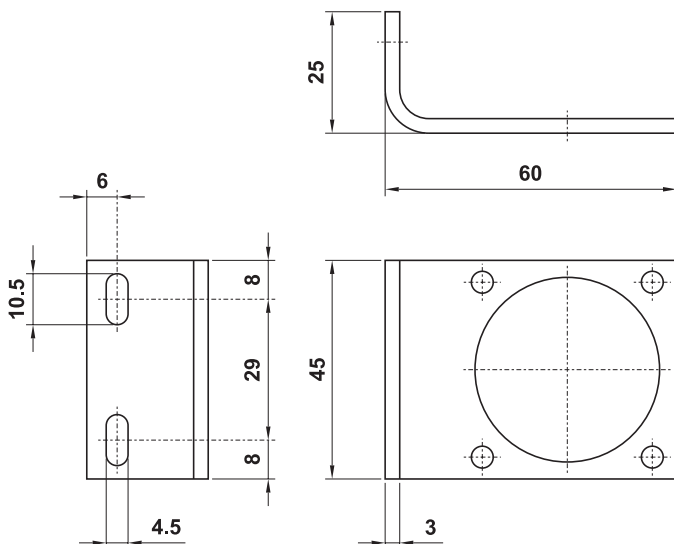

G3/8"

CODICE DI ORDINAZIONE
ORDER CODE

STF 3A

5

STAFFE DI FISSAGGIO

mounting brackets

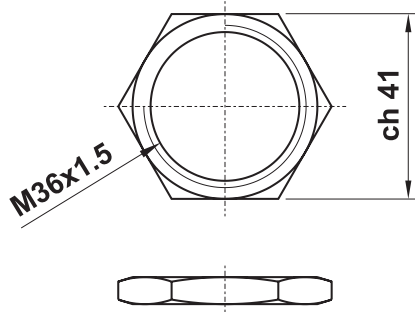

G3/8"

CODICE DI ORDINAZIONE
ORDER CODE

STF 3B

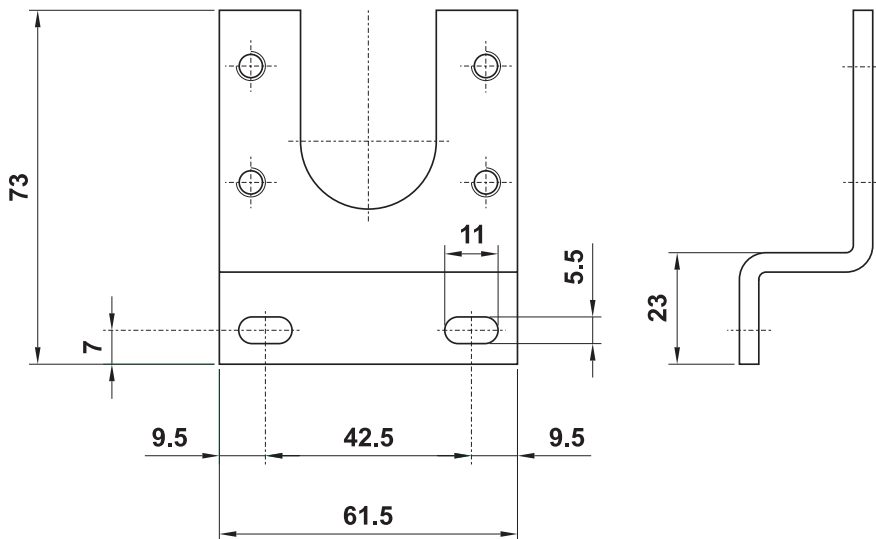

G1/2"

CODICE DI ORDINAZIONE
ORDER CODE

STF 4

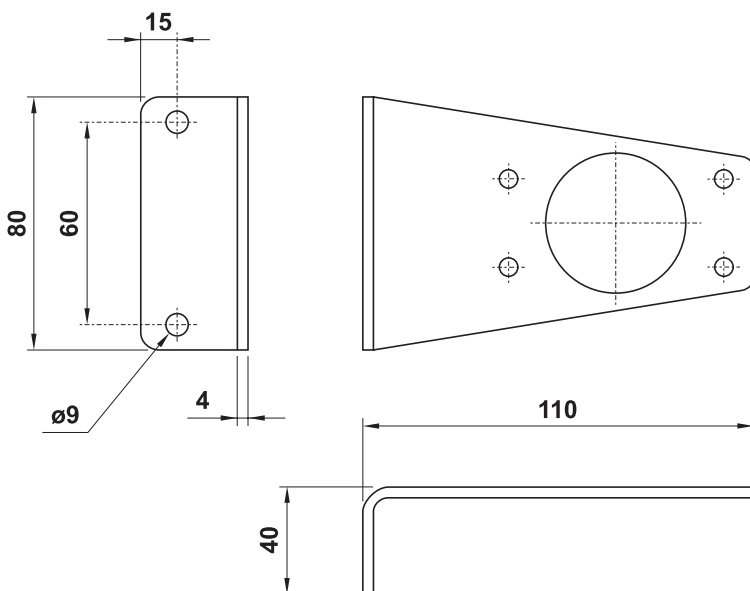

G1"

CODICE DI ORDINAZIONE
ORDER CODE

STF 6

La sigla si riferisce a una coppia di staffe
The part number is referred to a couple of brackets

piastrina di fissaggio a parete per filtri e lubrificatori G1/4"

adaptor for side mounting - filters and lubricators G1/4"

- Utilizzabile per il fissaggio a parete di **filtro e/o lubrificatore**
*It can be used to install **filter** and/or **lubricator***
- Si utilizza in posizione intermedia per il fissaggio di **FIL + LUB**
*To be used in intermediate position to install **FIL + LUB***
- Si utilizza come terminale per il fissaggio di **FIL o LUB**
*To be used as header to install **FIL** or **LUB***
- Materiale: alluminio anodizzato
Material: aluminium (anodize treatment)

CODICE DI ORDINAZIONE
ORDER CODE

16.004.2

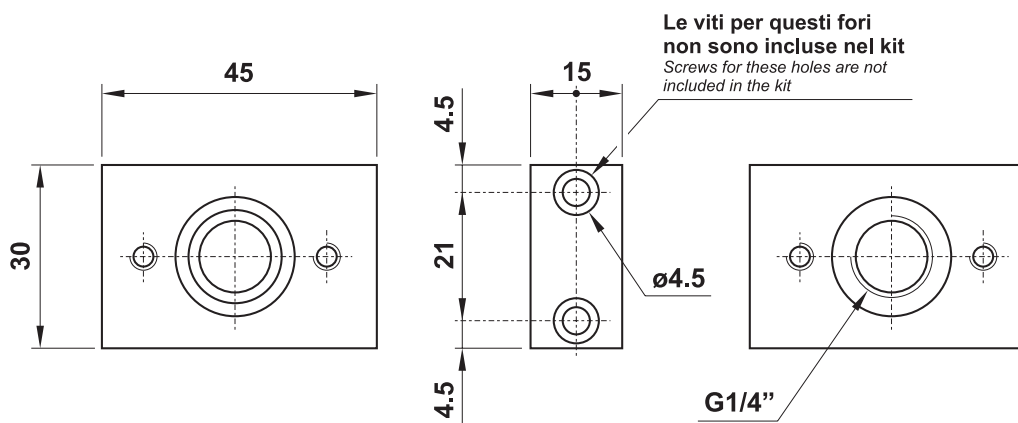

Ogni pezzo è venduto in kit con i particolari necessari al suo assemblaggio
Each element is sold in kit with all necessary pieces for installation

Montaggio in posizione intermedia
Installation in intermediate position

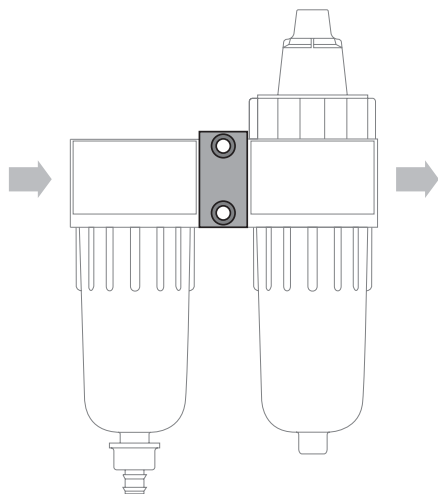

Montaggio come terminale
Installation as header

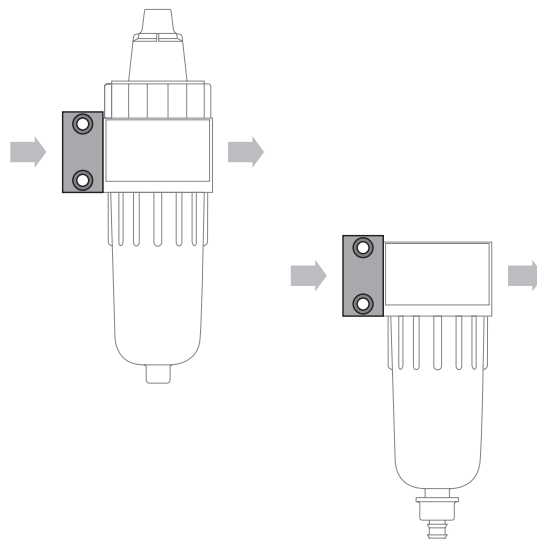

piastrina di fissaggio a parete per regolatori e filtroregolatori G1/4"

adaptor for side mounting - regulators and filter-regulators G1/4"

- Si utilizza in posizione intermedia (cod. **16.005.2**) per il fissaggio di FR+L o FRL
*To be used in intermediate position (code **16.005.2**) to install FR+L or FRL*
- Si utilizza come terminale (cod. **16.006.2**) per il fissaggio di FR o REG
*To be used as header (code **16.006.2**) to install FR or REG*
- Materiale: alluminio anodizzato
Material: aluminium (anodize treatment)

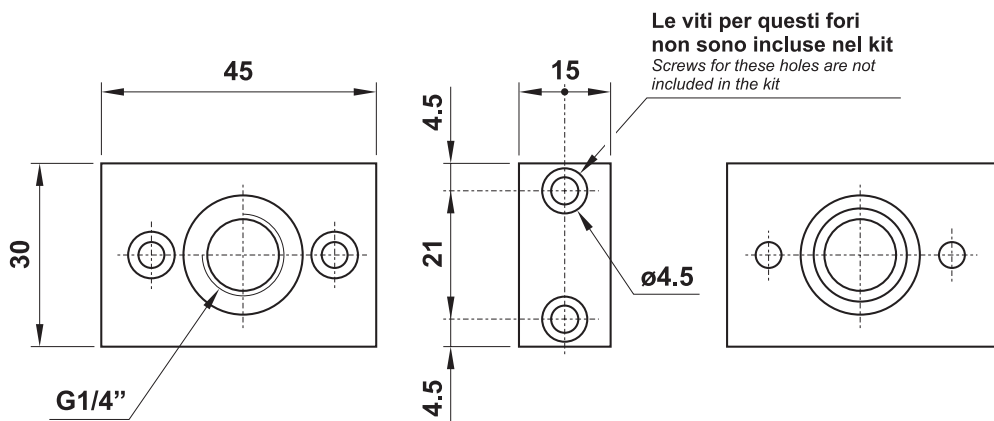

Ogni pezzo è venduto in kit con i particolari necessari al suo assemblaggio
Each element is sold in kit with all necessary pieces for installation

Montaggio in posizione intermedia
Installation in intermediate position

16.005.2

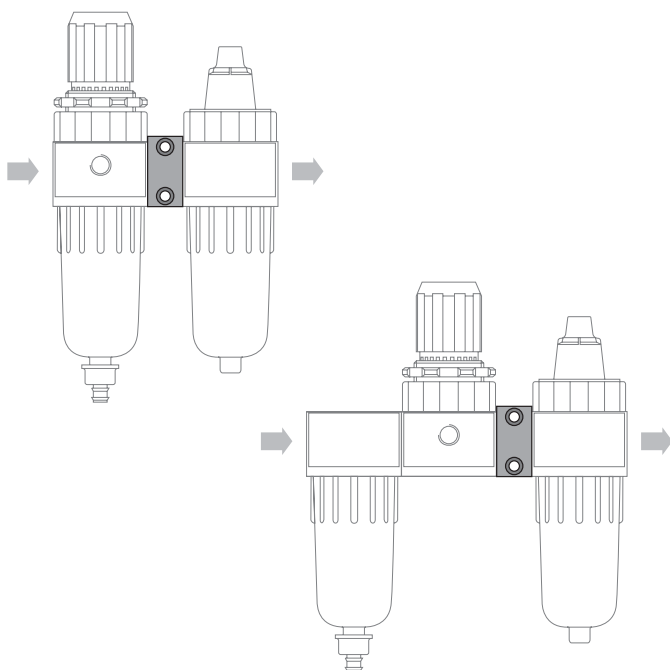

Montaggio come terminale
Installation as header

16.006.2

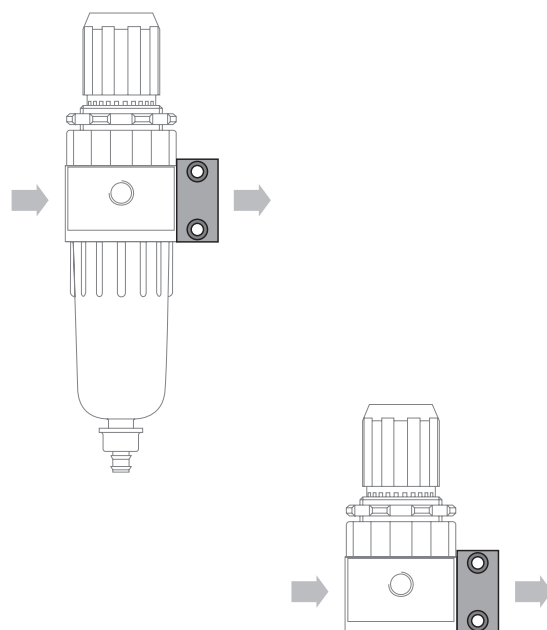

MANOMETRO

manometer

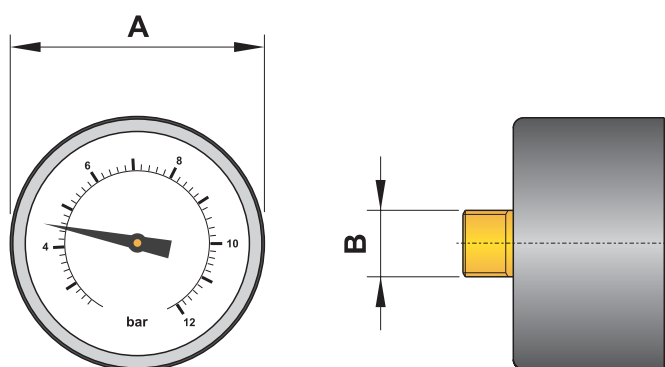

A	B	CODICE DI ORDINAZIONE ORDER CODE
ø40	G1/8"	M40-00
ø50	G1/8"	M50-00
ø63	G1/4"	M63-00

5

NOVITÀ 2005

**nuova serie
gruppi trattamento aria G1”**

new range air preparation units G1”



filtro separatore G1"

G1" filter-water-separator



NUOVO
NEW

- Sistema di funzionamento: gruppo ciclone ed elemento filtrante
Cyclone system and filter element
- Separazione condensa: 96%
Moisture separation: 96%
- Scarico della condensa semiautomatico o automatico
Semi-automatic or automatic moisture exhaust
- Capacità della tazza: 130 cm³
Bowl capacity: 130 cm³
- Installazione verticale; staffe di fissaggio a richiesta (cod. STF 6N)
Vertical installation; brackets on request (code STF 6N)
- Tazza metallica
Metal bowl



CODICE DI ORDINAZIONE ORDER CODE		FIL 6N-30-S	FIL 6N-30-A	FIL 6N-05-S
Attacchi <i>Ports</i>		G1"	G1"	G1"
Scarico della condensa <i>Moisture exhaust</i>		semiautomatico <i>semi-automatic</i>	automatico <i>automatic</i>	semiautomatico <i>semi-automatic</i>
Temperatura di esercizio <i>Temperature range</i>		max +50°C	max +50°C	max +50°C
Peso <i>Weight</i>		0.9 kg	0.9 kg	0.9 kg
Pressione di esercizio <i>Working pressure range</i>	p_{\min} p_{\max}	0 bar; 0 MPa 17.5 bar; 1.75 MPa	0 bar; 0 MPa 17.5 bar; 1.75 MPa	0 bar; 0 MPa 17.5 bar; 1.75 MPa
Portata massima <i>Maximum flow rate</i>	$p = 6.3 \text{ bar}; \Delta p = 1 \text{ bar}$	Q_{\max} 10000 NI/min	10000 NI/min	10000 NI/min
Elemento filtrante <i>Filter element</i>		30 μm	30 μm	5 μm

Caratteristiche di portata
Flow characteristics

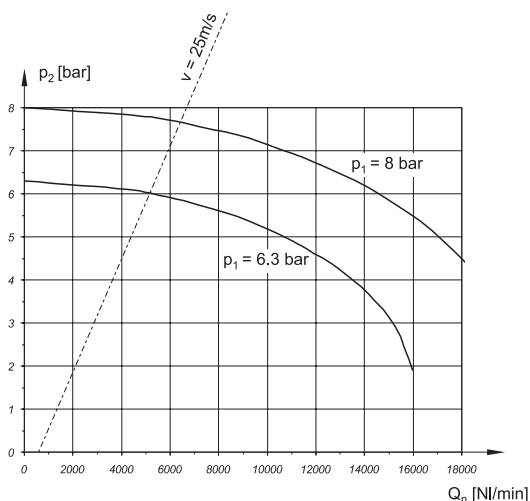

Grado di separazione condensa con $p_1 = 6.3 \text{ bar}$ costante
Moisture separation with $p_1 = 6.3 \text{ bar}$ constant

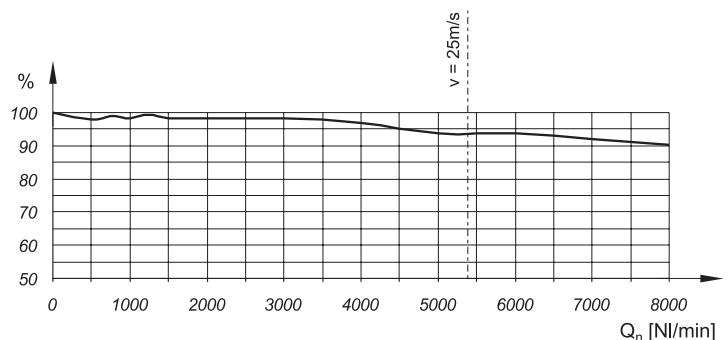

filtro separatore G1"

G1" filter-water-separator



NUOVO
NEW

Le staffe di fissaggio devono essere acquistate separatamente.
Mounting brackets are bought separately.

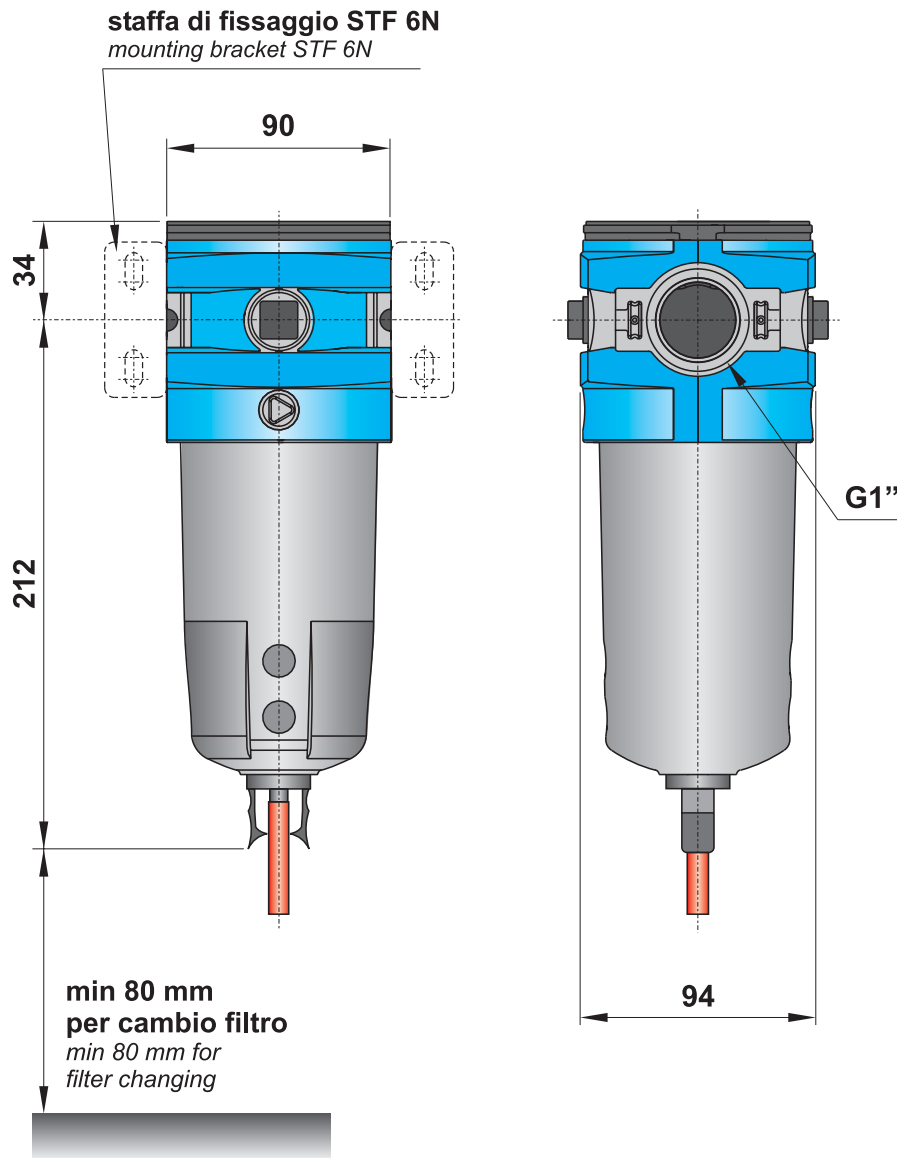
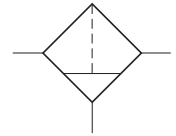

Materiali

Corpo: alluminio pressofuso

Guarnizioni: NBR

Parti interne: ottone e INOX

Parti esterne: polimeri rinforzati

Tazza: metallica

Materials

Body: die-cast aluminium

Seals: NBR

Internal parts: brass and stainless steel

External parts: reinforced polymer

Bowl: metal

regolatore di pressione G1"

G1" pressure regulator



NUOVO
NEW

- Regolatore a membrana con valvola di scarico sovrappressione (relieving)
Diaphragm-type pressure regulator with relieving
- Autocompensazione durante la regolazione
Self-compensated regulation
- Elevata portata
High flow rate
- Grande sensibilità
Sensitive regulation
- Installazione in linea o a pannello; staffe di fissaggio a richiesta (cod. STF 6N; STF 6NA; STF 6NB)
In-line or panel mounting; brackets on request (code STF 6N; STF 6NA; STF 6NB)



CODICE DI ORDINAZIONE <i>ORDER CODE</i>		REG 6N-10
Attacchi <i>Ports</i>		G1"
Temperatura di esercizio <i>Temperature range</i>		max +50°C
Peso <i>Weight</i>		1.2 kg
Pressione di alimentazione <i>Inlet pressure range</i>	$p_{1 \min}$ $p_{1 \max}$	0 bar; 0 MPa 17.5 bar; 1.75 MPa
Pressione di utilizzo <i>Outlet pressure range</i>	$p_{2 \min}$ $p_{2 \max}$	0.5 bar; 0.05 MPa 12 bar; 1.2 MPa
Portata massima <i>Maximum flow rate</i>	$p_1 = 10 \text{ bar}; p_2 = 6.3 \text{ bar}; \Delta p = 1 \text{ bar}$ Q_{\max}	18200 NI/min

Caratteristiche di portata
Flow characteristics

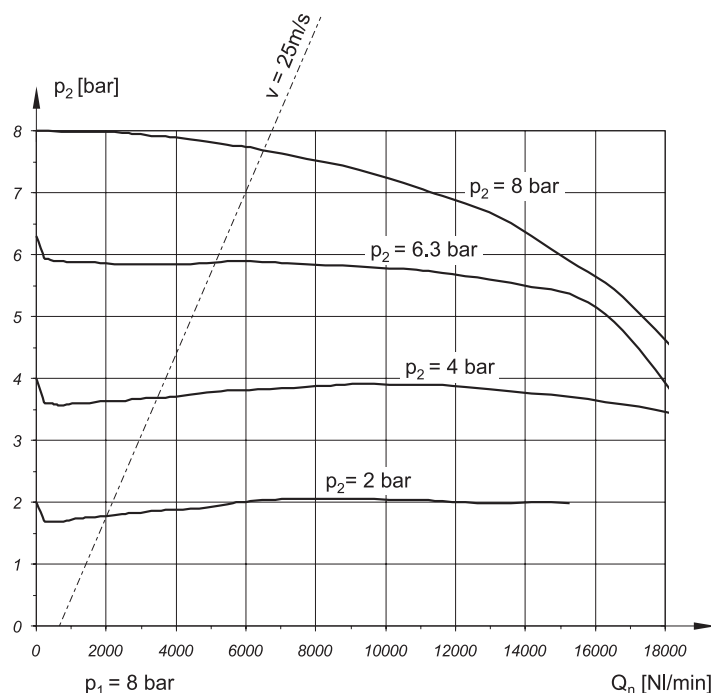

regolatore di pressione G1"

G1" pressure regulator



NUOVO
NEW

Le staffe di fissaggio, la ghiera e il manometro devono essere acquistati separatamente.
Mounting brackets, ring and manometer are bought separately.

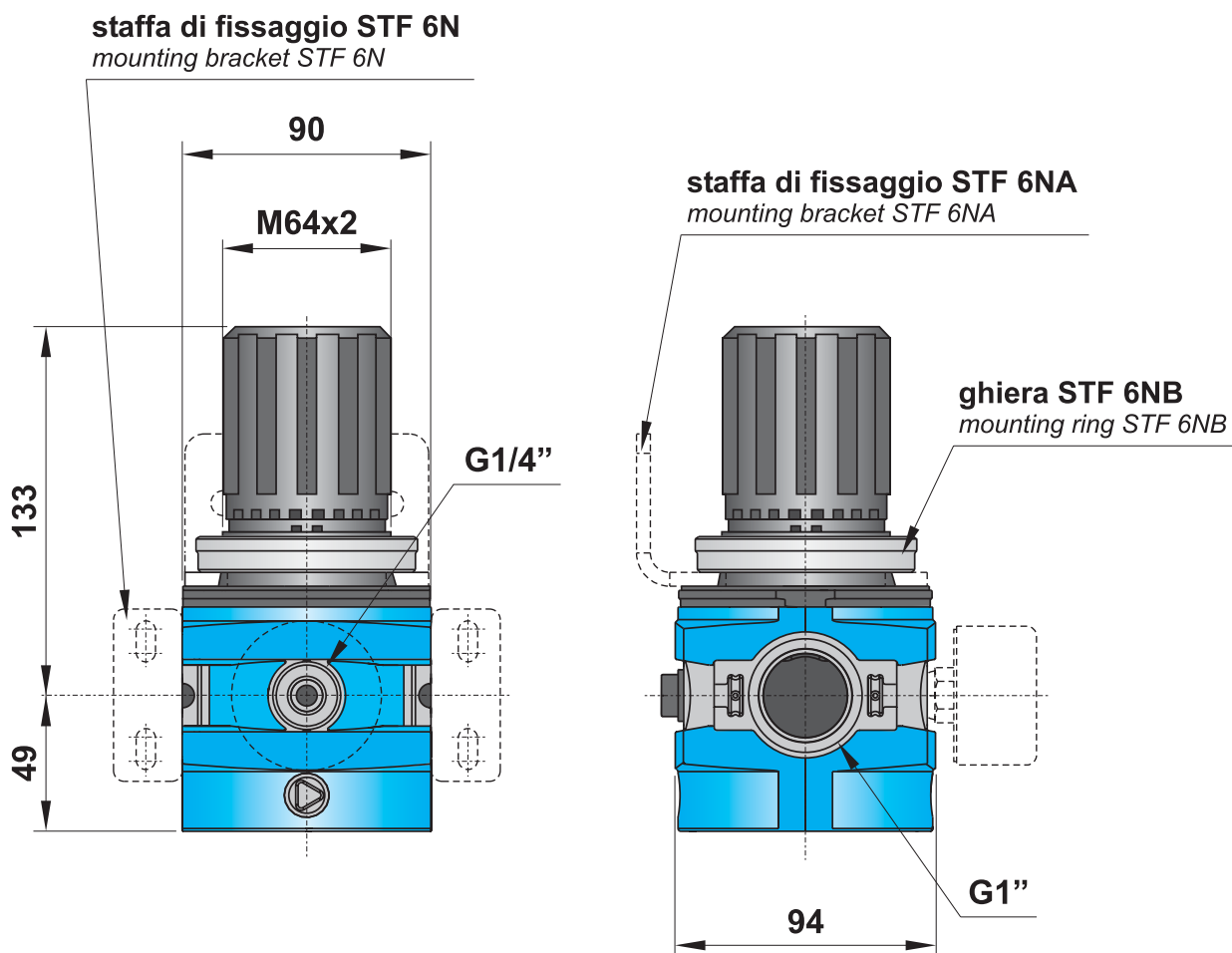
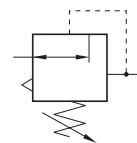

Materiali

Corpo: alluminio pressofuso

Molle: INOX e acciaio zincato

Guarnizioni: NBR

Parti interne: ottone e INOX

Parti esterne: polimeri rinforzati

Materials

Body: die-cast aluminium

Springs: stainless steel and zinc plated steel

Seals: NBR

Internal parts: brass and stainless steel

External parts: reinforced polymer

Lubrificatore G1"

G1" lubricator



NUOVO
NEW

- Lubrificatore venturi con compensazione automatica della portata
Oil mist lubricator with flow compensation
- Il numero di gocce al minuto è costante
Number of drops per minute is constant
- Capacità tazza: 500 cm³
Bowl capacity: 500 cm³
- Rifornimento olio manuale
Manual oil refilling
- Installazione verticale; staffe di fissaggio a richiesta (cod. STF 6N)
Vertical installation; brackets on request (code STF 6N)
- Tazza metallica
Metal bowl



CODICE DI ORDINAZIONE ORDER CODE		LUB 6N-00
Attacchi Ports		G1"
Temperatura di esercizio Temperature range		max +50°C
Peso Weight		0.8 kg
Pressione di esercizio Working pressure range	p_{min} p_{max}	0 bar; 0 MPa 17.5 bar; 1.75 MPa
Portata massima Maximum flow rate	Q_{max}	17700 NI/min
	$p = 6.3 \text{ bar}; \Delta p = 1 \text{ bar}$	

Caratteristiche di portata
Flow characteristics

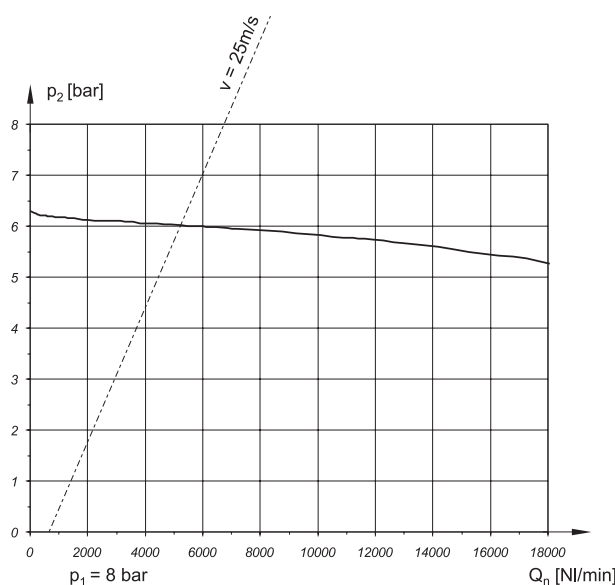

lubrificatore G1"

G1" lubricator



NUOVO
NEW

Le staffe di fissaggio devono essere acquistate separatamente.
Mounting brackets are bought separately.

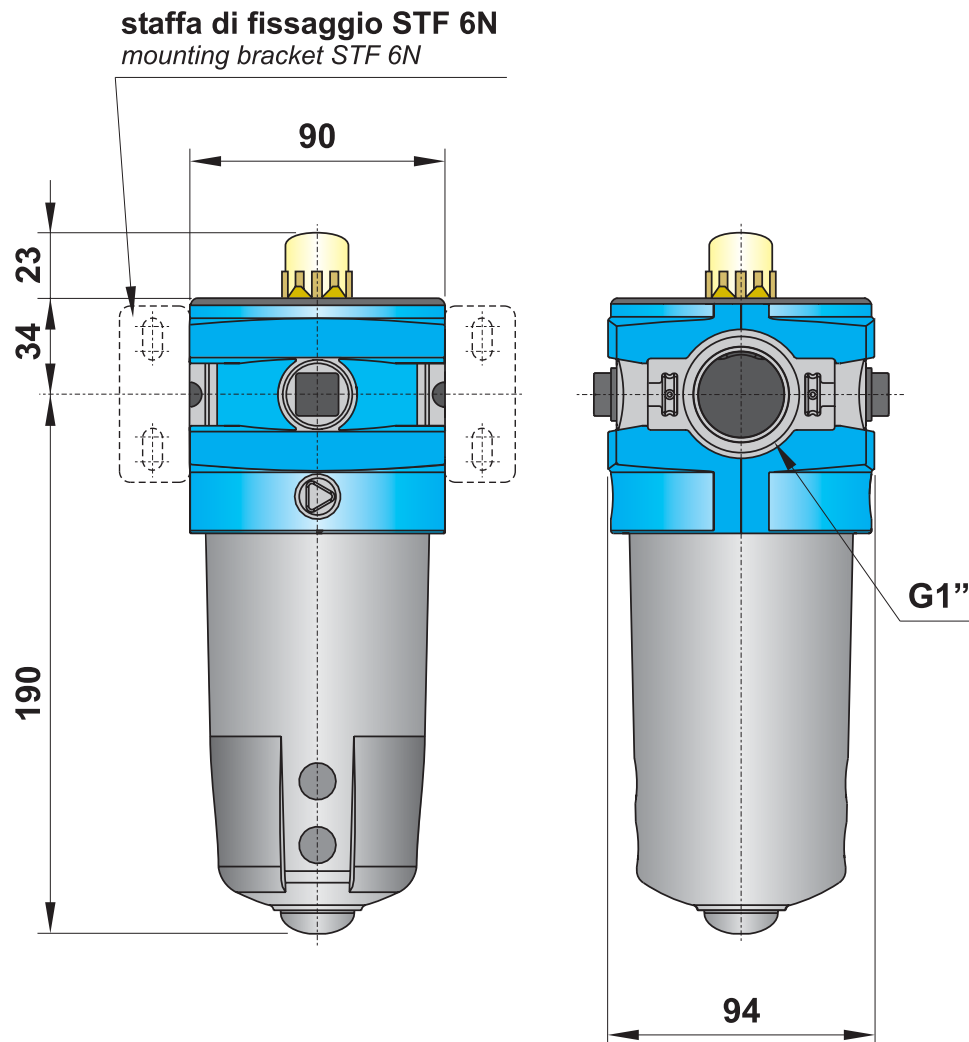
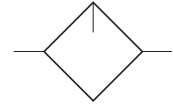

Materiali

Corpo: alluminio pressofuso

Guarnizioni: NBR

Parti interne: ottone e INOX

Parti esterne: polimeri rinforzati

Tazza: metallica

Materials

Body: die-cast aluminium

Seals: NBR

Internal parts: brass and stainless steel

External parts: reinforced polymer

Bowl: metal

filtratore regolatore G1"

G1" filter-regulator



NUOVO
NEW

- Sistema di funzionamento: gruppo ciclone ed elemento filtrante, combinato con regolatore di pressione a diaframma dotato di valvola di scarico sovrappressione (relieving)
Cyclone system and filter element, combined with diaphragm-type pressure regulator (with relieving)
- Separazione condensa: 96%
Moisture separation: 96%
- Scarico semiautomatico della condensa; automatico a richiesta
Semi-automatic moisture exhaust; automatic on request
- Capacità della tazza: 130 cm³; tazza metallica
Bowl capacity: 130 cm³; metal bowl
- Installazione verticale; staffe di fissaggio a richiesta (cod. STF 6N; STF 6NA; STF 6NB)
Vertical installation; brackets on request (code STF 6N; STF 6NA; STF 6NB)



CODICE DI ORDINAZIONE ORDER CODE		FR 6N-10-30-S	FR 6N-10-05-S
Attacchi Ports		G1"	G1"
Temperatura di esercizio Temperature range		max +50°C	max +50°C
Peso Weight		1.5 kg	1.5 kg
Pressione di alimentazione Inlet pressure range	$p_{1 \min}$ $p_{1 \max}$	0 bar; 0 MPa 17.5 bar; 1.75 MPa	0 bar; 0 MPa 17.5 bar; 1.75 MPa
Pressione di utilizzo Outlet pressure range	$p_{2 \min}$ $p_{2 \max}$	0.5 bar; 0.05 MPa 12 bar; 1.2 MPa	0.5 bar; 0.05 MPa 12 bar; 1.2 MPa
Portata massima Maximum flow rate	$p_1 = 10 \text{ bar}; p_2 = 6.3 \text{ bar}; \Delta p = 1 \text{ bar}$	19000 NI/min	19000 NI/min
Elemento filtrante Filter element		30 μm	5 μm

Caratteristiche di portata
Flow characteristics

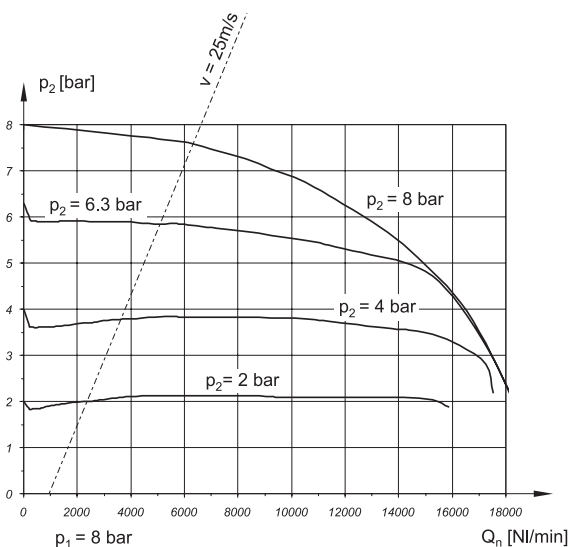

Grado di separazione condensa con $p_1 = 6.3 \text{ bar}$ costante
Moisture separation with $p_1 = 6.3 \text{ bar}$ constant

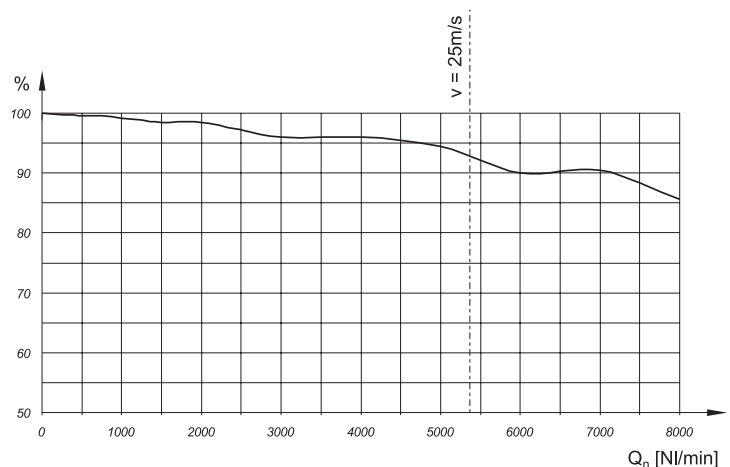

filtratore regolatore G1"

G1" filter-regulator



NUOVO
NEW

Le staffe di fissaggio, la ghiera e il manometro devono essere acquistati separatamente.
Mounting brackets, ring and manometer are bought separately.

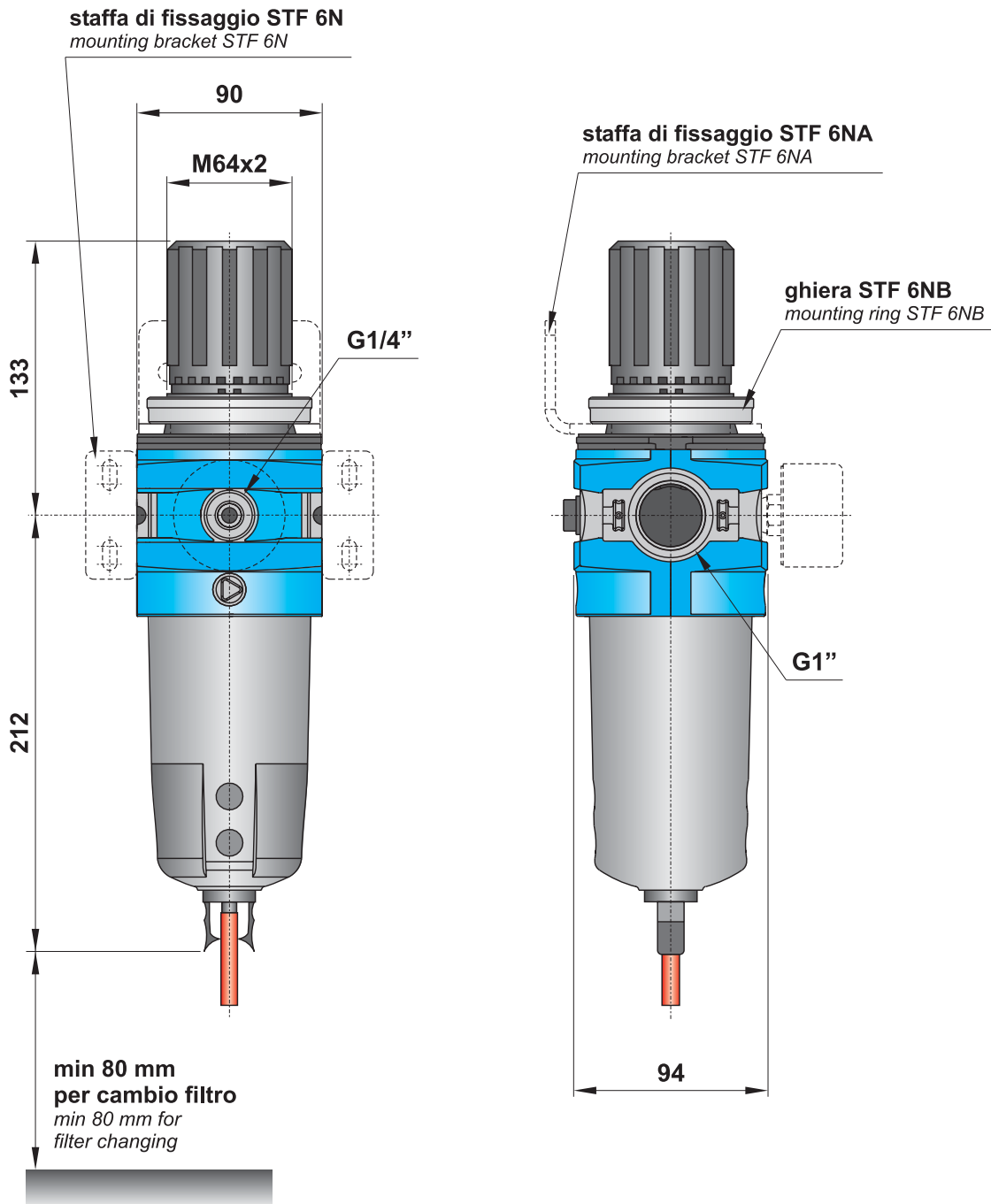

Materiali

Corpo: alluminio pressofuso

Guarnizioni: NBR

Parti interne: ottone e INOX

Parti esterne: polimeri rinforzati

Tazza: metallica

Materials

Body: die-cast aluminium

Seals: NBR

Internal parts: brass and stainless steel

External parts: reinforced polymer

Bowl: metal

gruppo trattamento aria FR+L G1"

G1" FR+L air preparation unit



NUOVO
NEW

- Il gruppo comprende: filtroregolatore e lubrificatore
The unit includes: filter-regulator and oil mist lubricator
- Separazione condensa: 96%
Moisture separation: 96%
- Scarico semiautomatico della condensa; rifornimento olio manuale
Semi-automatic moisture exhaust; manual oil refilling
- Capacità delle tazze: 130 cm³ (condensa), 500 cm³ (olio)
Bowl capacity: 130 cm³ (moisture), 500 cm³ (oil)
- Installazione verticale; staffe di fissaggio a richiesta (cod. STF 6N; STF 6NA; STF 6NB)
Vertical installation; brackets on request (code STF 6N; STF 6NA; STF 6NB)
- Tazza metallica
Metal bowl



CODICE DI ORDINAZIONE ORDER CODE		FR+L 6N-10-30-S
Attacchi <i>Ports</i>		G1"
Temperatura di esercizio <i>Temperature range</i>		max +50°C
Peso <i>Weight</i>		2.8 kg
Pressione di alimentazione <i>Inlet pressure range</i>	$p_{1 \text{ min}}$ $p_{1 \text{ max}}$	0 bar; 0 MPa 17.5 bar; 1.75 MPa
Pressione di utilizzo <i>Outlet pressure range</i>	$p_{2 \text{ min}}$ $p_{2 \text{ max}}$	0.5 bar; 0.05 MPa 12 bar; 1.2 MPa
Portata massima <i>Maximum flow rate</i>	$p_1 = 10 \text{ bar}; p_2 = 6.3 \text{ bar}; \Delta p = 1 \text{ bar}$	Q_{max} 14600 NI/min
Elemento filtrante <i>Filter element</i>		30 μm

Caratteristiche di portata
Flow characteristics

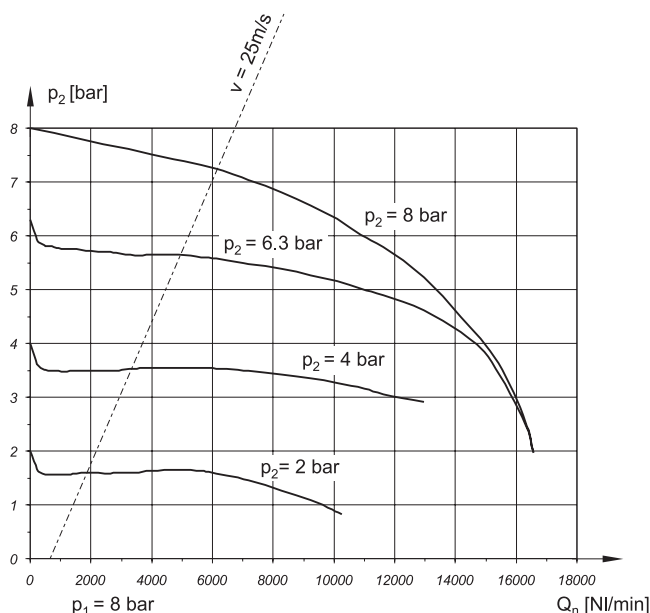

gruppo trattamento aria FR+L G1"

G1" FR+L air preparation unit



NUOVO
NEW

Le staffe di fissaggio, la ghiera e il manometro devono essere acquistati separatamente.
Mounting brackets, ring and manometer are bought separately.

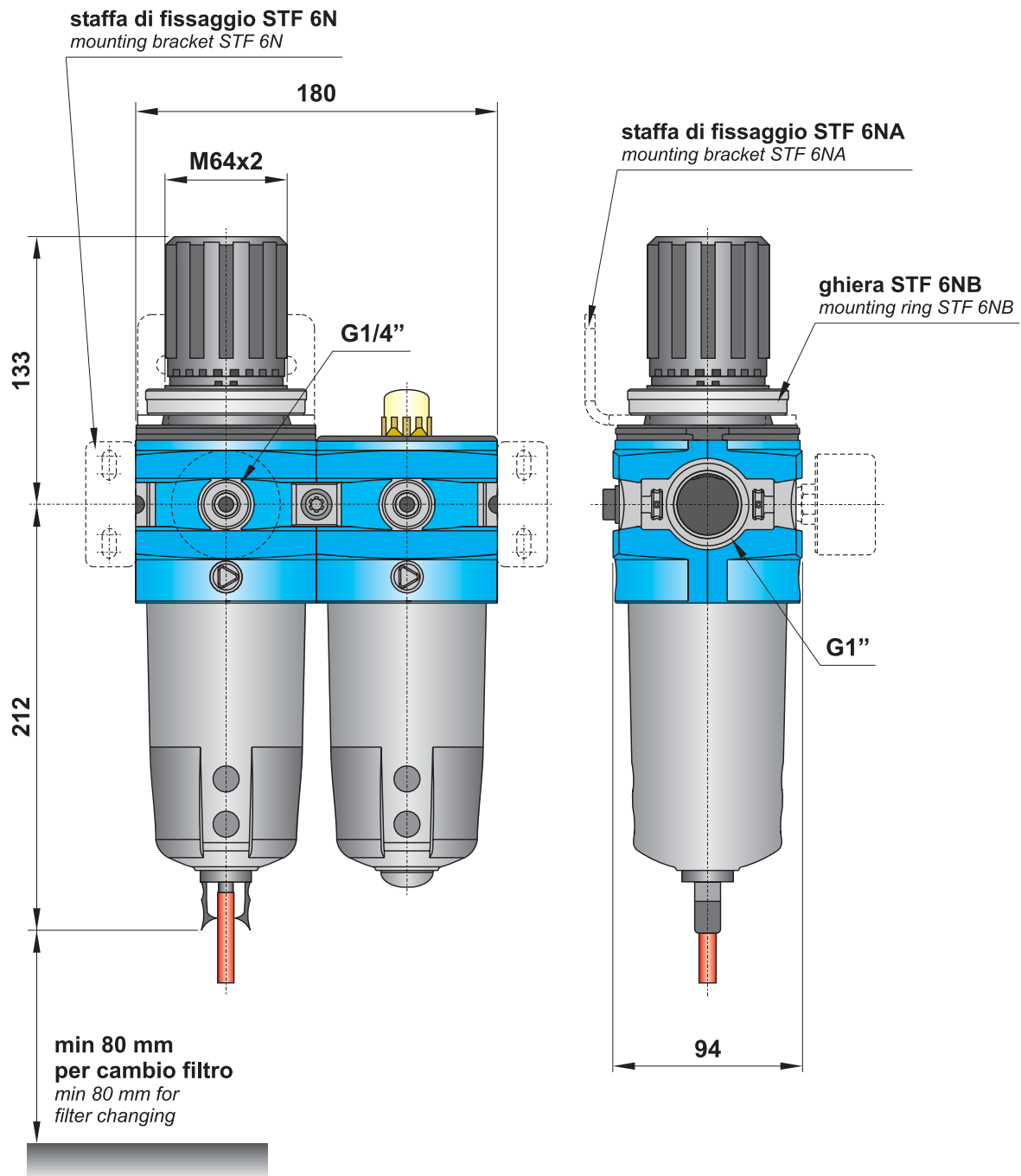
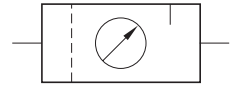

Materiali

Corpo: alluminio pressofuso

Guarnizioni: NBR

Parti interne: ottone e INOX

Parti esterne: polimeri rinforzati

Tazze: metalliche

Materials

Body: die-cast aluminium

Seals: NBR

Internal parts: brass and stainless steel

External parts: reinforced polymer

Bowls: metal

gruppo trattamento aria FRL G1"

G1" FRL air preparation unit



NUOVO
NEW

- Il gruppo comprende: filtro, regolatore di pressione e lubrificatore
The unit includes: filter, pressure regulator and oil mist lubricator
- Separazione condensa: 96%
Moisture separation: 96%
- Scarico semiautomatico della condensa; rifornimento olio manuale
Semi-automatic moisture exhaust; manual oil refilling
- Capacità delle tazze: 130 cm³ (condensa), 500 cm³ (olio)
Bowl capacity: 130 cm³ (moisture), 500 cm³ (oil)
- Installazione verticale; staffe di fissaggio a richiesta (cod. STF 6N; STF 6NA; STF 6NB)
Vertical installation; brackets on request (code STF 6N; STF 6NA; STF 6NB)
- Tazza metallica
Metal bowl



CODICE DI ORDINAZIONE ORDER CODE		FRL 6N-10-30-S
Attacchi <i>Ports</i>		G1"
Temperatura di esercizio <i>Temperature range</i>		max +50°C
Peso <i>Weight</i>		3.3 kg
Pressione di alimentazione <i>Inlet pressure range</i>	$p_{1 \text{ min}}$ $p_{1 \text{ max}}$	0 bar; 0 MPa 17.5 bar; 1.75 MPa
Pressione di utilizzo <i>Outlet pressure range</i>	$p_{2 \text{ min}}$ $p_{2 \text{ max}}$	0.5 bar; 0.05 MPa 12 bar; 1.2 MPa
Portata massima <i>Maximum flow rate</i>	Q_{max}	12600 NI/min
Elemento filtrante <i>Filter element</i>		30 μm

Caratteristiche di portata
Flow characteristics

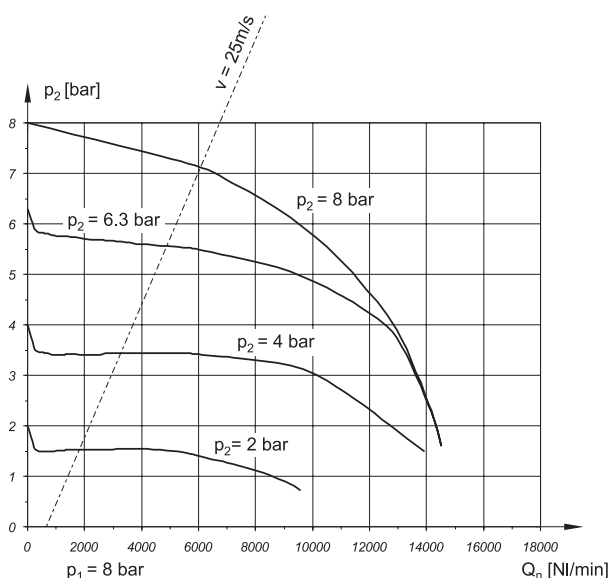

gruppo trattamento aria FRL G1"

G1" FRL air preparation unit



NUOVO
NEW

Le staffe di fissaggio, la ghiera e il manometro devono essere acquistati separatamente.
Mounting brackets, ring and manometer are bought separately.

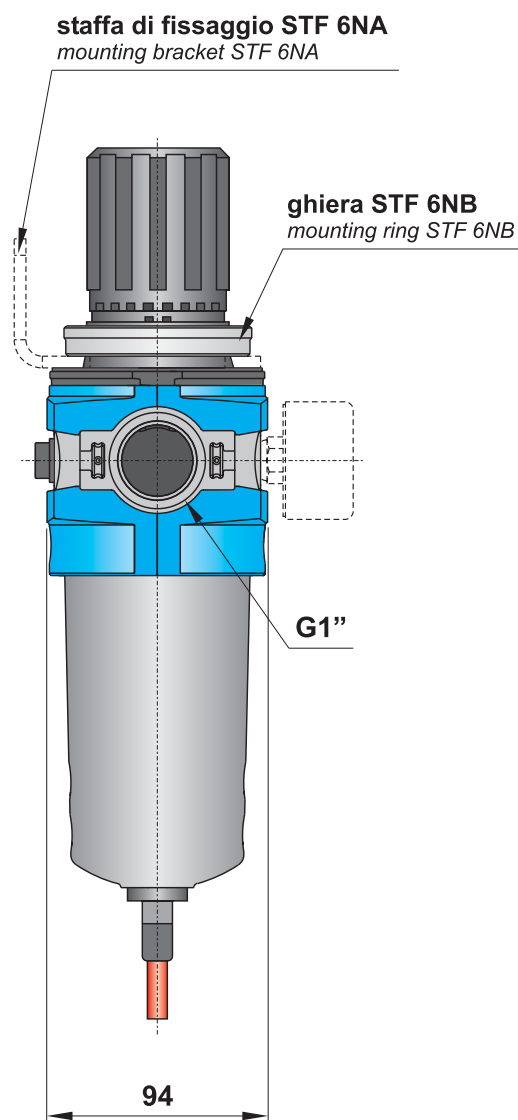
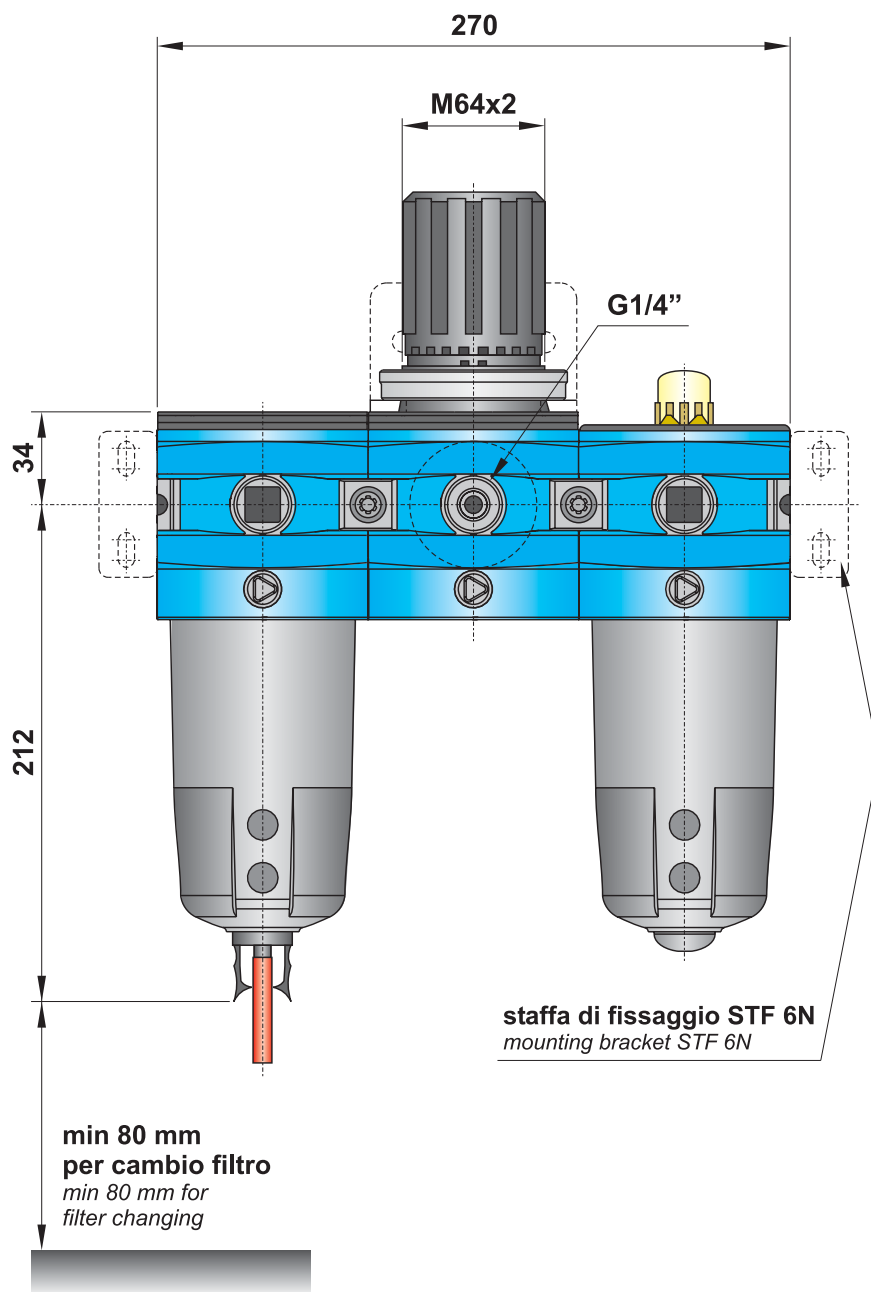
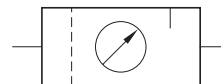

Materiali

Corpo: alluminio pressofuso

Guarnizioni: NBR

Parti interne: ottone e INOX

Parti esterne: polimeri rinforzati

Tazze: metalliche

Materials

Body: die-cast aluminium

Seals: NBR

Internal parts: brass and stainless steel

External parts: reinforced polymer

Bowls: metal

STAFFE E GHIERA DI FISSAGGIO

mounting brackets and ring

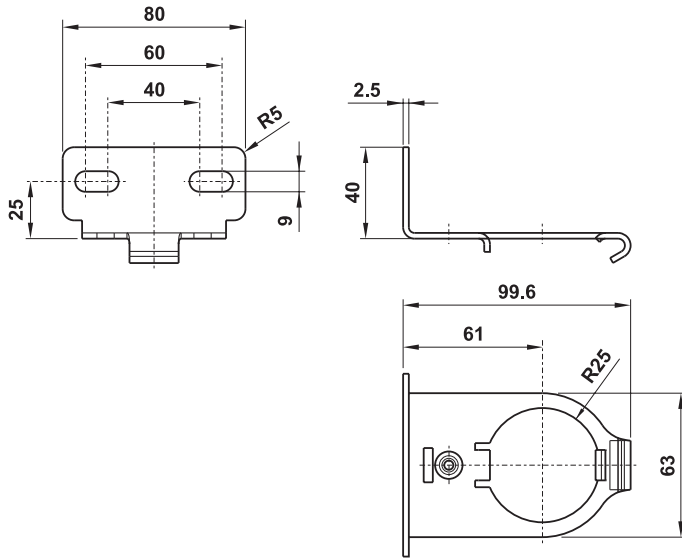

G1"

CODICE DI ORDINAZIONE
ORDER CODE

STF 6N

La sigla si riferisce a una coppia di staffe
The part number is referred to a couple of brackets

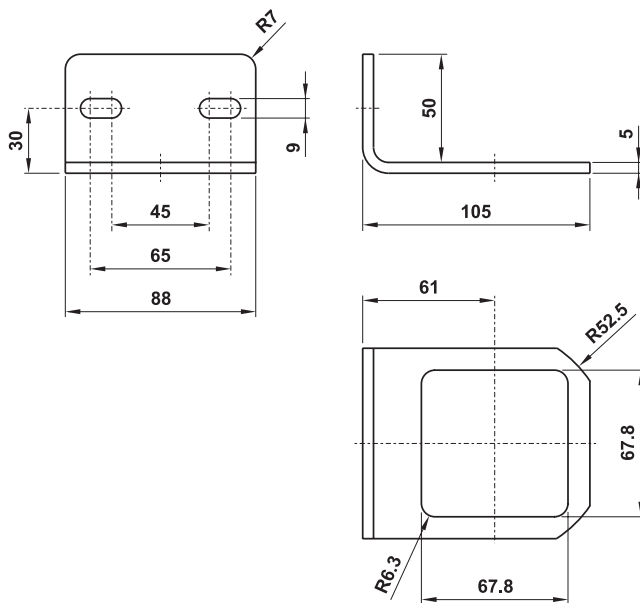

G1"

CODICE DI ORDINAZIONE
ORDER CODE

STF 6NA

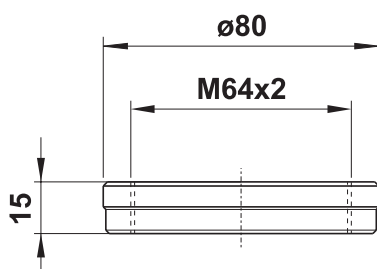

G1"

CODICE DI ORDINAZIONE
ORDER CODE

STF 6NB

5

INDICI ALFANUMERICI

product reference directories

indice alfanumerico ordinato per pagina

product reference directory - ordered by catalogue page



sigla part number	codice code	pagina page	sigla part number	codice code	pagina page	sigla part number	codice code	pagina page	sigla part number	codice code	pagina page
304 MA	08.030.4	17	314 MGN	08.247.4	27	321 2PS	00.134.4	38	321 MB90	00.070.4	62
314 MA	08.035.4	17	204 MGR	08.228.4	27	521 2PS	00.019.4	38	321 MBA90	00.041.4	62
204 MA	08.104.4	17	204 MGG	08.229.4	27	321 MR	00.082.4	38	521 MB90	00.071.4	62
304 MB	08.031.4	17	204 MG	08.230.4	27	521 MR	00.083.4	39	321 BB90	00.141.4	63
314 MB	08.036.4	17	204 MGN	08.231.4	27	321 MRU	00.084.4	39	521 BB90	00.138.4	63
204 MB	08.105.4	17	304 MGR UL	08.216.4	27	521 MRU	00.085.4	39	RM 010	RM 010	64
304 MR	08.032.4	18	304 MGG UL	08.217.4	27	321 MRS	00.086.4	40	P 22804 V	P 22804 V	64
314 MR	08.037.4	18	304 MG	08.218.4	27	321 MRSA	00.087.4	40	P 22804 G	P 22804 G	64
204 MR	08.111.4	18	304 MGN UL	08.219.4	27	521 MRS	00.088.4	40	P 22804 A	P 22804 A	64
304 MS	08.033.4	18	314 MGR UL	08.248.4	27	321 MN	00.089.4	41	P 22804 B	P 22804 B	64
314 MS	08.038.4	18	314 MGG UL	08.249.4	27	321 MNA	00.090.4	41	RM 050 R	RM 050 R	64
204 MS	08.117.4	18	314 MG	08.250.4	27	521 MN	00.091.4	41	RM 050 N	RM 050 N	64
304 MV	08.034.4	19	314 MGN UL	08.251.4	27	321 ML90	00.052.4	43	RM 055 R	RM 055 R	64
314 MV	08.116.4	19	204 MGR UL	08.232.4	27	521 ML90	00.054.4	43	RM 055 N	RM 055 N	64
204 MV	08.125.4	19	204 MGG UL	08.233.4	27	321 LL90	00.053.4	44	RM 065 R	RM 065 R	64
304 MA UL	08.050.4	19	204 MG	08.234.4	27	521 LL90	00.055.4	44	RM 056 R	RM 056 R	64
314 MA UL	08.060.4	19	204 MGN UL	08.235.4	27	321 CL90	00.139.4	45	RM 066 R	RM 066 R	64
204 MA UL	08.172.4	19	305 MGR	08.220.4	28	521 CL90	00.140.4	45	RM 300 N	RM 300 N	65
304 MB UL	08.051.4	20	305 MGG	08.221.4	28	5213C ML90	00.056.4	46	RM 350 N	RM 350 N	65
314 MB UL	08.061.4	20	305 MG	08.222.4	28	5213A ML90	00.058.4	46	RM 313 N	RM 313 N	65
204 MB UL	08.130.4	20	305 MGN	08.223.4	28	5213P ML90	00.042.4	46	RM 383 N	RM 383 N	65
304 MR UL	08.052.4	20	315 MGR	08.252.4	28	5213C LL90	00.057.4	46	RM 400 N	RM 400 N	65
314 MR UL	08.062.4	20	315 MGG	08.253.4	28	5213A LL90	00.059.4	46	RM 450 N	RM 450 N	65
204 MR UL	08.196.4	20	315 MG	08.254.4	28	5213P LL90	00.060.4	46	RM 413 N	RM 413 N	65
304 MS UL	08.053.4	21	315 MGN	08.255.4	28	321 MT	00.075.4	47	RM 483 N	RM 483 N	65
314 MS UL	08.063.4	21	205 MGR	08.236.4	28	521 MT	00.076.4	47	RM 200 N	RM 200 N	65
204 MS UL	08.160.4	21	205 MGG	08.237.4	28	321 TT	00.068.4	47	PED 502 M	01.052.4	67
304 MV UL	08.054.4	21	205 MG	08.238.4	28	521 TT	00.069.4	48	PED 502 S	01.072.4	67
314 MV UL	08.158.4	21	205 MGN	08.239.4	28	321 CT	00.110.4	48	PED 502 B	01.053.4	67
204 MV UL	08.149.4	21	305 MGR UL	08.224.4	28	321 CTT	00.004.4	48	PEDS 502 M	01.080.4	67
305 MA	08.040.4	22	305 MGG UL	08.225.4	28	521 CT	00.111.4	49	PEDS 502 B	01.081.4	67
315 MA	08.045.4	22	305 MG	08.226.4	28	521 CTT	00.005.4	49		08.197.4	68
205 MA	08.141.4	22	305 MGN UL	08.227.4	28	5213A ML	00.151.4	50		08.198.4	68
305 MB	08.041.4	22	315 MGR UL	08.256.4	28		00.136.3	50		08.207.4	68
315 MB	08.046.4	22	315 MGG UL	08.257.4	28		00.137.3	50	PED 304 M	08.184.4	68
205 MB	08.157.4	22	315 MG	08.258.4	28		00.138.3	50		01.087.0	69
305 MR	08.042.4	23	315 MGN UL	08.259.4	28		00.139.3	50		01.088.0	69
315 MR	08.047.4	23	205 MGR UL	08.240.4	28		00.163.4	51	431 MP	05.136.4	71
205 MR	08.173.4	23	205 MGG UL	08.241.4	28		00.160.4	51	451 MP	05.137.4	71
305 MS	08.043.4	23	205 MG	08.242.4	28		00.164.4	51	431 MR	05.138.4	72
315 MS	08.048.4	23	205 MGN UL	08.243.4	28	321 LL	00.050.4	52	451 MR	05.139.4	72
205 MS	08.185.4	23	504 MB	08.064.4	29	521 LL	00.051.4	52	431 MRL	05.140.4	73
305 MV	08.044.4	24	2.304 MB	08.085.4	29	322 ML90	01.054.4	53	451 MRL	05.141.4	73
315 MV	08.153.4	24	2.314 MB	08.089.4	29	522 ML90	01.056.4	53	431 MGR	05.142.4	74
205 MV	08.186.4	24	505 MB	08.094.4	29	322 LL90	01.055.4	54	431 MGG	05.143.4	74
305 MA UL	08.055.4	24	2.305 MB	08.146.4	29	522 LL90	01.057.4	54	431 MG	05.144.4	74
315 MA UL	08.151.4	24	2.315 MB	08.192.4	29	322 CL90	01.082.4	55	431 MGN	05.145.4	74
205 MA UL	08.169.4	24	504 MB UL	08.065.4	30	522 CL90	01.065.4	55	451 MGR	05.146.4	74
305 MB UL	08.056.4	25	2.304 MB UL	08.067.4	30	5223C ML90	01.061.4	56	451 MGG	05.147.4	74
315 MB UL	08.175.4	25	2.314 MB UL	08.068.4	30	5223A ML90	01.062.4	56	451 MG	05.148.4	74
205 MB UL	08.187.4	25	505 MB UL	08.193.4	30	5223P ML90	01.063.4	56	451 MGN	05.149.4	74
305 MR UL	08.057.4	25	2.305 MB UL	08.194.4	30	5223C LL90	01.059.4	56	321 MC	00.022.4	76
315 MR UL	08.188.4	25	2.315 MB UL	08.195.4	30	5223A LL90	01.060.4	56	321 MCA	00.023.4	76
205 MR UL	08.119.4	25	305 LL	03.011.4	31	5223P LL90	01.058.4	56	521 MC	00.027.4	76
305 MS UL	08.058.4	26	504 MB CU	08.087.4	31	322 MT	01.066.4	57	321 CC	00.025.4	77
315 MS UL	08.152.4	26	2.304 MB CU	08.086.4	31	522 MT	01.068.4	57	321 CCD	00.024.4	77
205 MS UL	08.189.4	26		08.017.2	31	322 TT	01.067.4	57	321 CFP	00.021.4	77
305 MV UL	08.059.4	26		08.015.2	31	522 TT	01.069.4	58	521 CC	00.028.4	78
315 MV UL	08.190.4	26	321 MP	00.077.4	35	322 CT	01.041.4	58	521 CCD	00.030.4	78
205 MV UL	08.191.4	26	521 MP	00.078.4	35	322 CTT	01.078.4	58	521 CFP	00.029.4	78
304 MGR	08.212.4	27	321 2P	00.133.4	35	522 CT	01.042.4	59	5213C CC	00.031.4	79
304 MGG	08.213.4	27	521 2P	00.036.4	36	522 CTT	01.079.4	59	5213A CC	00.032.4	79
304 MG	08.214.4	27	321 CP	00.135.4	36	322 LL	01.049.4	60	5213P CC	00.043.4	79
304 MGN	08.215.4	27	521 CP	00.136.4	36	522 LL	01.050.4	60	5223C CC	01.034.4	79
314 MGR	08.244.4	27	321 MPS	00.079.4	37	321 MB	00.072.4	61	5223A CC	01.035.4	79
314 MGG	08.245.4	27	321 MPSA	00.080.4	37	321 MBA	00.061.4	61	5223P CC	01.073.4	79
314 MG	08.246.4	27	521 MPS	00.081.4	37	521 MB	00.073.4	61	322 MC	01.022.4	80

indice alfanumerico ordinato per pagina

product reference directory - ordered by catalogue page



sigla part number	codice code	pagina page	sigla part number	codice code	pagina page	sigla part number	codice code	pagina page	sigla part number	codice code	pagina page
322 MC SUP	01.037.4	80		00.197.0	98	5213C EE AS	00.039.3	109		00.054.2	125
322 MCA	01.023.4	80		00.344.0	98	5213A EE AS	00.040.3	109		00.055.2	125
522 MC	01.027.4	81		00.345.0	98	5213P EE AS	00.041.3	109		00.056.2	125
522 MC SUP	01.074.4	81		00.346.0	98	321 ME90 S	00.005.3	110		00.057.2	125
322 CC	01.025.4	81		00.347.0	98	321 ME90 L	00.059.3	110		00.058.2	125
322 CCD	01.024.4	82		00.394.0	98	521 ME90 S	00.007.3	111		00.059.2	125
322 CFP	01.021.4	82		00.395.0	98	521 ME90 L	00.061.3	111		00.060.2	125
322 CC SUP	01.036.4	82		00.258.0	99	321 EE90 S	00.006.3	112		01.042.2	125
522 CC	01.028.4	83		00.259.0	99	321 EE90 L	00.060.3	112		01.043.2	125
522 CCD	01.030.4	83		00.260.0	99	521 EE90 S	00.009.3	113		01.044.2	125
522 CFP	01.029.4	83		00.261.0	99	521 EE90 L	00.062.3	113		01.045.2	125
522 CC SUP	01.070.4	84		00.251.0	99	322 ME	01.011.3	114		01.046.2	125
322 ORM	01.009.4	84		00.348.0	99	322 MEA	01.017.3	114		01.047.2	125
322 ANDM	01.010.4	84		00.349.0	99	322 CE	01.029.3	114		01.048.2	125
322 2OR	01.011.4	85		00.350.0	99	522 ME	01.009.3	115		00.064.2	126
322 2AND	01.012.4	85		00.351.0	99	522 CE	01.020.3	115		00.080.2	126
522 ORM	01.001.4	86		00.396.0	99	322 ME AS	01.018.3	115		01.049.2	126
522 ANDM	01.002.4	86		00.397.0	99	522 ME AS	01.019.3	116		01.050.2	126
522 2OR	01.005.4	87		00.284.0	100	322 EE	01.012.3	116		00.095.2	127
522 2AND	01.006.4	87		00.305.0	100	322 EED	01.039.3	116		00.029.2	128
321 MCQ	00.010.4	88		00.332.0	100	322 EFP	01.049.3	117		00.067.2	128
321 MCS	00.015.4	88		00.393.0	100	522 EE	01.010.3	117		01.029.2	128
521 MCQ	00.011.4	88		00.333.0	100	522 EED	01.040.3	117		01.038.2	128
521 MCS	00.016.4	89		00.336.0	100	522 EFP	01.045.3	118		00.042.3	128
322 MCS	01.083.4	89		00.392.0	100	322 EE AS	01.050.3	118		00.043.3	128
522 MCS	01.004.4	89		00.370.0	100	522 EE AS	01.052.3	118		00.044.3	128
	00.071.3	90		AU.061.1	101	5223C EE	01.021.3	119		00.045.3	128
	00.088.3	90		AU.062.1	101	5223A EE	01.022.3	119		00.046.3	128
	00.051.3	90		AU.063.1	101	5223P EE	01.023.3	119		01.032.3	128
	01.068.3	90		AU.064.1	101	5223C EE AS	01.024.3	119		01.033.3	128
	01.066.3	90		AU.065.1	101	5223A EE AS	01.025.3	119		01.034.3	128
	01.005.3	90		AU.066.1	101	5223P EE AS	01.026.3	119		01.035.3	128
	00.004.3	91		AU.067.1	101		00.036.2	120		01.036.3	128
	00.064.3	91		AU.068.1	101		00.039.2	120		02.030.2	129
	00.072.3	92		AU.069.1	101		00.037.2	120		02.031.2	129
	00.073.3	92		AU.070.1	101		00.040.2	120		02.032.2	129
	00.074.3	92		00.093.2	101		01.014.2	120		02.033.2	129
	00.075.3	92		00.253.0	102		01.020.2	120	324 MC	02.001.4	130
	00.076.3	92		00.254.0	102		01.015.2	120	324 MCA	02.002.4	130
	00.077.3	92		00.255.0	102		01.021.2	120	324 CFP	02.003.4	130
	00.078.3	92		00.256.0	102		00.038.2	120	324 CC	02.004.4	130
	00.079.3	92		00.257.0	102		00.041.2	120	324 CCD	02.005.4	130
	00.080.3	92		00.252.0	102		01.019.2	120	524 MC	02.006.4	131
	00.052.3	92		00.340.0	102		01.022.2	120	524 CFP	02.007.4	131
	00.053.3	92		00.341.0	102		00.050.2	120	524 CC	02.008.4	131
	00.054.3	92		00.342.0	102		01.035.2	120	524 CCD	02.009.4	131
	00.055.3	92		00.343.0	102		00.051.2	120	5243C CC	02.010.4	131
	00.056.3	92		00.398.0	102		01.036.2	120	5243A CC	02.011.4	131
	00.094.3	94		00.399.0	102		00.108.2	120	5243P CC	02.012.4	131
	00.095.3	94	321 ME	00.015.3	104		01.061.2	120	324 ME	02.001.3	134
	00.096.3	95	321 MEA	00.010.3	104		00.021.3	123	324 MEA	02.002.3	134
	00.130.3	95	321 CE	00.032.3	104		01.032.4	123	324 ME AS	02.003.3	134
	00.097.3	95	521 ME	00.013.3	105		00.024.3	123	324 EFP	02.004.3	134
	00.131.3	95	521 CE	00.035.3	105		00.023.3	123	324 EE	02.005.3	135
	00.098.3	96	321 ME AS	00.033.3	105		01.045.4	123	324 EE AS	02.006.3	135
	00.099.3	96	521 ME AS	00.034.3	106		01.033.4	123	324 EED	02.007.3	135
	00.100.3	97	321 EE	00.016.3	106		00.011.3	123	524 ME	02.008.3	136
	00.134.3	97	321 EED	00.050.3	106		01.007.3	123	524 ME AS	02.009.3	136
	00.101.3	97	321 EFP	00.065.3	107		00.078.2	123	524 EFP	02.010.3	136
	00.135.3	97	521 EE	00.014.3	107		01.078.2	123	524 EE	02.011.3	137
	00.167.0	98	521 EED	00.049.3	107		00.044.4	124	524 EE AS	02.012.3	137
	00.028.0	98	521 EFP	00.063.3	108		01.048.4	124	524 EED	02.013.3	137
	00.029.0	98	321 EE AS	00.066.3	108		00.049.4	124	5243C EE	02.014.3	137
	00.030.0	98	521 EE AS	00.067.3	108		01.047.4	124	5243A EE	02.015.3	137
	00.031.0	98	5213C EE	00.036.3	109		00.045.4	124	5243P EE	02.016.3	137
	00.088.0	98	5213A EE	00.037.3	109		00.052.2	125	5243C EE AS	02.017.3	137
	00.306.0	98	5213P EE	00.038.3	109		00.053.2	125	5243A EE AS	02.018.3	137

indice alfanumerico ordinato per pagina

product reference directory - ordered by catalogue page



sigla part number	codice code	pagina page	sigla part number	codice code	pagina page	sigla part number	codice code	pagina page	sigla part number	codice code	pagina page
5243P EE AS	02.019.3	137		05.054.1	153	731 EE AS 02	05.032.4	165		01.065.2	174
851 MC	05.077.4	140		05.055.1	153	731 EE AS 03	05.033.4	165		01.066.2	174
851 CC	05.078.4	140		05.056.1	153	731 EE AS 04	05.034.4	165	382 MC	01.013.4	175
851 CCD	05.079.4	141		05.057.1	153	751 EE AS 00	05.055.4	165	582 MC	01.008.4	175
851 CFP	05.135.4	141		05.058.1	153	751 EE AS 01	05.056.4	165	382 CC	01.014.4	175
8513C CC	05.150.4	142		05.059.1	153	751 EE AS 02	05.057.4	165	582 CC	01.015.4	175
8513A CC	05.151.4	142		05.060.1	153	751 EE AS 03	05.058.4	165	382 ME	01.041.3	176
851 ME 00	05.072.4	144		05.113.1	153	751 EE AS 04	05.059.4	165	582 ME	01.037.3	176
851 ME 01	05.073.4	144		05.114.1	153	7513C EE 00	05.060.4	166	382 EE	01.003.3	176
851 ME 02	05.074.4	144	731 MC	05.001.4	155	7513C EE 01	05.061.4	166	582 EE	01.038.3	176
851 ME 03	05.075.4	144	731 MCA	05.071.4	155	7513C EE 02	05.062.4	166		01.055.2	178
851 ME 04	05.076.4	144	751 MC	05.005.4	155	7513C EE 03	05.063.4	166	152 MC	00.095.4	180
851 ME AS 00	05.100.4	144	731 CC	05.002.4	156	7513C EE 04	05.064.4	166	152 CC	00.096.4	180
851 ME AS 01	05.101.4	144	751 CC	05.006.4	156	7513A EE 00	05.065.4	166	152 CCD	00.094.4	180
851 ME AS 02	05.102.4	144	731 CCD	05.003.4	157	7513A EE 01	05.066.4	166	152 CFP	00.173.4	180
851 ME AS 03	05.103.4	144	751 CCD	05.007.4	157	7513A EE 02	05.067.4	166	153C CC	00.101.4	180
851 ME AS 04	05.104.4	144	731 CFP	05.004.4	158	7513A EE 03	05.068.4	166	153A CC	00.102.4	180
851 EFP 00	05.120.4	145	751 CFP	05.008.4	158	7513A EE 04	05.069.4	166	153P CC	00.103.4	180
851 EFP 01	05.121.4	145	7513C CC	05.152.4	159	7513C EE AS 00	05.085.4	166	152 ME	00.112.4	181
851 EFP 02	05.122.4	145	7513A CC	05.153.4	159	7513C EE AS 01	05.086.4	166	152 EFP	06.001.4	181
851 EFP 03	05.123.4	145	731 ME 00	05.010.4	161	7513C EE AS 02	05.087.4	166	152 ME AS	00.064.4	181
851 EFP 04	05.124.4	145	731 ME 01	05.011.4	161	7513C EE AS 03	05.088.4	166	152 EE	00.114.4	182
851 EE 00	05.080.4	146	731 ME 02	05.012.4	161	7513C EE AS 04	05.089.4	166	152 EE AS	00.065.4	182
851 EE 01	05.081.4	146	731 ME 03	05.013.4	161	7513A EE AS 00	05.090.4	166	153C EE	00.116.4	182
851 EE 02	05.082.4	146	731 ME 04	05.014.4	161	7513A EE AS 01	05.091.4	166	153A EE	00.117.4	182
851 EE 03	05.083.4	146	731 MEA 00	05.015.4	161	7513A EE AS 02	05.092.4	166	153P EE	00.118.4	182
851 EE 04	05.084.4	146	731 MEA 01	05.016.4	161	7513A EE AS 03	05.093.4	166	153C EE AS	00.066.4	182
851 EE AS 00	05.105.4	146	731 MEA 02	05.017.4	161	7513A EE AS 04	05.094.4	166	153A EE AS	00.067.4	182
851 EE AS 01	05.106.4	146	731 MEA 03	05.018.4	161		05.057.2	167	153P EE AS	00.113.4	182
851 EE AS 02	05.107.4	146	731 MEA 04	05.019.4	161		05.058.2	167		00.048.2	183
851 EE AS 03	05.108.4	146	751 ME 00	05.040.4	161		05.059.2	167		00.047.2	183
851 EE AS 04	05.109.4	146	751 ME 01	05.041.4	161		05.053.2	167		00.049.2	183
8513C EE 00	05.110.4	147	751 ME 02	05.042.4	161		05.054.2	167	MLD1	00.071.2	187
8513C EE 01	05.111.4	147	751 ME 03	05.043.4	161		05.056.2	167	SL1	00.267.1	187
8513C EE 02	05.112.4	147	751 ME 04	05.044.4	161		05.055.2	167		06.001.2	187
8513C EE 03	05.113.4	147	731 ME AS 00	05.020.4	162	BM751	05.025.2	168	TL1	00.083.2	188
8513C EE 04	05.114.4	147	731 ME AS 01	05.021.4	162	DR751	05.027.2	168	TP1	00.068.2	188
8513A EE 00	05.115.4	147	731 ME AS 02	05.022.4	162	DC751	05.026.2	168	TA1	00.073.2	188
8513A EE 01	05.116.4	147	731 ME AS 03	05.023.4	162	TS751	05.024.2	169	TB1	00.082.2	189
8513A EE 02	05.117.4	147	731 ME AS 04	05.024.4	162	TD751	05.023.2	169	TC1	00.077.2	189
8513A EE 03	05.118.4	147	751 ME AS 00	05.045.4	162	DD751	05.028.2	170	DF1	00.307.0	189
8513A EE 04	05.119.4	147	751 ME AS 01	05.046.4	162	CS731	05.022.2	170	TPC1	00.084.2	189
8513C EE AS 00	05.125.4	147	751 ME AS 02	05.047.4	162	CS751	05.021.2	170		00.232.1	190
8513C EE AS 01	05.126.4	147	751 ME AS 03	05.048.4	162		05.035.2	171		00.233.1	190
8513C EE AS 02	05.127.4	147	751 ME AS 04	05.049.4	162		05.012.2	172		00.234.1	190
8513C EE AS 03	05.128.4	147	731 EFP 00	05.035.4	163		05.013.2	172		00.235.1	190
8513C EE AS 04	05.129.4	147	731 EFP 01	05.036.4	163		05.014.2	172		00.236.1	190
8513A EE AS 00	05.130.4	147	731 EFP 02	05.037.4	163		05.015.2	172		00.237.1	190
8513A EE AS 01	05.131.4	147	731 EFP 03	05.038.4	163		05.016.2	172		00.085.2	191
8513A EE AS 02	05.132.4	147	731 EFP 04	05.039.4	163		05.017.2	172		00.086.2	191
8513A EE AS 03	05.133.4	147	751 EFP 00	05.095.4	163		05.018.2	172		00.087.2	191
8513A EE AS 04	05.134.4	147	751 EFP 01	05.096.4	163		05.019.2	172	252 MC	02.050.4	193
	05.050.2	148	751 EFP 02	05.097.4	163		05.020.2	172	252 CC	02.051.4	193
	05.051.2	148	751 EFP 03	05.098.4	163		05.039.2	172	252 CCD	02.052.4	193
	05.052.2	148	751 EFP 04	05.099.4	163		05.036.2	172	252 CFP	02.053.4	193
	05.048.2	148	731 EE 00	05.025.4	164		05.002.2	172	253C CC	02.054.4	193
	05.049.2	148	731 EE 01	05.026.4	164		05.003.2	172	253A CC	02.055.4	193
BM851	05.030.2	149	731 EE 02	05.027.4	164		05.004.2	172	253P CC	02.056.4	193
BS851	05.029.1	149	731 EE 03	05.028.4	164		05.005.2	172	252 ME	02.070.3	194
TS851	05.032.2	150	731 EE 04	05.029.4	164		05.006.2	172	252 EFP	02.072.3	194
TD851	05.031.2	150	751 EE 00	05.050.4	164		05.007.2	172	252 ME AS	02.073.3	194
DR851	05.034.2	151	751 EE 01	05.051.4	164		05.008.2	172	252 EE	02.071.3	195
DC851	05.033.2	151	751 EE 02	05.052.4	164		05.009.2	172	252 EE AS	02.074.3	195
CS851	05.029.2	152	751 EE 03	05.053.4	164		05.010.2	172	253C EE	02.075.3	195
DF851	05.102.2	152	751 EE 04	05.054.4	164		05.037.2	172	253A EE	02.076.3	195
	05.052.1	153	731 EE AS 00	05.030.4	165		05.001.2	172	253P EE	02.077.3	195
	05.053.1	153	731 EE AS 01	05.031.4	165		00.109.2	173	253C EE AS	02.078.3	195

INDEX

indice alfanumerico ordinato per pagina

product reference directory - ordered by catalogue page



sigla part number	codice code	pagina page	sigla part number	codice code	pagina page	sigla part number	codice code	pagina page	sigla part number	codice code	pagina page
253A EE AS	02.079.4	195		08.127.4	210	AZ-SEP3	AU.051.0	223	M22S5...		266
253P EE AS	02.080.4	195		08.121.4	211	AZ-SEP4	AU.076.0	223	M22S6...		266
MLD2	02.001.2	196		08.180.4	212	AZ-SEP5	AU.075.0	223	M22M1...		266
TL2	02.004.2	196		08.181.4	212	AZ-CRS1	18.001.0	224	M22M2...		266
TA2	02.002.2	197		36.625.0	213	AZ-CRS2	18.002.0	224	M22M3...		266
TB2	02.003.2	197		17.005.0	214	AZ-CRS3	18.003.0	224	M22M4...		266
RFU M5	12.047.4	201		17.004.0	214	AZ-CRS4	18.004.0	224	M22M5...		266
RFU 1/8.1	12.010.4	201		17.007.0	214		10.003.3	226	M22M6...		266
RFU 1/8.2	12.000.4	201		17.008.0	214		10.035.4	229	M22A1...		266
RFU 1/8.3	12.000.4-1/4	201		17.011.0	215		10.018.3	230	M22A2...		266
RFU 1/4	12.001.4	201		17.012.0	215		01.044.4	232	M22A3...		266
RFU 3/8	12.002.4	201		17.006.0	216		01.046.4	233	M22A4...		266
RFU 1/2	12.003.4	201		17.010.0	217		01.008.3	234	M22A5...		266
RFUM 1/8	12.004.4	202		17.009.0	217		10.029.4	236	M22A6...		266
RFUM 1/4	12.005.4	202	TRP 8	03.016.4	218		10.027.4	237	M22B1...		266
RFP 1/8.2	12.011.4	202		03.025.4	218		10.017.3	238	M22B2...		266
RFB M5	12.049.4	203	RSW 1/8	11.012.4	219		10.019.3	239	M22B3...		266
RFB 1/8	12.006.4	203	RSW 1/4	11.013.4	219		00.047.4	241	M22B4...		266
RFB 1/4	12.007.4	203	RSW 3/8	11.039.4	219		00.008.3	241	M22B5...		266
RFB 3/8	12.008.4	203	RSW 1/2	11.014.4	219		10.001.4	243	M22B6...		266
RFB 1/2	12.009.4	203	RSTC 1/8	11.017.4	219		10.009.4	244	GPM010	26.140.2	272
VNR M5 FF	11.010.4	205	RSTC 1/4	11.018.4	219		10.003.4	245	GPM12-16	26.141.2	272
	11.011.4	205		AU.002.1	220		10.021.4	246	GPM20-25	26.142.2	272
	11.024.4	205		AU.003.1	220		AX.007.4	247	PDMC08-10	26.101.2N	273
	11.046.4	205		AU.004.1	220		00.074.4	248	PDMC12-16	26.102.2N	273
	11.050.4	205		AU.005.1	220		00.177.4	250	PDMC20-25	26.103.2N	273
VNR 1/8 FF	11.000.4	205		AU.006.1	220		08.156.4	252	FLMC08-10	26.104.2N	274
	11.002.4	205		AU.011.1	220		11.044.4	254	FLMC12-16	26.105.2N	274
	11.004.4	205		AU.013.1	220		11.066.4	254	FLMC20-25	26.106.2N	274
	11.009.4	205		AU.014.1	220		11.076.4	255	CCMC08-10	26.107.2N	275
	11.027.4	205		AU.015.1	220		11.077.4	255	CCMC12-16	26.108.2N	275
	11.031.4	205		AU.016.1	220		10.013.4	256	CCMC20-25	26.109.2N	275
	11.035.4	205		AU.000.1	221		10.014.4	256		20.100.4	277
	11.034.4	205		AU.001.1	221		10.015.4	257		20.101.4	277
VNR 1/8 MF	11.006.4	205		AU.008.1	221		10.016.4	257		20.102.4	277
	11.007.4	205		AU.009.1	221	DP 2010 E	03.020.4	258		20.103.4	277
	11.042.4	205		AU.022.1	221	DP 2018 F	03.003.4	259		20.104.4	277
	11.055.4	205		AU.023.1	221	DP 2005	03.009.4	260		20.105.4	277
	11.045.4	205		AU.024.1	221		AT.005.4	261		20.106.4	277
VNR 1/8 MFR	11.008.4	206		AU.025.1	221	M21S1...		266		20.107.4	277
	11.032.4	206		AU.027.1	221	M21S2...		266		20.108.4	277
	11.049.4	206		AU.017.1	221	M21S3...		266		20.109.4	277
	11.056.4	206		AU.018.1	221	M21S4...		266		20.110.4	277
VNR 1/4 FF	11.001.4	206		AU.019.1	221	M21S5...		266		20.111.4	277
	11.003.4	206		AU.021.1	221	M21S6...		266		20.112.4	277
	11.005.4	206		AU.020.1	221	M21M1...		266		20.113.4	277
	11.030.4	206	AZ-SFE1	AU.042.0	222	M21M2...		266		20.114.4	277
	11.028.4	206	AZ-SFE2	AU.046.0	222	M21M3...		266		20.115.4	277
	11.037.4	206	AZ-SFE3	AU.052.0	222	M21M4...		266		20.116.4	277
	11.036.4	206	AZ-SFE4	AU.058.0	222	M21M5...		266		20.117.4	277
	11.033.4	206	AZ-SFE5	AU.057.0	222	M21M6...		266	T11M2...		279
	11.040.4	206	AZ-SPL2	AU.048.0	222	M21A1...		266	T11M3...		279
VNR 1/4 MF	11.047.4	206	AZ-SPL3	AU.055.0	222	M21A2...		266	T11M4...		279
	11.048.4	206	AZ-SPL4	AU.060.0	222	M21A3...		266	T11M5...		279
	11.059.4	206	AZ-SPL5	AU.059.0	222	M21A4...		266	T12M2...		279
	08.021.4	208	AZ-SE1	AU.043.0	222	M21A5...		266	T12M3...		279
	08.025.4	208	AZ-SE2	AU.047.0	222	M21A6...		266	T12M4...		279
	08.022.4	208	AZ-SE3	AU.054.0	222	M21B1...		266	T12M5...		279
	08.026.4	208	AZ-SE4	AU.072.0	222	M21B2...		266	T13M2...		279
	08.023.4	208	AZ-SE5	AU.071.0	222	M21B3...		266	T13M3...		279
	08.027.4	208	AZ-SC1	AU.040.0	223	M21B4...		266	T13M4...		279
	08.039.4	209	AZ-SC2	AU.044.0	223	M21B5...		266	T13M5...		279
	08.049.4	209	AZ-SC3	AU.053.0	223	M21B6...		266	T21M2...		279
	04.003.4	209	AZ-SC4	AU.074.0	223	M22S1...		266	T21M3...		279
	04.002.4	209	AZ-SC5	AU.073.0	223	M22S2...		266	T21M4...		279
	08.092.1	209	AZ-SEP1	AU.041.0	223	M22S3...		266	T21M5...		279
	08.133.4	210	AZ-SEP2	AU.045.0	223	M22S4...		266	T22M2...		279

indice alfanumerico ordinato per pagina

product reference directory - ordered by catalogue page



sigla part number	codice code	pagina page	sigla part number	codice code	pagina page	sigla part number	codice code	pagina page	sigla part number	codice code	pagina page
T22M3...		279	SGM125P	21.116.2	296	CMSS063	26.082.2N	301	SNINT032B	26.094.2N	307
T22M4...		279	SGM160P	21.117.2	296	CMSS080	26.083.2N	301	SNINT040-050B	26.095.2N	307
T22M5...		279	SGM200P	21.118.2	296	CMSS100	26.084.2N	301	SNINT063-080B	26.097.2N	307
T23M2...		279	SGM032V	21.120.2	296	CMSS125	26.085.2N	301	SNINT100-125B	26.099.2N	307
T23M3...		279	SGM040V	21.121.2	296	CMSS160	26.086.2N	301	CSIS160TI	26.325.2N	308
T23M4...		279	SGM050V	21.122.2	296	CMSS200	26.087.2N	301	CSIS200TI	26.326.2N	308
T23M5...		279	SGM063V	21.123.2	296	CMIS032	26.019.2N	302	COIS032	26.052.2N	309
SGT032	26.192.2N	284	SGM080V	21.124.2	296	CMIS040	26.020.2N	302	COIS040	26.053.2N	309
SGT040	26.193.2N	284	SGM100V	21.125.2	296	CMIS050	26.021.2N	302	COIS050	26.054.2N	309
SGT050	26.194.2N	284	SGM125V	21.126.2	296	CMIS063	26.022.2N	302	COIS063	26.055.2N	309
SGT032V	26.360.2N	284	SGM160V	21.127.2	296	CMIS080	26.023.2N	302	COIS080	26.056.2N	309
SGT040V	26.361.2N	284	SGM200V	21.128.2	296	CMIS100	26.024.2N	302	COIS100	26.057.2N	309
SGT050V	26.362.2N	284	SGM032PV	21.130.2	296	CMIS125	26.025.2N	302	COIS125	26.320.2N	309
SGT032A	26.430.2	284	SGM040PV	21.131.2	296	CMIS160	26.026.2N	302	COIS160	26.322.2N	309
SGT040A	26.431.2	284	SGM050PV	21.132.2	296	CMIS200	26.027.2N	302	COIS200	26.329.2N	309
SGT050A	26.432.2	284	SGM063PV	21.133.2	296	CMKS032	26.028.2N	302	P11M1...		313
SGT032AV	26.433.2	284	SGM080PV	21.134.2	296	CMKS040	26.029.2N	302	P11M2...		313
SGT040AV	26.434.2	284	SGM100PV	21.135.2	296	CMKS050	26.030.2N	302	P11M3...		313
SGT050AV	26.435.2	284	SGM125PV	21.136.2	296	CMKS063	26.031.2N	302	P11M4...		313
GPT032	26.113.2	285	SGM160PV	21.137.2	296	CMKS080	26.032.2N	302	P12M1...		313
GPT040	26.114.2	285	SGM200PV	21.138.2	296	CMKS100	26.033.2N	302	P12M2...		313
GPT050	26.115.2	285	KSM032	21.001.3	297	CMKS125	26.034.2N	302	P12M3...		313
CCR032	26.116.2	285	KSM040	21.002.3	297	CMKS160	26.035.2N	302	P12M4...		313
CCR040	26.117.2	285	KSM050	21.003.3	297	CMKS200	26.036.2N	302	P13M1...		313
CCR050	26.118.2	285	KSM063	21.004.3	297	CFIS032	26.001.2N	303	P13M2...		313
FPT032	26.110.2	286	KSM080	21.005.3	297	CFIS040	26.002.2N	303	P13M3...		313
FPT040	26.111.2	286	KSM100	21.006.3	297	CFIS050	26.003.2N	303	P13M4...		313
FPT050	26.112.2	286	KSM125	21.007.3	297	CFIS063	26.004.2N	303	P21M1...		313
N11M2...		288	KSM160	21.008.3	297	CFIS080	26.005.2N	303	P21M2...		313
N11M4...		288	KSM200	21.009.3	297	CFIS100	26.006.2N	303	P21M3...		313
N11B2...		288	KSM032P	21.011.3	297	CFIS125	26.007.2N	303	P21M4...		313
N11B4...		288	KSM040P	21.012.3	297	CFIS160	26.008.2N	303	P22M1...		313
N12M2...		288	KSM050P	21.013.3	297	CFIS200	26.009.2N	303	P22M2...		313
N12M4...		288	KSM063P	21.014.3	297	CFKS032	26.010.2N	303	P22M3...		313
N12B2...		288	KSM080P	21.015.3	297	CFKS040	26.011.2N	303	P22M4...		313
N12B4...		288	KSM100P	21.016.3	297	CFKS050	26.012.2N	303	P23M1...		313
N13M2...		288	KSM125P	21.017.3	297	CFKS063	26.013.2N	303	P23M2...		313
N13M4...		288	KSM160P	21.018.3	297	CFKS080	26.014.2N	303	P23M3...		313
N13B2...		288	KSM200P	21.019.3	297	CFKS100	26.015.2N	303	P23M4...		313
N13B4...		288	KSM032V	21.021.3	297	CFKS125	26.016.2N	303	P31M1...		313
N21M2...		288	KSM040V	21.022.3	297	CFKS160	26.017.2N	303	P31M2...		313
N21M4...		288	KSM050V	21.023.3	297	CFKS200	26.018.2N	303	P31M3...		313
N21B2...		288	KSM063V	21.024.3	297	FLIS032	26.070.2N	304	P31M4...		313
N21B4...		288	KSM080V	21.025.3	297	FLIS040	26.071.2N	304	P32M1...		313
N22M2...		288	KSM100V	21.026.3	297	FLIS050	26.072.2N	304	P32M2...		313
N22M4...		288	KSM125V	21.027.3	297	FLIS063	26.073.2N	304	P32M3...		313
N22B2...		288	KSM160V	21.028.3	297	FLIS080	26.074.2N	304	P32M4...		313
N22B4...		288	KSM200V	21.029.3	297	FLIS100	26.075.2N	304	P33M1...		313
N23M2...		288	KSM032PV	21.031.3	297	FLIS125	26.076.2N	304	P33M2...		313
N23M4...		288	KSM040PV	21.032.3	297	FLIS160	26.077.2N	304	P33M3...		313
N23B2...		288	KSM050PV	21.033.3	297	FLIS200	26.078.2N	304	P33M4...		313
N23B4...		288	KSM063PV	21.034.3	297	PBIS032	26.037.2N	305	P41M1...		313
SGM032	21.100.2	296	KSM080PV	21.035.3	297	PBIS040	26.038.2N	305	P41M2...		313
SGM040	21.101.2	296	KSM100PV	21.036.3	297	PBIS050	26.039.2N	305	P41M3...		313
SGM050	21.102.2	296	KSM125PV	21.037.3	297	PBIS063	26.040.2N	305	P41M4...		313
SGM063	21.103.2	296	KSM160PV	21.038.3	297	PBIS080	26.041.2N	305	P42M1...		313
SGM080	21.104.2	296	KSM200PV	21.039.3	297	PBIS100	26.042.2N	305	P42M2...		313
SGM100	21.105.2	296		000.510.7	300	PBIS125	26.043.2N	305	P42M3...		313
SGM125	21.106.2	296		000.511.7	300	PBIS160	26.044.2N	305	P42M4...		313
SGM160	21.107.2	296		000.512.7	300	PBIS200	26.045.2N	305	P43M1...		313
SGM200	21.108.2	296		000.513.7	300	CIN032	26.088.2N	306	P43M2...		313
SGM032P	21.110.2	296		000.514.7	300	CIN040	26.089.2N	306	P43M3...		313
SGM040P	21.111.2	296		000.515.7	300	CIN050	26.090.2N	306	P43M4...		313
SGM050P	21.112.2	296		000.516.7	300	CIN063	26.091.2N	306	R11M1...		313
SGM063P	21.113.2	296	CMSS032	26.079.2N	301	CIN080	26.092.2N	306	R11M2...		313
SGM080P	21.114.2	296	CMSS040	26.080.2N	301	CIN100	26.093.2N	306	R11M3...		313
SGM100P	21.115.2	296	CMSS050	26.081.2N	301	CIN125	26.100.2N	306	R11M4...		313

indice alfanumerico ordinato per pagina

product reference directory - ordered by catalogue page



sigla part number	codice code	pagina page	sigla part number	codice code	pagina page	sigla part number	codice code	pagina page	sigla part number	codice code	pagina page
R12M1...		313	GP100PV	25.138.2	317	FLUN032	26.570.2	331	GD040PV	22.134.2	342
R12M2...		313	KP032	25.004.3	326	FLUN040	26.571.2	331	GD050PV	22.135.2	342
R12M3...		313	KP040	25.005.3	326	FLUN050	26.572.2	331	GD063PV	22.136.2	342
R12M4...		313	KP050	25.006.3	326	FLUN063	26.573.2	331	GD080PV	22.137.2	342
R13M1...		313	KP063	25.007.3	326	FLUN080	26.574.2	331	GD100PV	22.138.2	342
R13M2...		313	KP080	25.008.3	326	FLUN100	26.575.2	331	DCCB 16/32 (M5)	26.156.0T	343
R13M3...		313	KP100	25.009.3	326	PBUN032	26.537.2	332	DCCB 32/100 (M6)	26.157.0T	343
R13M4...		313	KR032	25.104.3	326	PBUN040	26.538.2	332	J11M2...		345
R21M1...		313	KR040	25.105.3	326	PBUN050	26.539.2	332	J11M4...		345
R21M2...		313	KR050	25.106.3	326	PBUN063	26.540.2	332	J11M9...		345
R21M3...		313	KR063	25.107.3	326	PBUN080	26.541.2	332	BM012	27.157.0	352
R21M4...		313	KR080	25.108.3	326	PBUN100	26.542.2	332	BM020	27.158.0	352
R22M1...		313	KR100	25.109.3	326	D11M1...		334	BM025	27.159.0	352
R22M2...		313	KP032P	25.014.3	326	D11M2...		334	BM032	27.160.0	352
R22M3...		313	KP040P	25.015.3	326	D11M3...		334	BM040	27.161.0	352
R22M4...		313	KP050P	25.016.3	326	D11M4...		334	BM050	27.162.0	352
R23M1...		313	KP063P	25.017.3	326	D12M1...		334	BM063	27.163.0	352
R23M2...		313	KP080P	25.018.3	326	D12M2...		334	BM080	27.164.0	352
R23M3...		313	KP100P	25.019.3	326	D12M3...		334	BM100	27.165.0	352
R23M4...		313	KR032P	25.114.3	326	D12M4...		334	BM125	27.166.0	352
R31M1...		313	KR040P	25.115.3	326	D13M1...		334	FR8C10	26.119.2	354
R31M2...		313	KR050P	25.116.3	326	D13M2...		334	FR12C16	26.120.2	354
R31M3...		313	KR063P	25.117.3	326	D13M3...		334	FRC20	26.121.2	354
R31M4...		313	KR080P	25.118.3	326	D13M4...		334	FR25C32	26.122.2	354
R32M1...		313	KR100P	25.119.3	326	D21M1...		334	FRC40	26.123.2	354
R32M2...		313	KP032V	25.024.3	326	D21M2...		334	FR50C63	26.124.2	354
R32M3...		313	KP040V	25.025.3	326	D21M3...		334	FR80C100	26.125.2	354
R32M4...		313	KP050V	25.026.3	326	D21M4...		334	FRC125	26.126.2	354
R33M1...		313	KP063V	25.027.3	326	D22M1...		334	FR160C200	26.127.2	354
R33M2...		313	KP080V	25.028.3	326	D22M2...		334	DSMC8-10	26.196.2	355
R33M3...		313	KP100V	25.029.3	326	D22M3...		334	DSMC12-16	26.197.2	355
R33M4...		313	KR032V	25.124.3	326	D22M4...		334	DSMC20	26.198.2	355
R41M1...		313	KR040V	25.125.3	326	D23M1...		334	DSIS032	21.750.0	355
R41M2...		313	KR050V	25.126.3	326	D23M2...		334	DSIS040	21.751.0	355
R41M3...		313	KR063V	25.127.3	326	D23M3...		334	DSIS05063	21.752.0	355
R41M4...		313	KR080V	25.128.3	326	D23M4...		334	DSIS080100	21.753.0	355
R42M1...		313	KR100V	25.129.3	326	GD016	22.100.2	342	DSIS125	21.754.0	355
R42M2...		313	KP032PV	25.034.3	326	GD020	22.101.2	342	DSIS160200	21.755.0	355
R42M3...		313	KP040PV	25.035.3	326	GD025	22.102.2	342	TS8T10	26.010.0	356
R42M4...		313	KP050PV	25.036.3	326	GD032	22.103.2	342	TS12T16	26.011.0	356
R43M1...		313	KP063PV	25.037.3	326	GD040	22.104.2	342	TST20	26.012.0	356
R43M2...		313	KP080PV	25.038.3	326	GD050	22.105.2	342	TS25T32	26.013.0	356
R43M3...		313	KP100PV	25.039.3	326	GD063	22.106.2	342	TST40	26.014.0	356
R43M4...		313	KR032PV	25.134.3	326	GD080	22.107.2	342	TS50T63	26.015.0	356
GP032	25.103.2	317	KR040PV	25.135.3	326	GD100	22.108.2	342	TS80T100	26.016.0	356
GP040	25.104.2	317	KR050PV	25.136.3	326	GD16V	22.120.2	342	TST125	26.017.0	356
GP050	25.105.2	317	KR063PV	25.137.3	326	GD020V	22.121.2	342	TS160T200	26.018.0	356
GP063	25.106.2	317	KR080PV	25.138.3	326	GD025V	22.122.2	342	SN12D16	26.019.0	357
GP080	25.107.2	317	KR100PV	25.139.3	326	GD032V	22.123.2	342	SND20	26.020.0	357
GP100	25.108.2	317		000.523.7	327	GD040V	22.124.2	342	SN25D32	26.021.0	357
GP032P	25.113.2	317		000.524.7	327	GD050V	22.125.2	342	SND40	26.022.0	357
GP040P	25.114.2	317		000.525.7	327	GD063V	22.126.2	342	SN50D63	26.023.0	357
GP050P	25.115.2	317		000.526.7	327	GD080V	22.127.2	342	SN80D100	26.024.0	357
GP063P	25.116.2	317		000.527.7	327	GD100V	22.128.2	342	UB012C050	27.117.2	360
GP080P	25.117.2	317		000.528.7	327	GD016P	22.110.2	342	UB012C100	27.118.2	360
GP100P	25.118.2	317	CFUN032	26.501.2	330	GD020P	22.111.2	342	UB012C160	27.119.2	360
GP032V	25.123.2	317	CFUN040	26.502.2	330	GD025P	22.112.2	342	UB012C200	27.120.2	360
GP040V	25.124.2	317	CFUN050	26.503.2	330	GD032P	22.113.2	342	UB012C250	27.121.2	360
GP050V	25.125.2	317	CFUN063	26.504.2	330	GD040P	22.114.2	342	UB020C050	27.122.2	360
GP063V	25.126.2	317	CFUN080	26.505.2	330	GD050P	22.115.2	342	UB020C100	27.123.2	360
GP080V	25.127.2	317	CFUN100	26.506.2	330	GD063P	22.116.2	342	UB020C160	27.124.2	360
GP100V	25.128.2	317	CFKN032	26.510.2	330	GD080P	22.117.2	342	UB020C200	27.125.2	360
GP032PV	25.133.2	317	CFKN040	26.511.2	330	GD100P	22.118.2	342	UB020C250	27.126.2	360
GP040PV	25.134.2	317	CFKN050	26.512.2	330	GD016PV	22.130.2	342	UB025C050	27.198.2	360
GP050PV	25.135.2	317	CFKN063	26.513.2	330	GD020PV	22.131.2	342	UB025C100	27.199.2	360
GP063PV	25.136.2	317	CFKN080	26.514.2	330	GD025PV	22.132.2	342	UB025C160	27.200.2	360
GP080PV	25.137.2	317	CFKN100	26.515.2	330	GD032PV	22.133.2	342	UB025C200	27.201.2	360

INDEX

indice alfanumerico ordinato per pagina

product reference directory - ordered by catalogue page



sigla part number	codice code	pagina page	sigla part number	codice code	pagina page	sigla part number	codice code	pagina page	sigla part number	codice code	pagina page
UB025C250	27.202.2	360	HB012C200	27.062.2	362	HB032C500	27.076.2	363		26.195.0	369
UB032C050	27.127.2	361	HB012C250	27.063.2	362	HB040C050	27.077.2	363		26.196.0	369
UB032C100	27.128.2	361	HB020C050	27.064.2	362	HB040C100	27.078.2	363	FIL 2-25-S	16.002.3	376
UB032C150	27.129.2	361	HB020C100	27.065.2	362	HB040C150	27.079.2	363	FIL 2-05-S	16.016.3	376
UB032C200	27.130.2	361	HB020C160	27.066.2	362	HB040C200	27.080.2	363	FIL 3-30-S	16.006.3	378
UB032C250	27.131.2	361	HB020C200	27.067.2	362	HB040C250	27.081.2	363	FIL 3-30-A	16.036.3	378
UB032C300	27.132.2	361	HB020C250	27.068.2	362	HB040C300	27.082.2	363	FIL 3-05-S	16.017.3	378
UB032C400	27.133.2	361	HB025C050	27.208.2	362	HB040C400	27.083.2	363	FIL 4-30-S	16.010.3	380
UB032C500	27.134.2	361	HB025C100	27.209.2	362	HB040C500	27.084.2	363	FIL 4-30-A	16.023.3	380
UB040C050	27.135.2	361	HB025C160	27.210.2	362	HB050C050	27.085.2	363	FIL 4-05-S	16.018.3	380
UB040C100	27.136.2	361	HB025C200	27.211.2	362	HB050C100	27.086.2	363	FIL 6-30-S	16.040.3	382
UB040C150	27.137.2	361	HB025C250	27.212.2	362	HB050C150	27.087.2	363	FIL 6-30-A	16.037.3	382
UB040C200	27.138.2	361	HS032C050	27.011.0	363	HB050C200	27.088.2	363	FIL 6-05-S	16.038.3	382
UB040C250	27.139.2	361	HS032C100	27.012.0	363	HB050C250	27.089.2	363	MFIL 2-S	16.024.3	384
UB040C300	27.140.2	361	HS032C150	27.013.0	363	HB050C300	27.090.2	363	MFIL 3-S	16.025.3	384
UB040C400	27.141.2	361	HS032C200	27.014.0	363	HB050C400	27.091.2	363	MFIL 4-S	16.026.3	384
UB040C500	27.142.2	361	HS032C250	27.015.0	363	HB050C500	27.092.2	363	CFIL 2-S	16.056.3	386
UB050C050	27.143.2	361	HS032C300	27.016.0	363	HB063C050	27.093.2	363	CFIL 3-S	16.057.3	386
UB050C100	27.144.2	361	HS032C400	27.017.0	363	HB063C100	27.094.2	363	CFIL 4-S	16.059.3	386
UB050C150	27.145.2	361	HS032C500	27.018.0	363	HB063C150	27.095.2	363	MREG 1-08	16.018.4	388
UB050C200	27.146.2	361	HS040C050	27.019.0	363	HB063C200	27.096.2	363	MREG 2-08	16.011.4	388
UB050C250	27.147.2	361	HS040C100	27.020.0	363	HB063C250	27.097.2	363	MREG 2-04	16.016.4	388
UB050C300	27.148.2	361	HS040C150	27.021.0	363	HB063C300	27.098.2	363	REG 2-08	16.001.3	390
UB050C400	27.149.2	361	HS040C200	27.022.0	363	HB063C400	27.099.2	363	REG 2-04	16.015.3	390
UB050C500	27.150.2	361	HS040C250	27.023.0	363	HB063C500	27.100.2	363	REG 2-08-SR	16.032.3	392
UB063C050	27.151.2	361	HS040C300	27.024.0	363	HB080C050	27.230.2	363	REG 3-08	16.005.3	394
UB063C100	27.152.2	361	HS040C400	27.025.0	363	HB080C100	27.231.2	363	REG 4-08	16.009.3	396
UB063C150	27.153.2	361	HS040C500	27.026.0	363	HB080C150	27.232.2	363	REG 6-10	16.043.3	398
UB063C200	27.154.2	361	HS050C050	27.027.0	363	HB080C200	27.104.2	363	LUB 2-00	16.003.3	400
UB063C250	27.155.2	361	HS050C100	27.028.0	363	HB080C250	27.105.2	363	LUB 3-00	16.007.3	402
UB063C300	27.156.2	361	HS050C150	27.029.0	363	HB080C300	27.106.2	363	LUB 4-00	16.011.3	404
UB063C400	27.180.2	361	HS050C200	27.030.0	363	HB080C400	27.107.2	363	LUB 6-00	16.044.3	406
UB063C500	27.181.2	361	HS050C250	27.031.0	363	HB080C500	27.108.2	363	FR 2-08-25-S	16.004.3	408
UB080C050	27.182.2	361	HS050C300	27.032.0	363	HB100C050	27.109.2	363	FR 2-08-05-S	16.020.3	408
UB080C100	27.183.2	361	HS050C400	27.033.0	363	HB100C100	27.110.2	363	FR 3-08-30-S	16.008.3	410
UB080C150	27.184.2	361	HS050C500	27.034.0	363	HB100C150	27.111.2	363	FR 3-08-05-S	16.021.3	410
UB080C200	27.185.2	361	HS063C050	27.035.0	363	HB100C200	27.112.2	363	FR 4-08-30-S	16.012.3	412
UB080C250	27.186.2	361	HS063C100	27.036.0	363	HB100C250	27.113.2	363	FR 4-08-05-S	16.022.3	412
UB080C300	27.187.2	361	HS063C150	27.037.0	363	HB100C300	27.114.2	363	FR 6-10-30-S	16.045.3	414
UB080C400	27.188.2	361	HS063C200	27.038.0	363	HB100C400	27.115.2	363	FR 6-10-05-S	16.039.3	414
UB080C500	27.189.2	361	HS063C250	27.039.0	363	HB100C500	27.116.2	363	FR+L 2-08-25-S	16.001.4	416
UB100C050	27.190.2	361	HS063C300	27.040.0	363	RS1-A	RS1/A	364	FR+L 3-08-30-S	16.003.4	418
UB100C100	27.191.2	361	HS063C400	27.041.0	363	RS1-A 5MT	RS1/A 5MT	364	FR+L 4-08-30-S	16.007.4	420
UB100C150	27.192.2	361	HS063C500	27.042.0	363	RS2-A	RS2/A	364	FR+L 6-10-30-S	16.024.4	422
UB100C200	27.193.2	361	HS080C050	27.043.0	363	RS3-A	RS3/A	364	FRL 2-08-25-S	16.002.4	424
UB100C250	27.194.2	361	HS080C100	27.044.0	363	RS4-A	RS4/A	364	FRL 3-08-30-S	16.004.4	426
UB100C300	27.195.2	361	HS080C150	27.045.0	363	RS5-C	RS5/C	364	FRL 4-08-30-S	16.008.4	428
UB100C400	27.196.2	361	HS080C200	27.046.0	363	RS6-3F	RS6/3F	365	FRL 6-10-30-S	16.025.4	430
UB100C500	27.197.2	361	HS080C250	27.047.0	363	RS7-3F	RS7/3F	365	AVP 2-00	10.004.3	432
HS012C050	27.001.0	362	HS080C300	27.048.0	363	SH1-P	SH1/P	365	SCR 3-P	16.029.4	434
HS012C100	27.002.0	362	HS080C400	27.049.0	363	SH2-P	SH2/P	365	SCR 3-E	16.035.3	434
HS012C160	27.003.0	362	HS080C500	27.050.0	363		26.164.0	366	AVP 3-00	16.030.4	435
HS012C200	27.004.0	362	HS100C050	27.051.0	363		26.165.0	366	SCR 4-P	16.013.4	436
HS012C250	27.005.0	362	HS100C100	27.052.0	363		26.166.0	366	SCR 4-E	16.019.3	436
HS020C050	27.006.0	362	HS100C150	27.053.0	363		26.167.0	366	AVP 4-00	16.012.4	438
HS020C100	27.007.0	362	HS100C200	27.054.0	363		26.147.0	368	SR-M3	16.013.3	440
HS020C160	27.008.0	362	HS100C250	27.055.0	363		26.219.2	368	SR-M4	16.014.3	441
HS020C200	27.009.0	362	HS100C300	27.056.0	363		26.039.0	368	SR-M6	16.046.3	442
HS020C250	27.010.0	362	HS100C400	27.057.0	363		26.040.0	368	RPE 3 V NC	16.050.3	444
HS025C050	27.203.0	362	HS100C500	27.058.0	363		26.041.0	368	RPE 3 V NA	16.051.3	444
HS025C100	27.204.0	362	HB032C050	27.069.2	363		26.042.0	368	RPE 3 A NC	16.052.3	444
HS025C160	27.205.0	362	HB032C100	27.070.2	363		26.229.0	368	RPE 4 V NC	16.053.3	447
HS025C200	27.206.0	362	HB032C150	27.071.2	363		26.230.0	368	RPE 4 V NA	16.054.3	447
HS025C250	27.207.0	362	HB032C200	27.072.2	363		26.231.0	368	RPE 4 A NC	16.055.3	447
HB012C050	27.059.2	362	HB032C250	27.073.2	363		26.232.0	368	PAI 2-00	16.010.2	452
HB012C100	27.060.2	362	HB032C300	27.074.2	363		26.194.0	369	PAI 3-00	16.041.0	452
HB012C160	27.061.2	362	HB032C400	27.075.2	363		26.145.0	369	PAI 4-00	16.042.0	453

indice alfanumerico ordinato per sigla

product reference directory - ordered by part number



sigla part number	codice code	pagina page	sigla part number	codice code	pagina page	sigla part number	codice code	pagina page	sigla part number	codice code	pagina page
152 CC	00.096.4	180	252 EE AS	02.074.3	195	314 MV	08.116.4	19	322 CC	01.025.4	81
152 CCD	00.094.4	180	252 EFP	02.072.3	194	314 MV UL	08.158.4	21	322 CC SUP	01.036.4	82
152 CFP	00.173.4	180	252 MC	02.050.4	193	315 MA	08.045.4	22	322 CCD	01.024.4	82
152 EE	00.114.4	182	252 ME	02.070.3	194	315 MA UL	08.151.4	24	322 CE	01.029.3	114
152 EE AS	00.065.4	182	252 ME AS	02.073.3	194	315 MB	08.046.4	22	322 CFP	01.021.4	82
152 EFP	06.001.4	181	253A CC	02.055.4	193	315 MB UL	08.175.4	25	322 CL90	01.082.4	55
152 MC	00.095.4	180	253A EE	02.076.3	195	315 MGG	08.253.4	28	322 CT	01.041.4	58
152 ME	00.112.4	181	253A EE AS	02.079.4	195	315 MGG UL	08.257.4	28	322 CTT	01.078.4	58
152 ME AS	00.064.4	181	253C CC	02.054.4	193	315 MGN	08.255.4	28	322 EE	01.012.3	116
153A CC	00.102.4	180	253C EE	02.075.3	195	315 MGN UL	08.259.4	28	322 EE AS	01.050.3	118
153A EE	00.117.4	182	253C EE AS	02.078.3	195	315 MGR	08.252.4	28	322 EED	01.039.3	116
153A EE AS	00.067.4	182	253P CC	02.056.4	193	315 MGR UL	08.256.4	28	322 EFP	01.049.3	117
153C CC	00.101.4	180	253P EE	02.077.3	195	315 MG V	08.254.4	28	322 LL	01.049.4	60
153C EE	00.116.4	182	253P EE AS	02.080.4	195	315 MG V UL	08.258.4	28	322 LL90	01.055.4	54
153C EE AS	00.066.4	182	304 MA	08.030.4	17	315 MR	08.047.4	23	322 MC	01.022.4	80
153P CC	00.103.4	180	304 MA UL	08.050.4	19	315 MR UL	08.188.4	25	322 MC SUP	01.037.4	80
153P EE	00.118.4	182	304 MB	08.031.4	17	315 MS	08.048.4	23	322 MCA	01.023.4	80
153P EE AS	00.113.4	182	304 MB UL	08.051.4	20	315 MS UL	08.152.4	26	322 MCS	01.083.4	89
2.304 MB	08.085.4	29	304 MGG	08.213.4	27	315 MV	08.153.4	24	322 ME	01.011.3	114
2.304 MB CU	08.086.4	31	304 MGG UL	08.217.4	27	315 MV UL	08.190.4	26	322 ME AS	01.018.3	115
2.304 MB UL	08.067.4	30	304 MGN	08.215.4	27	321 2P	00.133.4	35	322 MEA	01.017.3	114
2.305 MB	08.146.4	29	304 MGN UL	08.219.4	27	321 2PS	00.134.4	38	322 ML90	01.054.4	53
2.305 MB UL	08.194.4	30	304 MGR	08.212.4	27	321 BB90	00.141.4	63	322 MT	01.066.4	57
2.314 MB	08.089.4	29	304 MGR UL	08.216.4	27	321 CC	00.025.4	77	322 ORM	01.009.4	84
2.314 MB UL	08.068.4	30	304 MG V	08.214.4	27	321 CCD	00.024.4	77	322 TT	01.067.4	57
2.315 MB	08.192.4	29	304 MG V UL	08.218.4	27	321 CE	00.032.3	104	324 CC	02.004.4	130
2.315 MB UL	08.195.4	30	304 MR	08.032.4	18	321 CFP	00.021.4	77	324 CCD	02.005.4	130
204 MA	08.104.4	17	304 MR UL	08.052.4	20	321 CL90	00.139.4	45	324 CFP	02.003.4	130
204 MA UL	08.172.4	19	304 MS	08.033.4	18	321 CP	00.135.4	36	324 EE	02.005.3	135
204 MB	08.105.4	17	304 MS UL	08.053.4	21	321 CT	00.110.4	48	324 EE AS	02.006.3	135
204 MB UL	08.130.4	20	304 MV	08.034.4	19	321 CTT	00.004.4	48	324 EED	02.007.3	135
204 MGG	08.229.4	27	304 MV UL	08.054.4	21	321 EE	00.016.3	106	324 EFP	02.004.3	134
204 MGG UL	08.233.4	27	305 LL	03.011.4	31	321 EE AS	00.066.3	108	324 MC	02.001.4	130
204 MGN	08.231.4	27	305 MA	08.040.4	22	321 EE90 L	00.060.3	112	324 MCA	02.002.4	130
204 MGN UL	08.235.4	27	305 MA UL	08.055.4	24	321 EE90 S	00.006.3	112	324 ME	02.001.3	134
204 MGR	08.228.4	27	305 MB	08.041.4	22	321 EED	00.050.3	106	324 ME AS	02.003.3	134
204 MGR UL	08.232.4	27	305 MB UL	08.056.4	25	321 EFP	00.065.3	107	324 MEA	02.002.3	134
204 MG V	08.230.4	27	305 MGG	08.221.4	28	321 LL	00.050.4	52	382 CC	01.014.4	175
204 MG V UL	08.234.4	27	305 MGG UL	08.225.4	28	321 LL90	00.053.4	44	382 EE	01.003.3	176
204 MR	08.111.4	18	305 MGN	08.223.4	28	321 MB	00.072.4	61	382 MC	01.013.4	175
204 MR UL	08.196.4	20	305 MGN UL	08.227.4	28	321 MB90	00.070.4	62	382 ME	01.041.3	176
204 MS	08.117.4	18	305 MGR	08.220.4	28	321 MBA	00.061.4	61	431 MGG	05.143.4	74
204 MS UL	08.160.4	21	305 MGR UL	08.224.4	28	321 MBA90	00.041.4	62	431 MGN	05.145.4	74
204 MV	08.125.4	19	305 MG V	08.222.4	28	321 MC	00.022.4	76	431 MGR	05.142.4	74
204 MV UL	08.149.4	21	305 MG V UL	08.226.4	28	321 MCA	00.023.4	76	431 MG V	05.144.4	74
205 MA	08.141.4	22	305 MR	08.042.4	23	321 MCQ	00.010.4	88	431 MP	05.136.4	71
205 MA UL	08.169.4	24	305 MR UL	08.057.4	25	321 MCS	00.015.4	88	431 MR	05.138.4	72
205 MB	08.157.4	22	305 MS	08.043.4	23	321 ME	00.015.3	104	431 MRL	05.140.4	73
205 MB UL	08.187.4	25	305 MS UL	08.058.4	26	321 ME AS	00.033.3	105	451 MGG	05.147.4	74
205 MGG	08.237.4	28	305 MV	08.044.4	24	321 ME90 L	00.059.3	110	451 MGN	05.149.4	74
205 MGG UL	08.241.4	28	305 MV UL	08.059.4	26	321 ME90 S	00.005.3	110	451 MGR	05.146.4	74
205 MGN	08.239.4	28	314 MA	08.035.4	17	321 MEA	00.010.3	104	451 MG V	05.148.4	74
205 MGN UL	08.243.4	28	314 MA UL	08.060.4	19	321 ML90	00.052.4	43	451 MP	05.137.4	71
205 MGR	08.236.4	28	314 MB	08.036.4	17	321 MN	00.089.4	41	451 MR	05.139.4	72
205 MGR UL	08.240.4	28	314 MB UL	08.061.4	20	321 MNA	00.090.4	41	451 MRL	05.141.4	73
205 MG V	08.238.4	28	314 MGG	08.245.4	27	321 MP	00.077.4	35	504 MB	08.064.4	29
205 MG V UL	08.242.4	28	314 MGG UL	08.249.4	27	321 MPS	00.079.4	37	504 MB CU	08.087.4	31
205 MR	08.173.4	23	314 MGN	08.247.4	27	321 MP SA	00.080.4	37	504 MB UL	08.065.4	30
205 MR UL	08.119.4	25	314 MGN UL	08.251.4	27	321 MR	00.082.4	38	505 MB	08.094.4	29
205 MS	08.185.4	23	314 MGR	08.244.4	27	321 MRS	00.086.4	40	505 MB UL	08.193.4	30
205 MS UL	08.189.4	26	314 MGR UL	08.248.4	27	321 MRSA	00.087.4	40	521 2P	00.036.4	36
205 MV	08.186.4	24	314 MG V	08.246.4	27	321 MRU	00.084.4	39	521 2PS	00.019.4	38
205 MV UL	08.191.4	26	314 MG V UL	08.250.4	27	321 MT	00.075.4	47	521 BB90	00.138.4	63
252 CC	02.051.4	193	314 MR	08.037.4	18	321 TT	00.068.4	47	521 CC	00.028.4	78
252 CCD	02.052.4	193	314 MR UL	08.062.4	20	322 2AND	01.012.4	85	521 CCD	00.030.4	78
252 CFP	02.053.4	193	314 MS	08.038.4	18	322 2OR	01.011.4	85	521 CE	00.035.3	105
252 EE	02.071.3	195	314 MS UL	08.063.4	21	322 ANDM	01.010.4	84	521 CFP	00.029.4	78

indice alfanumerico ordinato per sigla

product reference directory - ordered by part number



sigla part number	codice code	pagina page	sigla part number	codice code	pagina page	sigla part number	codice code	pagina page	sigla part number	codice code	pagina page
521 CL90	00.140.4	45	522 ME AS	01.019.3	116	731 ME 04	05.014.4	161	851 EE 02	05.082.4	146
521 CP	00.136.4	36	522 ML90	01.056.4	53	731 ME AS 00	05.020.4	162	851 EE 03	05.083.4	146
521 CT	00.111.4	49	522 MT	01.068.4	57	731 ME AS 01	05.021.4	162	851 EE 04	05.084.4	146
521 CTT	00.005.4	49	522 ORM	01.001.4	86	731 ME AS 02	05.022.4	162	851 EE AS 00	05.105.4	146
521 EE	00.014.3	107	522 TT	01.069.4	58	731 ME AS 03	05.023.4	162	851 EE AS 01	05.106.4	146
521 EE AS	00.067.3	108	5223A CC	01.035.4	79	731 ME AS 04	05.024.4	162	851 EE AS 02	05.107.4	146
521 EE90 L	00.062.3	113	5223A EE	01.022.3	119	731 MEA 00	05.015.4	161	851 EE AS 03	05.108.4	146
521 EE90 S	00.009.3	113	5223A EE AS	01.025.3	119	731 MEA 01	05.016.4	161	851 EE AS 04	05.109.4	146
521 EED	00.049.3	107	5223A LL90	01.060.4	56	731 MEA 02	05.017.4	161	851 EFP 00	05.120.4	145
521 EFP	00.063.3	108	5223A ML90	01.062.4	56	731 MEA 03	05.018.4	161	851 EFP 01	05.121.4	145
521 LL	00.051.4	52	5223C CC	01.034.4	79	731 MEA 04	05.019.4	161	851 EFP 02	05.122.4	145
521 LL90	00.055.4	44	5223C EE	01.021.3	119	751 CC	05.006.4	156	851 EFP 03	05.123.4	145
521 MB	00.073.4	61	5223C EE AS	01.024.3	119	751 CCD	05.007.4	157	851 EFP 04	05.124.4	145
521 MB90	00.071.4	62	5223C LL90	01.059.4	56	751 CFP	05.008.4	158	851 MC	05.077.4	140
521 MC	00.027.4	76	5223C ML90	01.061.4	56	751 EE 00	05.050.4	164	851 ME 00	05.072.4	144
521 MCQ	00.011.4	88	5223P CC	01.073.4	79	751 EE 01	05.051.4	164	851 ME 01	05.073.4	144
521 MCS	00.016.4	89	5223P EE	01.023.3	119	751 EE 02	05.052.4	164	851 ME 02	05.074.4	144
521 ME	00.013.3	105	5223P EE AS	01.026.3	119	751 EE 03	05.053.4	164	851 ME 03	05.075.4	144
521 ME AS	00.034.3	106	5223P LL90	01.058.4	56	751 EE 04	05.054.4	164	851 ME 04	05.076.4	144
521 ME90 L	00.061.3	111	5223P ML90	01.063.4	56	751 EE AS 00	05.055.4	165	851 ME AS 00	05.100.4	144
521 ME90 S	00.007.3	111	524 CC	02.008.4	131	751 EE AS 01	05.056.4	165	851 ME AS 01	05.101.4	144
521 ML90	00.054.4	43	524 CCD	02.009.4	131	751 EE AS 02	05.057.4	165	851 ME AS 02	05.102.4	144
521 MN	00.091.4	41	524 CFP	02.007.4	131	751 EE AS 03	05.058.4	165	851 ME AS 03	05.103.4	144
521 MP	00.078.4	35	524 EE	02.011.3	137	751 EE AS 04	05.059.4	165	851 ME AS 04	05.104.4	144
521 MPS	00.081.4	37	524 EE AS	02.012.3	137	751 EFP 00	05.095.4	163	8513A CC	05.151.4	142
521 MR	00.083.4	39	524 EED	02.013.3	137	751 EFP 01	05.096.4	163	8513A EE 00	05.115.4	147
521 MRS	00.088.4	40	524 EFP	02.010.3	136	751 EFP 02	05.097.4	163	8513A EE 01	05.116.4	147
521 MRU	00.085.4	39	524 MC	02.006.4	131	751 EFP 03	05.098.4	163	8513A EE 02	05.117.4	147
521 MT	00.076.4	47	524 ME	02.008.3	136	751 EFP 04	05.099.4	163	8513A EE 03	05.118.4	147
521 TT	00.069.4	48	524 ME AS	02.009.3	136	751 MC	05.005.4	155	8513A EE 04	05.119.4	147
5213A CC	00.032.4	79	5243A CC	02.011.4	131	751 ME 00	05.040.4	161	8513A EE AS 00	05.130.4	147
5213A EE	00.037.3	109	5243A EE	02.015.3	137	751 ME 01	05.041.4	161	8513A EE AS 01	05.131.4	147
5213A EE AS	00.040.3	109	5243A EE AS	02.018.3	137	751 ME 02	05.042.4	161	8513A EE AS 02	05.132.4	147
5213A LL90	00.059.4	46	5243C CC	02.010.4	131	751 ME 03	05.043.4	161	8513A EE AS 03	05.133.4	147
5213A ML	00.151.4	50	5243C EE	02.014.3	137	751 ME 04	05.044.4	161	8513A EE AS 04	05.134.4	147
5213A ML90	00.058.4	46	5243C EE AS	02.017.3	137	751 ME AS 00	05.045.4	162	8513C CC	05.150.4	142
5213C CC	00.031.4	79	5243P CC	02.012.4	131	751 ME AS 01	05.046.4	162	8513C EE 00	05.110.4	147
5213C EE	00.036.3	109	5243P EE	02.016.3	137	751 ME AS 02	05.047.4	162	8513C EE 01	05.111.4	147
5213C EE AS	00.039.3	109	5243P EE AS	02.019.3	137	751 ME AS 03	05.048.4	162	8513C EE 02	05.112.4	147
5213C LL90	00.057.4	46	582 CC	01.015.4	175	751 ME AS 04	05.049.4	162	8513C EE 03	05.113.4	147
5213C ML90	00.056.4	46	582 EE	01.038.3	176	7513A CC	05.153.4	159	8513C EE 04	05.114.4	147
5213P CC	00.043.4	79	582 MC	01.008.4	175	7513A EE 00	05.065.4	166	8513C EE AS 00	05.125.4	147
5213P EE	00.038.3	109	582 ME	01.037.3	176	7513A EE 01	05.066.4	166	8513C EE AS 01	05.126.4	147
5213P EE AS	00.041.3	109	731 CC	05.002.4	156	7513A EE 02	05.067.4	166	8513C EE AS 02	05.127.4	147
5213P LL90	00.060.4	46	731 CCD	05.003.4	157	7513A EE 03	05.068.4	166	8513C EE AS 03	05.128.4	147
5213P ML90	00.042.4	46	731 CFP	05.004.4	158	7513A EE 04	05.069.4	166	8513C EE AS 04	05.129.4	147
522 2AND	01.006.4	87	731 EE 00	05.025.4	164	7513A EE AS 00	05.090.4	166	AKS 3	16.007.2	456
522 2OR	01.005.4	87	731 EE 01	05.026.4	164	7513A EE AS 01	05.091.4	166	AKS 4-6	16.029.0	456
522 ANDM	01.002.4	86	731 EE 02	05.027.4	164	7513A EE AS 02	05.092.4	166	AVP 2-00	10.004.3	432
522 CC	01.028.4	83	731 EE 03	05.028.4	164	7513A EE AS 03	05.093.4	166	AVP 3-00	16.030.4	435
522 CC SUP	01.070.4	84	731 EE 04	05.029.4	164	7513A EE AS 04	05.094.4	166	AVP 4-00	16.012.4	438
522 CCD	01.030.4	83	731 EE AS 00	05.030.4	165	7513C CC	05.152.4	159	AZ-CRS1	18.001.0	224
522 CE	01.020.3	115	731 EE AS 01	05.031.4	165	7513C EE 00	05.060.4	166	AZ-CRS2	18.002.0	224
522 CFP	01.029.4	83	731 EE AS 02	05.032.4	165	7513C EE 01	05.061.4	166	AZ-CRS3	18.003.0	224
522 CL90	01.065.4	55	731 EE AS 03	05.033.4	165	7513C EE 02	05.062.4	166	AZ-CRS4	18.004.0	224
522 CT	01.042.4	59	731 EE AS 04	05.034.4	165	7513C EE 03	05.063.4	166	AZ-SC1	AU.040.0	223
522 CTT	01.079.4	59	731 EFP 00	05.035.4	163	7513C EE 04	05.064.4	166	AZ-SC2	AU.044.0	223
522 EE	01.010.3	117	731 EFP 01	05.036.4	163	7513C EE AS 00	05.085.4	166	AZ-SC3	AU.053.0	223
522 EE AS	01.052.3	118	731 EFP 02	05.037.4	163	7513C EE AS 01	05.086.4	166	AZ-SC4	AU.074.0	223
522 EED	01.040.3	117	731 EFP 03	05.038.4	163	7513C EE AS 02	05.087.4	166	AZ-SC5	AU.073.0	223
522 EFP	01.045.3	118	731 EFP 04	05.039.4	163	7513C EE AS 03	05.088.4	166	AZ-SE1	AU.043.0	222
522 LL	01.050.4	60	731 MC	05.001.4	155	7513C EE AS 04	05.089.4	166	AZ-SE2	AU.047.0	222
522 LL90	01.057.4	54	731 MCA	05.071.4	155	851 CC	05.078.4	140	AZ-SE3	AU.054.0	222
522 MC	01.027.4	81	731 ME 00	05.010.4	161	851 CCD	05.079.4	141	AZ-SE4	AU.072.0	222
522 MC SUP	01.074.4	81	731 ME 01	05.011.4	161	851 CFP	05.135.4	141	AZ-SE5	AU.071.0	222
522 MCS	01.004.4	89	731 ME 02	05.012.4	161	851 EE 00	05.080.4	146	AZ-SEP1	AU.041.0	223
522 ME	01.009.3	115	731 ME 03	05.013.4	161	851 EE 01	05.081.4	146	AZ-SEP2	AU.045.0	223

INDEX

indice alfanumerico ordinato per sigla

product reference directory - ordered by part number



sigla part number	codice code	pagina page	sigla part number	codice code	pagina page	sigla part number	codice code	pagina page	sigla part number	codice code	pagina page
AZ-SEP3	AU.051.0	223	CIN063	26.091.2N	306	D23M3...		334	FR 6N-10-30-S	16.120.0	470
AZ-SEP4	AU.076.0	223	CIN080	26.092.2N	306	D23M4...		334	FR+L 2-08-25-S	16.001.4	416
AZ-SEP5	AU.075.0	223	CIN100	26.093.2N	306	DC751	05.026.2	168	FR+L 3-08-30-S	16.003.4	418
AZ-SFE1	AU.042.0	222	CIN125	26.100.2N	306	DC851	05.033.2	151	FR+L 4-08-30-S	16.007.4	420
AZ-SFE2	AU.046.0	222	CMIS032	26.019.2N	302	DCCB 16/32 (M5)	26.156.0T	343	FR+L 6-10-30-S	16.024.4	422
AZ-SFE3	AU.052.0	222	CMIS040	26.020.2N	302	DCCB 32/100 (M6)	26.157.0T	343	FR+L 6N-10-30-S	16.060.4	472
AZ-SFE4	AU.058.0	222	CMIS050	26.021.2N	302	DD751	05.028.2	170	FR12C16	26.120.2	354
AZ-SFE5	AU.057.0	222	CMIS063	26.022.2N	302	DF1	00.307.0	189	FR160C200	26.127.2	354
AZ-SPL2	AU.048.0	222	CMIS080	26.023.2N	302	DF851	05.102.2	152	FR25C32	26.122.2	354
AZ-SPL3	AU.055.0	222	CMIS100	26.024.2N	302	DP 2005	03.009.4	260	FR50C63	26.124.2	354
AZ-SPL4	AU.060.0	222	CMIS125	26.025.2N	302	DP 2010 E	03.020.4	258	FR80C100	26.125.2	354
AZ-SPL5	AU.059.0	222	CMIS160	26.026.2N	302	DP 2018 F	03.003.4	259	FR8C10	26.119.2	354
BM012	27.157.0	352	CMIS200	26.027.2N	302	DR751	05.027.2	168	FRC125	26.126.2	354
BM020	27.158.0	352	CMKS032	26.028.2N	302	DR851	05.034.2	151	FRC20	26.121.2	354
BM025	27.159.0	352	CMKS040	26.029.2N	302	DSIS032	21.750.0	355	FRC40	26.123.2	354
BM032	27.160.0	352	CMKS050	26.030.2N	302	DSIS040	21.751.0	355	FRL 2-08-25-S	16.002.4	424
BM040	27.161.0	352	CMKS063	26.031.2N	302	DSIS05063	21.752.0	355	FRL 3-08-30-S	16.004.4	426
BM050	27.162.0	352	CMKS080	26.032.2N	302	DSIS080100	21.753.0	355	FRL 4-08-30-S	16.008.4	428
BM063	27.163.0	352	CMKS100	26.033.2N	302	DSIS125	21.754.0	355	FRL 6-10-30-S	16.025.4	430
BM080	27.164.0	352	CMKS125	26.034.2N	302	DSIS160200	21.755.0	355	FRL 6N-10-30-S	16.061.4	474
BM100	27.165.0	352	CMKS160	26.035.2N	302	DSMC12-16	26.197.2	355	GD016	22.100.2	342
BM125	27.166.0	352	CMKS200	26.036.2N	302	DSMC20	26.198.2	355	GD016P	22.110.2	342
BM751	05.025.2	168	CMSS032	26.079.2N	301	DSMC8-10	26.196.2	355	GD016PV	22.130.2	342
BM851	05.030.2	149	CMSS040	26.080.2N	301	FIL 2-05-S	16.016.3	376	GD016V	22.120.2	342
BS851	05.029.1	149	CMSS050	26.081.2N	301	FIL 2-25-S	16.002.3	376	GD020	22.101.2	342
CCMC08-10	26.107.2N	275	CMSS063	26.082.2N	301	FIL 3-05-S	16.017.3	378	GD020P	22.111.2	342
CCMC12-16	26.108.2N	275	CMSS080	26.083.2N	301	FIL 3-30-A	16.036.3	378	GD020PV	22.131.2	342
CCMC20-25	26.109.2N	275	CMSS100	26.084.2N	301	FIL 3-30-S	16.006.3	378	GD020V	22.121.2	342
CCR032	26.116.2	285	CMSS125	26.085.2N	301	FIL 4-05-S	16.018.3	380	GD025	22.102.2	342
CCR040	26.117.2	285	CMSS160	26.086.2N	301	FIL 4-30-A	16.023.3	380	GD025P	22.112.2	342
CCR050	26.118.2	285	CMSS200	26.087.2N	301	FIL 4-30-S	16.010.3	380	GD025PV	22.132.2	342
CFIL 2-S	16.056.3	386	COIS032	26.052.2N	309	FIL 6-05-S	16.038.3	382	GD025V	22.122.2	342
CFIL 3-S	16.057.3	386	COIS040	26.053.2N	309	FIL 6-30-A	16.037.3	382	GD032	22.103.2	342
CFIL 4-S	16.059.3	386	COIS050	26.054.2N	309	FIL 6-30-S	16.040.3	382	GD032P	22.113.2	342
CFIS032	26.001.2N	303	COIS063	26.055.2N	309	FIL 6N-05-S	16.117.0	464	GD032PV	22.133.2	342
CFIS040	26.002.2N	303	COIS080	26.056.2N	309	FIL 6N-30-A	16.116.0	464	GD032V	22.123.2	342
CFIS050	26.003.2N	303	COIS100	26.057.2N	309	FIL 6N-30-S	16.115.0	464	GD040	22.104.2	342
CFIS063	26.004.2N	303	COIS125	26.320.2N	309	FLIS032	26.070.2N	304	GD040P	22.114.2	342
CFIS080	26.005.2N	303	COIS160	26.322.2N	309	FLIS040	26.071.2N	304	GD040PV	22.134.2	342
CFIS100	26.006.2N	303	COIS200	26.329.2N	309	FLIS050	26.072.2N	304	GD040V	22.124.2	342
CFIS125	26.007.2N	303	CS731	05.022.2	170	FLIS063	26.073.2N	304	GD050	22.105.2	342
CFIS160	26.008.2N	303	CS751	05.021.2	170	FLIS080	26.074.2N	304	GD050P	22.115.2	342
CFIS200	26.009.2N	303	CS851	05.029.2	152	FLIS100	26.075.2N	304	GD050PV	22.135.2	342
CFKN032	26.510.2	330	CSIS160TI	26.325.2N	308	FLIS125	26.076.2N	304	GD050V	22.125.2	342
CFKN040	26.511.2	330	CSIS200TI	26.326.2N	308	FLIS160	26.077.2N	304	GD063	22.106.2	342
CFKN050	26.512.2	330	D11M1...		334	FLIS200	26.078.2N	304	GD063P	22.116.2	342
CFKN063	26.513.2	330	D11M2...		334	FLMC08-10	26.104.2N	274	GD063PV	22.136.2	342
CFKN080	26.514.2	330	D11M3...		334	FLMC12-16	26.105.2N	274	GD063V	22.126.2	342
CFKN100	26.515.2	330	D11M4...		334	FLMC20-25	26.106.2N	274	GD080	22.107.2	342
CFKS032	26.010.2N	303	D12M1...		334	FLUN032	26.570.2	331	GD080P	22.117.2	342
CFKS040	26.011.2N	303	D12M2...		334	FLUN040	26.571.2	331	GD080PV	22.137.2	342
CFKS050	26.012.2N	303	D12M3...		334	FLUN050	26.572.2	331	GD080V	22.127.2	342
CFKS063	26.013.2N	303	D12M4...		334	FLUN063	26.573.2	331	GD100	22.108.2	342
CFKS080	26.014.2N	303	D13M1...		334	FLUN080	26.574.2	331	GD100P	22.118.2	342
CFKS100	26.015.2N	303	D13M2...		334	FLUN100	26.575.2	331	GD100PV	22.138.2	342
CFKS125	26.016.2N	303	D13M3...		334	FPT032	26.110.2	286	GD100V	22.128.2	342
CFKS160	26.017.2N	303	D13M4...		334	FPT040	26.111.2	286	GPO32	25.103.2	317
CFKS200	26.018.2N	303	D21M1...		334	FPT050	26.112.2	286	GPO32P	25.113.2	317
CFUN032	26.501.2	330	D21M2...		334	FR 2-08-05-S	16.020.3	408	GPO32PV	25.133.2	317
CFUN040	26.502.2	330	D21M3...		334	FR 2-08-25-S	16.004.3	408	GPO32V	25.123.2	317
CFUN050	26.503.2	330	D21M4...		334	FR 3-08-05-S	16.021.3	410	GPO40	25.104.2	317
CFUN063	26.504.2	330	D22M1...		334	FR 3-08-30-S	16.008.3	410	GPO40P	25.114.2	317
CFUN080	26.505.2	330	D22M2...		334	FR 4-08-05-S	16.022.3	412	GPO40PV	25.134.2	317
CFUN100	26.506.2	330	D22M3...		334	FR 4-08-30-S	16.012.3	412	GPO40V	25.124.2	317
CIN032	26.088.2N	306	D22M4...		334	FR 6-10-05-S	16.039.3	414	GPO50	25.105.2	317
CIN040	26.089.2N	306	D23M1...		334	FR 6-10-30-S	16.045.3	414	GPO50P	25.115.2	317
CIN050	26.090.2N	306	D23M2...		334	FR 6N-10-05-S	16.121.0	470	GPO50PV	25.135.2	317

indice alfanumerico ordinato per sigla

product reference directory - ordered by part number



sigla part number	codice code	pagina page	sigla part number	codice code	pagina page	sigla part number	codice code	pagina page	sigla part number	codice code	pagina page
GP050V	25.125.2	317	HB080C100	27.231.2	363	HS080C300	27.048.0	363	KSM032	21.001.3	297
GP063	25.106.2	317	HB080C150	27.232.2	363	HS080C400	27.049.0	363	KSM032P	21.011.3	297
GP063P	25.116.2	317	HB080C200	27.104.2	363	HS080C500	27.050.0	363	KSM032PV	21.031.3	297
GP063PV	25.136.2	317	HB080C250	27.105.2	363	HS100C050	27.051.0	363	KSM032V	21.021.3	297
GP063V	25.126.2	317	HB080C300	27.106.2	363	HS100C100	27.052.0	363	KSM040	21.002.3	297
GP080	25.107.2	317	HB080C400	27.107.2	363	HS100C150	27.053.0	363	KSM040P	21.012.3	297
GP080P	25.117.2	317	HB080C500	27.108.2	363	HS100C200	27.054.0	363	KSM040PV	21.032.3	297
GP080PV	25.137.2	317	HB100C050	27.109.2	363	HS100C250	27.055.0	363	KSM040V	21.022.3	297
GP080V	25.127.2	317	HB100C100	27.110.2	363	HS100C300	27.056.0	363	KSM050	21.003.3	297
GP100	25.108.2	317	HB100C150	27.111.2	363	HS100C400	27.057.0	363	KSM050P	21.013.3	297
GP100P	25.118.2	317	HB100C200	27.112.2	363	HS100C500	27.058.0	363	KSM050PV	21.033.3	297
GP100PV	25.138.2	317	HB100C250	27.113.2	363	J11M2...		345	KSM050V	21.023.3	297
GP100V	25.128.2	317	HB100C300	27.114.2	363	J11M4...		345	KSM063	21.004.3	297
GPM010	26.140.2	272	HB100C400	27.115.2	363	J11M9...		345	KSM063P	21.014.3	297
GPM12-16	26.141.2	272	HB100C500	27.116.2	363	KIT 2-00	16.002.2	455	KSM063PV	21.034.3	297
GPM20-25	26.142.2	272	HS012C050	27.001.0	362	KIT 3-00	16.003.2	455	KSM063V	21.024.3	297
GPT032	26.113.2	285	HS012C100	27.002.0	362	KIT 4-00	16.018.0	455	KSM080	21.005.3	297
GPT040	26.114.2	285	HS012C160	27.003.0	362	KIT 6-00	16.075.0	455	KSM080P	21.015.3	297
GPT050	26.115.2	285	HS012C200	27.004.0	362	KIT 6N-00	16.122.0	455	KSM080PV	21.035.3	297
HB012C050	27.059.2	362	HS012C250	27.005.0	362	KP032	25.004.3	326	KSM080V	21.025.3	297
HB012C100	27.060.2	362	HS020C050	27.006.0	362	KP032P	25.014.3	326	KSM100	21.006.3	297
HB012C160	27.061.2	362	HS020C100	27.007.0	362	KP032PV	25.034.3	326	KSM100P	21.016.3	297
HB012C200	27.062.2	362	HS020C160	27.008.0	362	KP032V	25.024.3	326	KSM100PV	21.036.3	297
HB012C250	27.063.2	362	HS020C200	27.009.0	362	KP040	25.005.3	326	KSM100V	21.026.3	297
HB020C050	27.064.2	362	HS020C250	27.010.0	362	KP040P	25.015.3	326	KSM125	21.007.3	297
HB020C100	27.065.2	362	HS025C050	27.203.0	362	KP040PV	25.035.3	326	KSM125P	21.017.3	297
HB020C160	27.066.2	362	HS025C100	27.204.0	362	KP040V	25.025.3	326	KSM125PV	21.037.3	297
HB020C200	27.067.2	362	HS025C160	27.205.0	362	KP050	25.006.3	326	KSM125V	21.027.3	297
HB020C250	27.068.2	362	HS025C200	27.206.0	362	KP050P	25.016.3	326	KSM160	21.008.3	297
HB025C050	27.208.2	362	HS025C250	27.207.0	362	KP050PV	25.036.3	326	KSM160P	21.018.3	297
HB025C100	27.209.2	362	HS032C050	27.011.0	363	KP050V	25.026.3	326	KSM160PV	21.038.3	297
HB025C160	27.210.2	362	HS032C100	27.012.0	363	KP063	25.007.3	326	KSM160V	21.028.3	297
HB025C200	27.211.2	362	HS032C150	27.013.0	363	KP063P	25.017.3	326	KSM200	21.009.3	297
HB025C250	27.212.2	362	HS032C200	27.014.0	363	KP063PV	25.037.3	326	KSM200P	21.019.3	297
HB032C050	27.069.2	363	HS032C250	27.015.0	363	KP063V	25.027.3	326	KSM200PV	21.039.3	297
HB032C100	27.070.2	363	HS032C300	27.016.0	363	KP080	25.008.3	326	KSM200V	21.029.3	297
HB032C150	27.071.2	363	HS032C400	27.017.0	363	KP080P	25.018.3	326	LUB 2-00	16.003.3	400
HB032C200	27.072.2	363	HS032C500	27.018.0	363	KP080PV	25.038.3	326	LUB 3-00	16.007.3	402
HB032C250	27.073.2	363	HS040C050	27.019.0	363	KP080V	25.028.3	326	LUB 4-00	16.011.3	404
HB032C300	27.074.2	363	HS040C100	27.020.0	363	KP100	25.009.3	326	LUB 6-00	16.044.3	406
HB032C400	27.075.2	363	HS040C150	27.021.0	363	KP100P	25.019.3	326	LUB 6N-00	16.119.0	468
HB032C500	27.076.2	363	HS040C200	27.022.0	363	KP100PV	25.039.3	326	M21A1...		266
HB040C050	27.077.2	363	HS040C250	27.023.0	363	KP100V	25.029.3	326	M21A2...		266
HB040C100	27.078.2	363	HS040C300	27.024.0	363	KR032	25.104.3	326	M21A3...		266
HB040C150	27.079.2	363	HS040C400	27.025.0	363	KR032P	25.114.3	326	M21A4...		266
HB040C200	27.080.2	363	HS040C500	27.026.0	363	KR032PV	25.134.3	326	M21A5...		266
HB040C250	27.081.2	363	HS050C050	27.027.0	363	KR032V	25.124.3	326	M21A6...		266
HB040C300	27.082.2	363	HS050C100	27.028.0	363	KR040	25.105.3	326	M21B1...		266
HB040C400	27.083.2	363	HS050C150	27.029.0	363	KR040P	25.115.3	326	M21B2...		266
HB040C500	27.084.2	363	HS050C200	27.030.0	363	KR040PV	25.135.3	326	M21B3...		266
HB050C050	27.085.2	363	HS050C250	27.031.0	363	KR040V	25.125.3	326	M21B4...		266
HB050C100	27.086.2	363	HS050C300	27.032.0	363	KR050	25.106.3	326	M21B5...		266
HB050C150	27.087.2	363	HS050C400	27.033.0	363	KR050P	25.116.3	326	M21B6...		266
HB050C200	27.088.2	363	HS050C500	27.034.0	363	KR050PV	25.136.3	326	M21M1...		266
HB050C250	27.089.2	363	HS063C050	27.035.0	363	KR050V	25.126.3	326	M21M2...		266
HB050C300	27.090.2	363	HS063C100	27.036.0	363	KR063	25.107.3	326	M21M3...		266
HB050C400	27.091.2	363	HS063C150	27.037.0	363	KR063P	25.117.3	326	M21M4...		266
HB050C500	27.092.2	363	HS063C200	27.038.0	363	KR063PV	25.137.3	326	M21M5...		266
HB063C050	27.093.2	363	HS063C250	27.039.0	363	KR063V	25.127.3	326	M21M6...		266
HB063C100	27.094.2	363	HS063C300	27.040.0	363	KR080	25.108.3	326	M21S1...		266
HB063C150	27.095.2	363	HS063C400	27.041.0	363	KR080P	25.118.3	326	M21S2...		266
HB063C200	27.096.2	363	HS063C500	27.042.0	363	KR080PV	25.138.3	326	M21S3...		266
HB063C250	27.097.2	363	HS080C050	27.043.0	363	KR080V	25.128.3	326	M21S4...		266
HB063C300	27.098.2	363	HS080C100	27.044.0	363	KR100	25.109.3	326	M21S5...		266
HB063C400	27.099.2	363	HS080C150	27.045.0	363	KR100P	25.119.3	326	M21S6...		266
HB063C500	27.100.2	363	HS080C200	27.046.0	363	KR100PV	25.139.3	326	M22A1...		266
HB080C050	27.230.2	363	HS080C250	27.047.0	363	KR100V	25.129.3	326	M22A2...		266

INDEX

indice alfanumerico ordinato per sigla

product reference directory - ordered by part number



sigla part number	codice code	pagina page	sigla part number	codice code	pagina page	sigla part number	codice code	pagina page	sigla part number	codice code	pagina page
M22A3...		266	P12M3...		313	PED 502 S	01.072.4	67	RFU 1/2	12.003.4	201
M22A4...		266	P12M4...		313	PEDS 502 B	01.081.4	67	RFU 1/4	12.001.4	201
M22A5...		266	P13M1...		313	PEDS 502 M	01.080.4	67	RFU 1/8.1	12.010.4	201
M22A6...		266	P13M2...		313	PR 2-00	16.100.0	454	RFU 1/8.2	12.000.4	201
M22B1...		266	P13M3...		313	PR 3-00	16.012.0	454	RFU 1/8.3	12.000.4-1/4	201
M22B2...		266	P13M4...		313	PR 4-00	16.020.0	454	RFU 3/8	12.002.4	201
M22B3...		266	P21M1...		313	R11M1...		313	RFU M5	12.047.4	201
M22B4...		266	P21M2...		313	R11M2...		313	RFUM 1/4	12.005.4	202
M22B5...		266	P21M3...		313	R11M3...		313	RFUM 1/8	12.004.4	202
M22B6...		266	P21M4...		313	R11M4...		313	RM 010	RM 010	64
M22M1...		266	P22M1...		313	R12M1...		313	RM 050 N	RM 050 N	64
M22M2...		266	P22M2...		313	R12M2...		313	RM 050 R	RM 050 R	64
M22M3...		266	P22M3...		313	R12M3...		313	RM 055 N	RM 055 N	64
M22M4...		266	P22M4...		313	R12M4...		313	RM 055 R	RM 055 R	64
M22M5...		266	P23M1...		313	R13M1...		313	RM 056 R	RM 056 R	64
M22M6...		266	P23M2...		313	R13M2...		313	RM 065 R	RM 065 R	64
M22S1...		266	P23M3...		313	R13M3...		313	RM 066 R	RM 066 R	64
M22S2...		266	P23M4...		313	R13M4...		313	RM 200 N	RM 200 N	65
M22S3...		266	P31M1...		313	R21M1...		313	RM 300 N	RM 300 N	65
M22S4...		266	P31M2...		313	R21M2...		313	RM 313 N	RM 313 N	65
M22S5...		266	P31M3...		313	R21M3...		313	RM 350 N	RM 350 N	65
M22S6...		266	P31M4...		313	R21M4...		313	RM 383 N	RM 383 N	65
M40-00	17.001.0	462	P32M1...		313	R22M1...		313	RM 400 N	RM 400 N	65
M50-00	17.002.0	462	P32M2...		313	R22M2...		313	RM 413 N	RM 413 N	65
M63-00	17.003.0	462	P32M3...		313	R22M3...		313	RM 450 N	RM 450 N	65
MFIL 2-S	16.024.3	384	P32M4...		313	R22M4...		313	RM 483 N	RM 483 N	65
MFIL 3-S	16.025.3	384	P33M1...		313	R23M1...		313	RPE 3 A NC	16.052.3	444
MFIL 4-S	16.026.3	384	P33M2...		313	R23M2...		313	RPE 3 V NA	16.051.3	444
MLD1	00.071.2	187	P33M3...		313	R23M3...		313	RPE 3 V NC	16.050.3	444
MLD2	02.001.2	196	P33M4...		313	R23M4...		313	RPE 4 A NC	16.055.3	447
MREG 1-08	16.018.4	388	P41M1...		313	R31M1...		313	RPE 4 V NA	16.054.3	447
MREG 2-04	16.016.4	388	P41M2...		313	R31M2...		313	RPE 4 V NC	16.053.3	447
MREG 2-08	16.011.4	388	P41M3...		313	R31M3...		313	RS1-A	RS1/A	364
N11B2...		288	P41M4...		313	R31M4...		313	RS1-A 5MT	RS1/A 5MT	364
N11B4...		288	P42M1...		313	R32M1...		313	RS2-A	RS2/A	364
N11M2...		288	P42M2...		313	R32M2...		313	RS3-A	RS3/A	364
N11M4...		288	P42M3...		313	R32M3...		313	RS4-A	RS4/A	364
N12B2...		288	P42M4...		313	R32M4...		313	RS5-C	RS5/C	364
N12B4...		288	P43M1...		313	R33M1...		313	RS6-3F	RS6/3F	365
N12M2...		288	P43M2...		313	R33M2...		313	RS7-3F	RS7/3F	365
N12M4...		288	P43M3...		313	R33M3...		313	RSTC 1/4	11.018.4	219
N13B2...		288	P43M4...		313	R33M4...		313	RSTC 1/8	11.017.4	219
N13B4...		288	PAI 2-00	16.010.2	452	R41M1...		313	RSW 1/2	11.014.4	219
N13M2...		288	PAI 3-00	16.041.0	452	R41M2...		313	RSW 1/4	11.013.4	219
N13M4...		288	PAI 4-00	16.042.0	453	R41M3...		313	RSW 1/8	11.012.4	219
N21B2...		288	PAI 6-00	16.076.0	453	R41M4...		313	RSW 3/8	11.039.4	219
N21B4...		288	PBISO32	26.037.2N	305	R42M1...		313	SCR 3-E	16.035.3	434
N21M2...		288	PBISO40	26.038.2N	305	R42M2...		313	SCR 3-P	16.029.4	434
N21M4...		288	PBISO50	26.039.2N	305	R42M3...		313	SCR 4-E	16.019.3	436
N22B2...		288	PBISO63	26.040.2N	305	R42M4...		313	SCR 4-P	16.013.4	436
N22B4...		288	PBISO80	26.041.2N	305	R43M1...		313	SGM032	21.100.2	296
N22M2...		288	PBISO100	26.042.2N	305	R43M2...		313	SGM032P	21.110.2	296
N22M4...		288	PBISO125	26.043.2N	305	R43M3...		313	SGM032PV	21.130.2	296
N23B2...		288	PBISO160	26.044.2N	305	R43M4...		313	SGM032V	21.120.2	296
N23B4...		288	PBISO200	26.045.2N	305	REG 2-04	16.015.3	390	SGM040	21.101.2	296
N23M2...		288	PBUN032	26.537.2	332	REG 2-08	16.001.3	390	SGM040P	21.111.2	296
N23M4...		288	PBUN040	26.538.2	332	REG 2-08-SR	16.032.3	392	SGM040PV	21.131.2	296
P 22804 A	P 22804 A	64	PBUN050	26.539.2	332	REG 3-08	16.005.3	394	SGM040V	21.121.2	296
P 22804 B	P 22804 B	64	PBUN063	26.540.2	332	REG 4-08	16.009.3	396	SGM050	21.102.2	296
P 22804 G	P 22804 G	64	PBUN080	26.541.2	332	REG 6-10	16.043.3	398	SGM050P	21.112.2	296
P 22804 V	P 22804 V	64	PBUN100	26.542.2	332	REG 6N-10	16.118.0	466	SGM050PV	21.132.2	296
P11M1...		313	PDMC08-10	26.101.2N	273	RFB 1/2	12.009.4	203	SGM050V	21.122.2	296
P11M2...		313	PDMC12-16	26.102.2N	273	RFB 1/4	12.007.4	203	SGM063	21.103.2	296
P11M3...		313	PDMC20-25	26.103.2N	273	RFB 1/8	12.006.4	203	SGM063P	21.113.2	296
P11M4...		313	PED 304 M	08.184.4	68	RFB 3/8	12.008.4	203	SGM063PV	21.133.2	296
P12M1...		313	PED 502 B	01.053.4	67	RFB M5	12.049.4	203	SGM063V	21.123.2	296
P12M2...		313	PED 502 M	01.052.4	67	RFP 1/8.2	12.011.4	202	SGM080	21.104.2	296

indice alfanumerico ordinato per sigla

product reference directory - ordered by part number



sigla part number	codice code	pagina page	sigla part number	codice code	pagina page	sigla part number	codice code	pagina page	sigla part number	codice code	pagina page
SGM080P	21.114.2	296	T13M5...		279	UB050C050	27.143.2	361		00.050.2	120
SGM080PV	21.134.2	296	T21M2...		279	UB050C100	27.144.2	361		00.051.2	120
SGM080V	21.124.2	296	T21M3...		279	UB050C150	27.145.2	361		00.051.3	90
SGM100	21.105.2	296	T21M4...		279	UB050C200	27.146.2	361		00.052.2	125
SGM100P	21.115.2	296	T21M5...		279	UB050C250	27.147.2	361		00.052.3	92
SGM100PV	21.135.2	296	T22M2...		279	UB050C300	27.148.2	361		00.053.2	125
SGM100V	21.125.2	296	T22M3...		279	UB050C400	27.149.2	361		00.053.3	92
SGM125	21.106.2	296	T22M4...		279	UB050C500	27.150.2	361		00.054.2	125
SGM125P	21.116.2	296	T22M5...		279	UB063C050	27.151.2	361		00.054.3	92
SGM125PV	21.136.2	296	T23M2...		279	UB063C100	27.152.2	361		00.055.2	125
SGM125V	21.126.2	296	T23M3...		279	UB063C150	27.153.2	361		00.055.3	92
SGM160	21.107.2	296	T23M4...		279	UB063C200	27.154.2	361		00.056.2	125
SGM160P	21.117.2	296	T23M5...		279	UB063C250	27.155.2	361		00.056.3	92
SGM160PV	21.137.2	296	TA1	00.073.2	188	UB063C300	27.156.2	361		00.057.2	125
SGM160V	21.127.2	296	TA2	02.002.2	197	UB063C400	27.180.2	361		00.058.2	125
SGM200	21.108.2	296	TB1	00.082.2	189	UB063C500	27.181.2	361		00.059.2	125
SGM200P	21.118.2	296	TB2	02.003.2	197	UB080C050	27.182.2	361		00.060.2	125
SGM200PV	21.138.2	296	TC1	00.077.2	189	UB080C100	27.183.2	361		00.064.2	126
SGM200V	21.128.2	296	TD751	05.023.2	169	UB080C150	27.184.2	361		00.064.3	91
SGT032	26.192.2N	284	TD851	05.031.2	150	UB080C200	27.185.2	361		00.067.2	128
SGT032A	26.430.2	284	TL1	00.083.2	188	UB080C250	27.186.2	361		00.071.3	90
SGT032AV	26.433.2	284	TL2	02.004.2	196	UB080C300	27.187.2	361		00.072.3	92
SGT032V	26.360.2N	284	TP1	00.068.2	188	UB080C400	27.188.2	361		00.073.3	92
SGT040	26.193.2N	284	TPC1	00.084.2	189	UB080C500	27.189.2	361		00.074.3	92
SGT040A	26.431.2	284	TRP 8	03.016.4	218	UB100C050	27.190.2	361		00.074.4	248
SGT040AV	26.434.2	284	TS12T16	26.011.0	356	UB100C100	27.191.2	361		00.075.3	92
SGT040V	26.361.2N	284	TS160T200	26.018.0	356	UB100C150	27.192.2	361		00.076.3	92
SGT050	26.194.2N	284	TS25T32	26.013.0	356	UB100C200	27.193.2	361		00.077.3	92
SGT050A	26.432.2	284	TS50T63	26.015.0	356	UB100C250	27.194.2	361		00.078.2	123
SGT050AV	26.435.2	284	TS751	05.024.2	169	UB100C300	27.195.2	361		00.078.3	92
SGT050V	26.362.2N	284	TS80T100	26.016.0	356	UB100C400	27.196.2	361		00.079.3	92
SH1-P	SH1/P	365	TS851	05.032.2	150	UB100C500	27.197.2	361		00.080.2	126
SH2-P	SH2/P	365	TS8T10	26.010.0	356	VNR 1/4 FF	11.001.4	206		00.080.3	92
SL1	00.267.1	187	TST125	26.017.0	356	VNR 1/4 MF	11.047.4	206		00.085.2	191
SN12D16	26.019.0	357	TST20	26.012.0	356	VNR 1/8 FF	11.000.4	205		00.086.2	191
SN25D32	26.021.0	357	TST40	26.014.0	356	VNR 1/8 MF	11.006.4	205		00.087.2	191
SN50D63	26.023.0	357	UB012C050	27.117.2	360	VNR 1/8 MFR	11.008.4	206		00.088.0	98
SN80D100	26.024.0	357	UB012C100	27.118.2	360	VNR M5 FF	11.010.4	205		00.088.3	90
SND20	26.020.0	357	UB012C160	27.119.2	360		00.004.3	91		00.093.2	101
SND40	26.022.0	357	UB012C200	27.120.2	360		00.008.3	241		00.094.3	94
SNINT032B	26.094.2N	307	UB012C250	27.121.2	360		00.011.3	123		00.095.2	127
SNINT040-050B	26.095.2N	307	UB020C050	27.122.2	360		00.021.3	123		00.095.3	94
SNINT063-080B	26.097.2N	307	UB020C100	27.123.2	360		00.023.3	123		00.096.3	95
SNINT100-125B	26.099.2N	307	UB020C160	27.124.2	360		00.024.3	123		00.097.3	95
SR-M3	16.013.3	440	UB020C200	27.125.2	360		00.028.0	98		00.098.3	96
SR-M4	16.014.3	441	UB020C250	27.126.2	360		00.029.0	98		00.099.3	96
SR-M6	16.046.3	442	UB025C050	27.198.2	360		00.029.2	128		00.100.3	97
STF 2	16.021.0	458	UB025C100	27.199.2	360		00.030.0	98		00.101.3	97
STF 3	16.011.0	458	UB025C160	27.200.2	360		00.031.0	98		00.108.2	120
STF 3A	16.083.0	458	UB025C200	27.201.2	360		00.036.2	120		00.109.2	173
STF 3B	16.030.0	459	UB025C250	27.202.2	360		00.037.2	120		00.130.3	95
STF 4	16.019.0	459	UB032C050	27.127.2	361		00.038.2	120		00.131.3	95
STF 6	16.077.0	459	UB032C100	27.128.2	361		00.039.2	120		00.134.3	97
STF 6N	16.123.0	476	UB032C150	27.129.2	361		00.040.2	120		00.135.3	97
STF 6NA	16.124.0	476	UB032C200	27.130.2	361		00.041.2	120		00.136.3	50
STF 6NB	16.125.0	476	UB032C250	27.131.2	361		00.042.3	128		00.137.3	50
T11M2...		279	UB032C300	27.132.2	361		00.043.3	128		00.138.3	50
T11M3...		279	UB032C400	27.133.2	361		00.044.3	128		00.139.3	50
T11M4...		279	UB032C500	27.134.2	361		00.044.4	124		00.160.4	51
T11M5...		279	UB040C050	27.135.2	361		00.045.3	128		00.163.4	51
T12M2...		279	UB040C100	27.136.2	361		00.045.4	124		00.164.4	51
T12M3...		279	UB040C150	27.137.2	361		00.046.3	128		00.167.0	98
T12M4...		279	UB040C200	27.138.2	361		00.047.2	183		00.177.4	250
T12M5...		279	UB040C250	27.139.2	361		00.047.4	241		00.197.0	98
T13M2...		279	UB040C300	27.140.2	361		00.048.2	183		00.232.1	190
T13M3...		279	UB040C400	27.141.2	361		00.049.2	183		00.233.1	190
T13M4...		279	UB040C500	27.142.2	361		00.049.4	124		00.234.1	190

indice alfanumerico ordinato per sigla

product reference directory - ordered by part number



sigla part number	codice code	pagina page	sigla part number	codice code	pagina page	sigla part number	codice code	pagina page	sigla part number	codice code	pagina page
	00.235.1	190		01.033.4	123		05.053.2	167		11.035.4	205
	00.236.1	190		01.034.3	128		05.054.1	153		11.036.4	206
	00.237.1	190		01.035.2	120		05.054.2	167		11.037.4	206
	00.251.0	99		01.035.3	128		05.055.1	153		11.040.4	206
	00.252.0	102		01.036.2	120		05.055.2	167		11.042.4	205
	00.253.0	102		01.036.3	128		05.056.1	153		11.044.4	254
	00.254.0	102		01.038.2	128		05.056.2	167		11.045.4	205
	00.255.0	102		01.042.2	125		05.057.1	153		11.046.4	205
	00.256.0	102		01.043.2	125		05.057.2	167		11.048.4	206
	00.257.0	102		01.044.2	125		05.058.1	153		11.049.4	206
	00.258.0	99		01.044.4	232		05.058.2	167		11.050.4	205
	00.259.0	99		01.045.2	125		05.059.1	153		11.055.4	205
	00.260.0	99		01.045.4	123		05.059.2	167		11.056.4	206
	00.261.0	99		01.046.2	125		05.060.1	153		11.059.4	206
	00.284.0	100		01.046.4	233		05.113.1	153		11.066.4	254
	00.305.0	100		01.047.2	125		05.114.1	153		11.076.4	255
	00.306.0	98		01.047.4	124		06.001.2	187		11.077.4	255
	00.332.0	100		01.048.2	125		08.015.2	31		16.004.2	460
	00.333.0	100		01.048.4	124		08.017.2	31		16.005.2	461
	00.336.0	100		01.049.2	126		08.021.4	208		16.006.2	461
	00.340.0	102		01.050.2	126		08.022.4	208		16.008.2	457
	00.341.0	102		01.055.2	178		08.023.4	208		16.009.2	457
	00.342.0	102		01.061.2	120		08.025.4	208		16.031.0	457
	00.343.0	102		01.065.2	174		08.026.4	208		16.032.0	457
	00.344.0	98		01.066.2	174		08.027.4	208		16.033.0	457
	00.345.0	98		01.066.3	90		08.039.4	209		16.061.0	457
	00.346.0	98		01.068.3	90		08.049.4	209		16.062.0	457
	00.347.0	98		01.078.2	123		08.092.1	209		16.063.0	457
	00.348.0	99		01.087.0	69		08.121.4	211		16.064.0	457
	00.349.0	99		01.088.0	69		08.127.4	210		16.065.0	457
	00.350.0	99		02.030.2	129		08.133.4	210		16.066.0	457
	00.351.0	99		02.031.2	129		08.156.4	252		16.067.0	457
	00.370.0	100		02.032.2	129		08.180.4	212		16.068.0	457
	00.392.0	100		02.033.2	129		08.181.4	212		16.069.0	457
	00.393.0	100		03.025.4	218		08.197.4	68		16.078.0	457
	00.394.0	98		04.002.4	209		08.198.4	68		16.084.0	457
	00.395.0	98		04.003.4	209		08.207.4	68		16.098.0	457
	00.396.0	99		05.001.2	172		10.001.4	243		16.099.0	457
	00.397.0	99		05.002.2	172		10.003.3	226		16.104.0	457
	00.398.0	102		05.003.2	172		10.003.4	245		16.105.0	457
	00.399.0	102		05.004.2	172		10.009.4	244		16.106.0	457
	000.510.7	300		05.005.2	172		10.013.4	256		16.107.0	457
	000.511.7	300		05.006.2	172		10.014.4	256		16.108.0	457
	000.512.7	300		05.007.2	172		10.015.4	257		17.004.0	214
	000.513.7	300		05.008.2	172		10.016.4	257		17.005.0	214
	000.514.7	300		05.009.2	172		10.017.3	238		17.006.0	216
	000.515.7	300		05.010.2	172		10.018.3	230		17.007.0	214
	000.516.7	300		05.012.2	172		10.019.3	239		17.008.0	214
	000.523.7	327		05.013.2	172		10.021.4	246		17.009.0	217
	000.524.7	327		05.014.2	172		10.027.4	237		17.010.0	217
	000.525.7	327		05.015.2	172		10.029.4	236		17.011.0	215
	000.526.7	327		05.016.2	172		10.035.4	229		17.012.0	215
	000.527.7	327		05.017.2	172		11.002.4	205		20.100.4	277
	000.528.7	327		05.018.2	172		11.003.4	206		20.101.4	277
	01.005.3	90		05.019.2	172		11.004.4	205		20.102.4	277
	01.007.3	123		05.020.2	172		11.005.4	206		20.103.4	277
	01.008.3	234		05.035.2	171		11.007.4	205		20.104.4	277
	01.014.2	120		05.036.2	172		11.009.4	205		20.105.4	277
	01.015.2	120		05.037.2	172		11.011.4	205		20.106.4	277
	01.019.2	120		05.039.2	172		11.024.4	205		20.107.4	277
	01.020.2	120		05.048.2	148		11.027.4	205		20.108.4	277
	01.021.2	120		05.049.2	148		11.028.4	206		20.109.4	277
	01.022.2	120		05.050.2	148		11.030.4	206		20.110.4	277
	01.029.2	128		05.051.2	148		11.031.4	205		20.111.4	277
	01.032.3	128		05.052.1	153		11.032.4	206		20.112.4	277
	01.032.4	123		05.052.2	148		11.033.4	206		20.113.4	277
	01.033.3	128		05.053.1	153		11.034.4	205		20.114.4	277

indice alfanumerico ordinato per sigla

product reference directory - ordered by part number



sigla part number	codice code	pagina page	sigla part number	codice code	pagina page	sigla part number	codice code	pagina page	sigla part number	codice code	pagina page
	20.115.4	277									
	20.116.4	277									
	20.117.4	277									
	26.039.0	368									
	26.040.0	368									
	26.041.0	368									
	26.042.0	368									
	26.145.0	369									
	26.147.0	368									
	26.164.0	366									
	26.165.0	366									
	26.166.0	366									
	26.167.0	366									
	26.194.0	369									
	26.195.0	369									
	26.196.0	369									
	26.219.2	368									
	26.229.0	368									
	26.230.0	368									
	26.231.0	368									
	26.232.0	368									
	36.625.0	213									
	AT.005.4	261									
	AU.000.1	221									
	AU.001.1	221									
	AU.002.1	220									
	AU.003.1	220									
	AU.004.1	220									
	AU.005.1	220									
	AU.006.1	220									
	AU.008.1	221									
	AU.009.1	221									
	AU.011.1	220									
	AU.013.1	220									
	AU.014.1	220									
	AU.015.1	220									
	AU.016.1	220									
	AU.017.1	221									
	AU.018.1	221									
	AU.019.1	221									
	AU.020.1	221									
	AU.021.1	221									
	AU.022.1	221									
	AU.023.1	221									
	AU.024.1	221									
	AU.025.1	221									
	AU.027.1	221									
	AU.061.1	101									
	AU.062.1	101									
	AU.063.1	101									
	AU.064.1	101									
	AU.065.1	101									
	AU.066.1	101									
	AU.067.1	101									
	AU.068.1	101									
	AU.069.1	101									
	AU.070.1	101									
	AX.007.4	247									

INDEX

indice alfanumerico ordinato per codice

product reference directory - ordered by code



sigla part number	codice code	pagina page	sigla part number	codice code	pagina page	sigla part number	codice code	pagina page	sigla part number	codice code	pagina page
	00.004.3	91		00.048.2	183	TC1	00.077.2	189	521 BB90	00.138.4	63
321 CTT	00.004.4	48		00.049.2	183		00.077.3	92		00.139.3	50
321 ME90 S	00.005.3	110	521 EED	00.049.3	107	321 MP	00.077.4	35	321 CL90	00.139.4	45
521 CTT	00.005.4	49		00.049.4	124		00.078.2	123	521 CL90	00.140.4	45
321 EE90 S	00.006.3	112		00.050.2	120		00.078.3	92	321 BB90	00.141.4	63
521 ME90 S	00.007.3	111	321 EED	00.050.3	106	521 MP	00.078.4	35	5213A ML	00.151.4	50
	00.008.3	241	321 LL	00.050.4	52		00.079.3	92		00.160.4	51
521 EE90 S	00.009.3	113		00.051.2	120	321 MPS	00.079.4	37		00.163.4	51
321 MEA	00.010.3	104		00.051.3	90		00.080.2	126		00.164.4	51
321 MCQ	00.010.4	88	521 LL	00.051.4	52		00.080.3	92		00.167.0	98
	00.011.3	123		00.052.2	125	321 MPSA	00.080.4	37	152 CFP	00.173.4	180
521 MCQ	00.011.4	88		00.052.3	92	521 MPS	00.081.4	37		00.177.4	250
521 ME	00.013.3	105	321 ML90	00.052.4	43	TB1	00.082.2	189		00.197.0	98
521 EE	00.014.3	107		00.053.2	125	321 MR	00.082.4	38		00.232.1	190
321 ME	00.015.3	104		00.053.3	92	TL1	00.083.2	188		00.233.1	190
321 MCS	00.015.4	88	321 LL90	00.053.4	44	521 MR	00.083.4	39		00.234.1	190
321 EE	00.016.3	106		00.054.2	125	TPC1	00.084.2	189		00.235.1	190
521 MCS	00.016.4	89		00.054.3	92	321 MRU	00.084.4	39		00.236.1	190
521 2PS	00.019.4	38	521 ML90	00.054.4	43		00.085.2	191		00.237.1	190
	00.021.3	123		00.055.2	125	521 MRU	00.085.4	39		00.251.0	99
321 CFP	00.021.4	77		00.055.3	92		00.086.2	191		00.252.0	102
321 MC	00.022.4	76	521 LL90	00.055.4	44	321 MRS	00.086.4	40		00.253.0	102
	00.023.3	123		00.056.2	125		00.087.2	191		00.254.0	102
321 MCA	00.023.4	76		00.056.3	92	321 MRSA	00.087.4	40		00.255.0	102
	00.024.3	123	5213C ML90	00.056.4	46		00.088.0	98		00.256.0	102
321 CCD	00.024.4	77		00.057.2	125		00.088.3	90		00.257.0	102
321 CC	00.025.4	77	5213C LL90	00.057.4	46	521 MRS	00.088.4	40		00.258.0	99
521 MC	00.027.4	76		00.058.2	125	321 MN	00.089.4	41		00.259.0	99
	00.028.0	98	5213A ML90	00.058.4	46	321 MNA	00.090.4	41		00.260.0	99
521 CC	00.028.4	78		00.059.2	125	521 MN	00.091.4	41		00.261.0	99
	00.029.0	98	321 ME90 L	00.059.3	110		00.093.2	101	SL1	00.267.1	187
	00.029.2	128	5213A LL90	00.059.4	46		00.094.3	94		00.284.0	100
521 CFP	00.029.4	78		00.060.2	125	152 CCD	00.094.4	180		00.305.0	100
	00.030.0	98	321 EE90 L	00.060.3	112		00.095.2	127		00.306.0	98
521 CCD	00.030.4	78	5213P LL90	00.060.4	46		00.095.3	94	DF1	00.307.0	189
	00.031.0	98	521 ME90 L	00.061.3	111	152 MC	00.095.4	180		00.332.0	100
5213C CC	00.031.4	79	321 MBA	00.061.4	61		00.096.3	95		00.333.0	100
321 CE	00.032.3	104	521 EE90 L	00.062.3	113	152 CC	00.096.4	180		00.336.0	100
5213A CC	00.032.4	79	521 EFP	00.063.3	108		00.097.3	95		00.340.0	102
321 ME AS	00.033.3	105		00.064.2	126		00.098.3	96		00.341.0	102
521 ME AS	00.034.3	106		00.064.3	91		00.099.3	96		00.342.0	102
521 CE	00.035.3	105	152 ME AS	00.064.4	181		00.100.3	97		00.343.0	102
	00.036.2	120	321 EFP	00.065.3	107		00.101.3	97		00.344.0	98
5213C EE	00.036.3	109	152 EE AS	00.065.4	182	153C CC	00.101.4	180		00.345.0	98
521 2P	00.036.4	36	321 EE AS	00.066.3	108	153A CC	00.102.4	180		00.346.0	98
	00.037.2	120	153C EE AS	00.066.4	182	153P CC	00.103.4	180		00.347.0	98
5213A EE	00.037.3	109		00.067.2	128		00.108.2	120		00.348.0	99
	00.038.2	120	521 EE AS	00.067.3	108		00.109.2	173		00.349.0	99
5213P EE	00.038.3	109	153A EE AS	00.067.4	182	321 CT	00.110.4	48		00.350.0	99
	00.039.2	120	TP1	00.068.2	188	521 CT	00.111.4	49		00.351.0	99
5213C EE AS	00.039.3	109	321 TT	00.068.4	47	152 ME	00.112.4	181		00.370.0	100
	00.040.2	120	521 TT	00.069.4	48	153P EE AS	00.113.4	182		00.392.0	100
5213A EE AS	00.040.3	109	321 MB90	00.070.4	62	152 EE	00.114.4	182		00.393.0	100
	00.041.2	120	MLD1	00.071.2	187	153C EE	00.116.4	182		00.394.0	98
5213P EE AS	00.041.3	109		00.071.3	90	153A EE	00.117.4	182		00.395.0	98
321 MBA90	00.041.4	62	521 MB90	00.071.4	62	153P EE	00.118.4	182		00.396.0	99
	00.042.3	128		00.072.3	92		00.130.3	95		00.397.0	99
5213P ML90	00.042.4	46	321 MB	00.072.4	61		00.131.3	95		00.398.0	102
	00.043.3	128	TA1	00.073.2	188	321 2P	00.133.4	35		00.399.0	102
5213P CC	00.043.4	79		00.073.3	92		00.134.3	97		000.510.7	300
	00.044.3	128	521 MB	00.073.4	61	321 2PS	00.134.4	38		000.511.7	300
	00.044.4	124		00.074.3	92		00.135.3	97		000.512.7	300
	00.045.3	128		00.074.4	248	321 CP	00.135.4	36		000.513.7	300
	00.045.4	124		00.075.3	92		00.136.3	50		000.514.7	300
	00.046.3	128	321 MT	00.075.4	47	521 CP	00.136.4	36		000.515.7	300
	00.047.2	183		00.076.3	92		00.137.3	50		000.516.7	300
	00.047.4	241	521 MT	00.076.4	47		00.138.3	50		000.523.7	327

indice alfanumerico ordinato per codice

product reference directory - ordered by code



sigla part number	codice code	pagina page	sigla part number	codice code	pagina page	sigla part number	codice code	pagina page	sigla part number	codice code	pagina page
	000.524.7	327		01.038.2	128	324 MEA	02.002.3	134		05.004.2	172
	000.525.7	327	582 EE	01.038.3	176	324 MCA	02.002.4	130	731 CFP	05.004.4	158
	000.526.7	327	322 EED	01.039.3	116	TB2	02.003.2	197		05.005.2	172
	000.527.7	327	522 EED	01.040.3	117	324 ME AS	02.003.3	134	751 MC	05.005.4	155
	000.528.7	327	382 ME	01.041.3	176	324 CFP	02.003.4	130		05.006.2	172
522 ORM	01.001.4	86	322 CT	01.041.4	58	TL2	02.004.2	196	751 CC	05.006.4	156
522 ANDM	01.002.4	86		01.042.2	125	324 EFP	02.004.3	134		05.007.2	172
382 EE	01.003.3	176	522 CT	01.042.4	59	324 CC	02.004.4	130	751 CCD	05.007.4	157
522 MCS	01.004.4	89		01.043.2	125	324 EE	02.005.3	135		05.008.2	172
	01.005.3	90		01.044.2	125	324 CCD	02.005.4	130	751 CFP	05.008.4	158
522 2OR	01.005.4	87		01.044.4	232	324 EE AS	02.006.3	135		05.009.2	172
522 2AND	01.006.4	87		01.045.2	125	524 MC	02.006.4	131		05.010.2	172
	01.007.3	123	522 EFP	01.045.3	118	324 EED	02.007.3	135	731 ME 00	05.010.4	161
	01.008.3	234		01.045.4	123	524 CFP	02.007.4	131	731 ME 01	05.011.4	161
582 MC	01.008.4	175		01.046.2	125	524 ME	02.008.3	136		05.012.2	172
522 ME	01.009.3	115		01.046.4	233	524 CC	02.008.4	131	731 ME 02	05.012.4	161
322 ORM	01.009.4	84		01.047.2	125	524 ME AS	02.009.3	136		05.013.2	172
522 EE	01.010.3	117		01.047.4	124	524 CCD	02.009.4	131	731 ME 03	05.013.4	161
322 ANDM	01.010.4	84		01.048.2	125	524 EFP	02.010.3	136		05.014.2	172
322 ME	01.011.3	114		01.048.4	124	5243C CC	02.010.4	131	731 ME 04	05.014.4	161
322 2OR	01.011.4	85		01.049.2	126	524 EE	02.011.3	137		05.015.2	172
322 EE	01.012.3	116	322 EFP	01.049.3	117	5243A CC	02.011.4	131	731 MEA 00	05.015.4	161
322 2AND	01.012.4	85	322 LL	01.049.4	60	524 EE AS	02.012.3	137		05.016.2	172
382 MC	01.013.4	175		01.050.2	126	5243P CC	02.012.4	131	731 MEA 01	05.016.4	161
	01.014.2	120	322 EE AS	01.050.3	118	524 EED	02.013.3	137		05.017.2	172
382 CC	01.014.4	175	522 LL	01.050.4	60	5243C EE	02.014.3	137	731 MEA 02	05.017.4	161
	01.015.2	120	522 EE AS	01.052.3	118	5243A EE	02.015.3	137		05.018.2	172
582 CC	01.015.4	175	PED 502 M	01.052.4	67	5243P EE	02.016.3	137	731 MEA 03	05.018.4	161
322 MEA	01.017.3	114	PED 502 B	01.053.4	67	5243C EE AS	02.017.3	137		05.019.2	172
322 ME AS	01.018.3	115	322 ML90	01.054.4	53	5243A EE AS	02.018.3	137	731 MEA 04	05.019.4	161
	01.019.2	120		01.055.2	178	5243P EE AS	02.019.3	137		05.020.2	172
522 ME AS	01.019.3	116	322 LL90	01.055.4	54		02.030.2	129	731 ME AS 00	05.020.4	162
	01.020.2	120	522 ML90	01.056.4	53		02.031.2	129	CS751	05.021.2	170
522 CE	01.020.3	115	522 LL90	01.057.4	54		02.032.2	129	731 ME AS 01	05.021.4	162
	01.021.2	120	5223P LL90	01.058.4	56		02.033.2	129	CS731	05.022.2	170
5223C EE	01.021.3	119	5223C LL90	01.059.4	56	252 MC	02.050.4	193	731 ME AS 02	05.022.4	162
322 CFP	01.021.4	82	5223A LL90	01.060.4	56	252 CC	02.051.4	193	TD751	05.023.2	169
	01.022.2	120		01.061.2	120	252 CCD	02.052.4	193	731 ME AS 03	05.023.4	162
5223A EE	01.022.3	119	5223C ML90	01.061.4	56	252 CFP	02.053.4	193	TS751	05.024.2	169
322 MC	01.022.4	80	5223A ML90	01.062.4	56	253C CC	02.054.4	193	731 ME AS 04	05.024.4	162
5223P EE	01.023.3	119	5223P ML90	01.063.4	56	253A CC	02.055.4	193	BM751	05.025.2	168
322 MCA	01.023.4	80		01.065.2	174	253P CC	02.056.4	193	731 EE 00	05.025.4	164
5223C EE AS	01.024.3	119	522 CL90	01.065.4	55	252 ME	02.070.3	194	DC751	05.026.2	168
322 CCD	01.024.4	82		01.066.2	174	252 EE	02.071.3	195	731 EE 01	05.026.4	164
5223A EE AS	01.025.3	119		01.066.3	90	252 EFP	02.072.3	194	DR751	05.027.2	168
322 CC	01.025.4	81	322 MT	01.066.4	57	252 ME AS	02.073.3	194	731 EE 02	05.027.4	164
5223P EE AS	01.026.3	119	322 TT	01.067.4	57	252 EE AS	02.074.3	195	DD751	05.028.2	170
522 MC	01.027.4	81		01.068.3	90	253C EE	02.075.3	195	731 EE 03	05.028.4	164
522 CC	01.028.4	83	522 MT	01.068.4	57	253A EE	02.076.3	195	BS851	05.029.1	149
	01.029.2	128	522 TT	01.069.4	58	253P EE	02.077.3	195	CS851	05.029.2	152
322 CE	01.029.3	114	522 CC SUP	01.070.4	84	253C EE AS	02.078.3	195	731 EE 04	05.029.4	164
522 CFP	01.029.4	83	PED 502 S	01.072.4	67	253A EE AS	02.079.4	195	BM851	05.030.2	149
522 CCD	01.030.4	83	5223P CC	01.073.4	79	253P EE AS	02.080.4	195	731 EE AS 00	05.030.4	165
	01.032.3	128	522 MC SUP	01.074.4	81	DP 2018 F	03.003.4	259	TD851	05.031.2	150
	01.032.4	123		01.078.2	123	DP 2005	03.009.4	260	731 EE AS 01	05.031.4	165
	01.033.3	128	322 CTT	01.078.4	58	305 LL	03.011.4	31	TS851	05.032.2	150
	01.033.4	123	522 CTT	01.079.4	59	TRP 8	03.016.4	218	731 EE AS 02	05.032.4	165
	01.034.3	128	PEDS 502 M	01.080.4	67	DP 2010 E	03.020.4	258	DC851	05.033.2	151
5223C CC	01.034.4	79	PEDS 502 B	01.081.4	67		03.025.4	218	731 EE AS 03	05.033.4	165
	01.035.2	120	322 CL90	01.082.4	55		04.002.4	209	DR851	05.034.2	151
	01.035.3	128	322 MCS	01.083.4	89		04.003.4	209	731 EE AS 04	05.034.4	165
5223A CC	01.035.4	79		01.087.0	69		05.001.2	172		05.035.2	171
	01.036.2	120		01.088.0	69	731 MC	05.001.4	155	731 EFP 00	05.035.4	163
	01.036.3	128	MLD2	02.001.2	196		05.002.2	172		05.036.2	172
322 CC SUP	01.036.4	82	324 ME	02.001.3	134	731 CC	05.002.4	156	731 EFP 01	05.036.4	163
582 ME	01.037.3	176	324 MC	02.001.4	130		05.003.2	172		05.037.2	172
322 MC SUP	01.037.4	80	TA2	02.002.2	197	731 CCD	05.003.4	157	731 EFP 02	05.037.4	163

indice alfanumerico ordinato per codice

product reference directory - ordered by code



sigla part number	codice code	pagina page	sigla part number	codice code	pagina page	sigla part number	codice code	pagina page	sigla part number	codice code	pagina page
731 EFP 03	05.038.4	163	851 EE 04	05.084.4	146	451 MG	05.148.4	74	204 MV	08.125.4	19
	05.039.2	172	7513C EE AS 00	05.085.4	166	451 MGN	05.149.4	74		08.127.4	210
731 EFP 04	05.039.4	163	7513C EE AS 01	05.086.4	166	8513C CC	05.150.4	142	204 MB UL	08.130.4	20
751 ME 00	05.040.4	161	7513C EE AS 02	05.087.4	166	8513A CC	05.151.4	142		08.133.4	210
751 ME 01	05.041.4	161	7513C EE AS 03	05.088.4	166	7513C CC	05.152.4	159	205 MA	08.141.4	22
751 ME 02	05.042.4	161	7513C EE AS 04	05.089.4	166	7513A CC	05.153.4	159	2.305 MB	08.146.4	29
751 ME 03	05.043.4	161	7513A EE AS 00	05.090.4	166		06.001.2	187	204 MV UL	08.149.4	21
751 ME 04	05.044.4	161	7513A EE AS 01	05.091.4	166	152 EFP	06.001.4	181	315 MA UL	08.151.4	24
751 ME AS 00	05.045.4	162	7513A EE AS 02	05.092.4	166		08.015.2	31	315 MS UL	08.152.4	26
751 ME AS 01	05.046.4	162	7513A EE AS 03	05.093.4	166		08.017.2	31	315 MV	08.153.4	24
751 ME AS 02	05.047.4	162	7513A EE AS 04	05.094.4	166		08.021.4	208		08.156.4	252
	05.048.2	148	751 EFP 00	05.095.4	163		08.022.4	208	205 MB	08.157.4	22
751 ME AS 03	05.048.4	162	751 EFP 01	05.096.4	163		08.023.4	208	314 MV UL	08.158.4	21
	05.049.2	148	751 EFP 02	05.097.4	163		08.025.4	208	204 MS UL	08.160.4	21
751 ME AS 04	05.049.4	162	751 EFP 03	05.098.4	163		08.026.4	208	205 MA UL	08.169.4	24
	05.050.2	148	751 EFP 04	05.099.4	163		08.027.4	208	204 MA UL	08.172.4	19
751 EE 00	05.050.4	164	851 ME AS 00	05.100.4	144	304 MA	08.030.4	17	205 MR	08.173.4	23
	05.051.2	148	851 ME AS 01	05.101.4	144	304 MB	08.031.4	17	315 MB UL	08.175.4	25
751 EE 01	05.051.4	164	DF851	05.102.2	152	304 MR	08.032.4	18		08.180.4	212
	05.052.1	153	851 ME AS 02	05.102.4	144	304 MS	08.033.4	18		08.181.4	212
	05.052.2	148	851 ME AS 03	05.103.4	144	304 MV	08.034.4	19	PED 304 M	08.184.4	68
751 EE 02	05.052.4	164	851 ME AS 04	05.104.4	144	314 MA	08.035.4	17	205 MS	08.185.4	23
	05.053.1	153	851 EE AS 00	05.105.4	146	314 MB	08.036.4	17	205 MV	08.186.4	24
	05.053.2	167	851 EE AS 01	05.106.4	146	314 MR	08.037.4	18	205 MB UL	08.187.4	25
751 EE 03	05.053.4	164	851 EE AS 02	05.107.4	146	314 MS	08.038.4	18	315 MR UL	08.188.4	25
	05.054.1	153	851 EE AS 03	05.108.4	146		08.039.4	209	205 MS UL	08.189.4	26
	05.054.2	167	851 EE AS 04	05.109.4	146	305 MA	08.040.4	22	315 MV UL	08.190.4	26
751 EE 04	05.054.4	164	8513C EE 00	05.110.4	147	305 MB	08.041.4	22	205 MV UL	08.191.4	26
	05.055.1	153	8513C EE 01	05.111.4	147	305 MR	08.042.4	23	2.315 MB	08.192.4	29
	05.055.2	167	8513C EE 02	05.112.4	147	305 MS	08.043.4	23	505 MB UL	08.193.4	30
751 EE AS 00	05.055.4	165		05.113.1	153	305 MV	08.044.4	24	2.305 MB UL	08.194.4	30
	05.056.1	153	8513C EE 03	05.113.4	147	315 MA	08.045.4	22	2.315 MB UL	08.195.4	30
	05.056.2	167		05.114.1	153	315 MB	08.046.4	22	204 MR UL	08.196.4	20
751 EE AS 01	05.056.4	165	8513C EE 04	05.114.4	147	315 MR	08.047.4	23		08.197.4	68
	05.057.1	153	8513A EE 00	05.115.4	147	315 MS	08.048.4	23		08.198.4	68
	05.057.2	167	8513A EE 01	05.116.4	147		08.049.4	209		08.207.4	68
751 EE AS 02	05.057.4	165	8513A EE 02	05.117.4	147	304 MA UL	08.050.4	19	304 MGR	08.212.4	27
	05.058.1	153	8513A EE 03	05.118.4	147	304 MB UL	08.051.4	20	304 MGG	08.213.4	27
	05.058.2	167	8513A EE 04	05.119.4	147	304 MR UL	08.052.4	20	304 MG	08.214.4	27
751 EE AS 03	05.058.4	165	851 EFP 00	05.120.4	145	304 MS UL	08.053.4	21	304 MGN	08.215.4	27
	05.059.1	153	851 EFP 01	05.121.4	145	304 MV UL	08.054.4	21	304 MGR UL	08.216.4	27
	05.059.2	167	851 EFP 02	05.122.4	145	305 MA UL	08.055.4	24	304 MGG UL	08.217.4	27
751 EE AS 04	05.059.4	165	851 EFP 03	05.123.4	145	305 MB UL	08.056.4	25	304 MG	08.218.4	27
	05.060.1	153	851 EFP 04	05.124.4	145	305 MR UL	08.057.4	25	304 MGN UL	08.219.4	27
7513C EE 00	05.060.4	166	8513C EE AS 00	05.125.4	147	305 MS UL	08.058.4	26	305 MGR	08.220.4	28
7513C EE 01	05.061.4	166	8513C EE AS 01	05.126.4	147	305 MV UL	08.059.4	26	305 MGG	08.221.4	28
7513C EE 02	05.062.4	166	8513C EE AS 02	05.127.4	147	314 MA UL	08.060.4	19	305 MG	08.222.4	28
7513C EE 03	05.063.4	166	8513C EE AS 03	05.128.4	147	314 MB UL	08.061.4	20	305 MGN	08.223.4	28
7513C EE 04	05.064.4	166	8513C EE AS 04	05.129.4	147	314 MR UL	08.062.4	20	305 MGR UL	08.224.4	28
7513A EE 00	05.065.4	166	8513A EE AS 00	05.130.4	147	314 MS UL	08.063.4	21	305 MGG UL	08.225.4	28
7513A EE 01	05.066.4	166	8513A EE AS 01	05.131.4	147	504 MB	08.064.4	29	305 MG	08.226.4	28
7513A EE 02	05.067.4	166	8513A EE AS 02	05.132.4	147	504 MB UL	08.065.4	30	305 MGN UL	08.227.4	28
7513A EE 03	05.068.4	166	8513A EE AS 03	05.133.4	147	2.304 MB UL	08.067.4	30	204 MGR	08.228.4	27
7513A EE 04	05.069.4	166	8513A EE AS 04	05.134.4	147	2.314 MB UL	08.068.4	30	204 MGG	08.229.4	27
731 MCA	05.071.4	155	851 CFP	05.135.4	141	2.304 MB	08.085.4	29	204 MG	08.230.4	27
851 ME 00	05.072.4	144	431 MP	05.136.4	71	2.304 MB CU	08.086.4	31	204 MGN	08.231.4	27
851 ME 01	05.073.4	144	451 MP	05.137.4	71	504 MB CU	08.087.4	31	204 MGR UL	08.232.4	27
851 ME 02	05.074.4	144	431 MR	05.138.4	72	2.314 MB	08.089.4	29	204 MGG UL	08.233.4	27
851 ME 03	05.075.4	144	451 MR	05.139.4	72		08.092.1	209	204 MG	08.234.4	27
851 ME 04	05.076.4	144	431 MRL	05.140.4	73	505 MB	08.094.4	29	204 MGN UL	08.235.4	27
851 MC	05.077.4	140	451 MRL	05.141.4	73	204 MA	08.104.4	17	205 MGR	08.236.4	28
851 CC	05.078.4	140	431 MGR	05.142.4	74	204 MB	08.105.4	17	205 MGG	08.237.4	28
851 CCD	05.079.4	141	431 MGG	05.143.4	74	204 MR	08.111.4	18	205 MG	08.238.4	28
851 EE 00	05.080.4	146	431 MG	05.144.4	74	314 MV	08.116.4	19	205 MGN	08.239.4	28
851 EE 01	05.081.4	146	431 MGN	05.145.4	74	204 MS	08.117.4	18	205 MGR UL	08.240.4	28
851 EE 02	05.082.4	146	451 MGR	05.146.4	74	205 MR UL	08.119.4	25	205 MGG UL	08.241.4	28
851 EE 03	05.083.4	146	451 MGG	05.147.4	74		08.121.4	211	205 MG	08.242.4	28

indice alfanumerico ordinato per codice

product reference directory - ordered by code



sigla part number	codice code	pagina page	sigla part number	codice code	pagina page	sigla part number	codice code	pagina page	sigla part number	codice code	pagina page
205 MGN UL	08.243.4	28	VNR 1/4 MF	11.047.4	206	SCR 4-E	16.019.3	436	FIL 6N-30-A	16.116.0	464
314 MGR	08.244.4	27		11.048.4	206	PR 4-00	16.020.0	454	FIL 6N-05-S	16.117.0	464
314 MGG	08.245.4	27		11.049.4	206	FR 2-08-05-S	16.020.3	408	REG 6N-10	16.118.0	466
314 MGV	08.246.4	27		11.050.4	205	STF 2	16.021.0	458	LUB 6N-00	16.119.0	468
314 MGN	08.247.4	27		11.055.4	205	FR 3-08-05-S	16.021.3	410	FR 6N-10-30-S	16.120.0	470
314 MGR UL	08.248.4	27		11.056.4	206	FR 4-08-05-S	16.022.3	412	FR 6N-10-05-S	16.121.0	470
314 MGG UL	08.249.4	27		11.059.4	206	FIL 4-30-A	16.023.3	380	KIT 6N-00	16.122.0	455
314 MGV UL	08.250.4	27		11.066.4	254	MFIL 2-S	16.024.3	384	STF 6N	16.123.0	476
314 MGN UL	08.251.4	27		11.076.4	255	FR+L 6-10-30-S	16.024.4	422	STF 6NA	16.124.0	476
315 MGR	08.252.4	28		11.077.4	255	MFIL 3-S	16.025.3	384	STF 6NB	16.125.0	476
315 MGG	08.253.4	28	RFU 1/8.2	12.000.4	201	FRL 6-10-30-S	16.025.4	430	M40-00	17.001.0	462
315 MGV	08.254.4	28	RFU 1/8.3	12.000.4-1/4	201	MFIL 4-S	16.026.3	384	M50-00	17.002.0	462
315 MGN	08.255.4	28	RFU 1/4	12.001.4	201	AKS 4-6	16.029.0	456	M63-00	17.003.0	462
315 MGR UL	08.256.4	28	RFU 3/8	12.002.4	201	SCR 3-P	16.029.4	434		17.004.0	214
315 MGG UL	08.257.4	28	RFU 1/2	12.003.4	201	STF 3B	16.030.0	459		17.005.0	214
315 MGV UL	08.258.4	28	RFUM 1/8	12.004.4	202	AVP 3-00	16.030.4	435		17.006.0	216
315 MGN UL	08.259.4	28	RFUM 1/4	12.005.4	202		16.031.0	457		17.007.0	214
	10.001.4	243	RFB 1/8	12.006.4	203		16.032.0	457		17.008.0	214
	10.003.3	226	RFB 1/4	12.007.4	203	REG 2-08-SR	16.032.3	392		17.009.0	217
	10.003.4	245	RFB 3/8	12.008.4	203		16.033.0	457		17.010.0	217
AVP 2-00	10.004.3	432	RFB 1/2	12.009.4	203	SCR 3-E	16.035.3	434		17.011.0	215
	10.009.4	244	RFU 1/8.1	12.010.4	201	FIL 3-30-A	16.036.3	378		17.012.0	215
	10.013.4	256	RFP 1/8.2	12.011.4	202	FIL 6-30-A	16.037.3	382	AZ-CRS1	18.001.0	224
	10.014.4	256	RFU M5	12.047.4	201	FIL 6-05-S	16.038.3	382	AZ-CRS2	18.002.0	224
	10.015.4	257	RFB M5	12.049.4	203	FR 6-10-05-S	16.039.3	414	AZ-CRS3	18.003.0	224
	10.016.4	257	REG 2-08	16.001.3	390	FIL 6-30-S	16.040.3	382	AZ-CRS4	18.004.0	224
	10.017.3	238	FR+L 2-08-25-S	16.001.4	416	PAI 3-00	16.041.0	452		20.100.4	277
	10.018.3	230	KIT 2-00	16.002.2	455	PAI 4-00	16.042.0	453		20.101.4	277
	10.019.3	239	FIL 2-25-S	16.002.3	376	REG 6-10	16.043.3	398		20.102.4	277
	10.021.4	246	FRL 2-08-25-S	16.002.4	424	LUB 6-00	16.044.3	406		20.103.4	277
	10.027.4	237	KIT 3-00	16.003.2	455	FR 6-10-30-S	16.045.3	414		20.104.4	277
	10.029.4	236	LUB 2-00	16.003.3	400	SR-M6	16.046.3	442		20.105.4	277
	10.035.4	229	FR+L 3-08-30-S	16.003.4	418	RPE 3 V NC	16.050.3	444		20.106.4	277
VNR 1/8 FF	11.000.4	205		16.004.2	460	RPE 3 V NA	16.051.3	444		20.107.4	277
VNR 1/4 FF	11.001.4	206	FR 2-08-25-S	16.004.3	408	RPE 3 A NC	16.052.3	444		20.108.4	277
	11.002.4	205	FRL 3-08-30-S	16.004.4	426	RPE 4 V NC	16.053.3	447		20.109.4	277
	11.003.4	206		16.005.2	461	RPE 4 V NA	16.054.3	447		20.110.4	277
	11.004.4	205	REG 3-08	16.005.3	394	RPE 4 A NC	16.055.3	447		20.111.4	277
	11.005.4	206		16.006.2	461	CFIL 2-S	16.056.3	386		20.112.4	277
VNR 1/8 MF	11.006.4	205	FIL 3-30-S	16.006.3	378	CFIL 3-S	16.057.3	386		20.113.4	277
	11.007.4	205	AKS 3	16.007.2	456	CFIL 4-S	16.059.3	386		20.114.4	277
VNR 1/8 MFR	11.008.4	206	LUB 3-00	16.007.3	402	FR+L 6N-10-30-S	16.060.4	472		20.115.4	277
	11.009.4	205	FR+L 4-08-30-S	16.007.4	420		16.061.0	457		20.116.4	277
VNR M5 FF	11.010.4	205		16.008.2	457	FRL 6N-10-30-S	16.061.4	474		20.117.4	277
	11.011.4	205	FR 3-08-30-S	16.008.3	410		16.062.0	457	KSM032	21.001.3	297
RSW 1/8	11.012.4	219	FRL 4-08-30-S	16.008.4	428		16.063.0	457	KSM040	21.002.3	297
RSW 1/4	11.013.4	219		16.009.2	457		16.064.0	457	KSM050	21.003.3	297
RSW 1/2	11.014.4	219	REG 4-08	16.009.3	396		16.065.0	457	KSM063	21.004.3	297
RSTC 1/8	11.017.4	219	PAI 2-00	16.010.2	452		16.066.0	457	KSM080	21.005.3	297
RSTC 1/4	11.018.4	219	FIL 4-30-S	16.010.3	380		16.067.0	457	KSM100	21.006.3	297
	11.024.4	205	STF 3	16.011.0	458		16.068.0	457	KSM125	21.007.3	297
	11.027.4	205	LUB 4-00	16.011.3	404		16.069.0	457	KSM160	21.008.3	297
	11.028.4	206	MREG 2-08	16.011.4	388	KIT 6-00	16.075.0	455	KSM200	21.009.3	297
	11.030.4	206	PR 3-00	16.012.0	454	PAI 6-00	16.076.0	453	KSM032P	21.011.3	297
	11.031.4	205	FR 4-08-30-S	16.012.3	412	STF 6	16.077.0	459	KSM040P	21.012.3	297
	11.032.4	206	AVP 4-00	16.012.4	438		16.078.0	457	KSM050P	21.013.3	297
	11.033.4	206	SR-M3	16.013.3	440	STF 3A	16.083.0	458	KSM063P	21.014.3	297
	11.034.4	205	SCR 4-P	16.013.4	436		16.084.0	457	KSM080P	21.015.3	297
	11.035.4	205	SR-M4	16.014.3	441		16.098.0	457	KSM100P	21.016.3	297
	11.036.4	206	REG 2-04	16.015.3	390		16.099.0	457	KSM125P	21.017.3	297
	11.037.4	206	FIL 2-05-S	16.016.3	376	PR 2-00	16.100.0	454	KSM160P	21.018.3	297
RSW 3/8	11.039.4	219	MREG 2-04	16.016.4	388		16.104.0	457	KSM200P	21.019.3	297
	11.040.4	206	FIL 3-05-S	16.017.3	378		16.105.0	457	KSM032V	21.021.3	297
	11.042.4	205	KIT 4-00	16.018.0	455		16.106.0	457	KSM040V	21.022.3	297
	11.044.4	254	FIL 4-05-S	16.018.3	380		16.107.0	457	KSM050V	21.023.3	297
	11.045.4	205	MREG 1-08	16.018.4	388		16.108.0	457	KSM063V	21.024.3	297
	11.046.4	205	STF 4	16.019.0	459	FIL 6N-30-S	16.115.0	464	KSM080V	21.025.3	297

indice alfanumerico ordinato per codice

product reference directory - ordered by code



sigla part number	codice code	pagina page	sigla part number	codice code	pagina page	sigla part number	codice code	pagina page	sigla part number	codice code	pagina page
KSM100V	21.026.3	297	GD032P	22.113.2	342	GP080P	25.117.2	317	CMIS100	26.024.2N	302
KSM125V	21.027.3	297	GD040P	22.114.2	342	KR063P	25.117.3	326	CMIS125	26.025.2N	302
KSM160V	21.028.3	297	GD050P	22.115.2	342	GP100P	25.118.2	317	CMIS160	26.026.2N	302
KSM200V	21.029.3	297	GD063P	22.116.2	342	KR080P	25.118.3	326	CMIS200	26.027.2N	302
KSM032PV	21.031.3	297	GD080P	22.117.2	342	KR100P	25.119.3	326	CMKS032	26.028.2N	302
KSM040PV	21.032.3	297	GD100P	22.118.2	342	GP032V	25.123.2	317	CMKS040	26.029.2N	302
KSM050PV	21.033.3	297	GD016V	22.120.2	342	GP040V	25.124.2	317	CMKS050	26.030.2N	302
KSM063PV	21.034.3	297	GD020V	22.121.2	342	KR032V	25.124.3	326	CMKS063	26.031.2N	302
KSM080PV	21.035.3	297	GD025V	22.122.2	342	GP050V	25.125.2	317	CMKS080	26.032.2N	302
KSM100PV	21.036.3	297	GD032V	22.123.2	342	KR040V	25.125.3	326	CMKS100	26.033.2N	302
KSM125PV	21.037.3	297	GD040V	22.124.2	342	GP063V	25.126.2	317	CMKS125	26.034.2N	302
KSM160PV	21.038.3	297	GD050V	22.125.2	342	KR050V	25.126.3	326	CMKS160	26.035.2N	302
KSM200PV	21.039.3	297	GD063V	22.126.2	342	GP080V	25.127.2	317	CMKS200	26.036.2N	302
SGM032	21.100.2	296	GD080V	22.127.2	342	KR063V	25.127.3	326	PBIS032	26.037.2N	305
SGM040	21.101.2	296	GD100V	22.128.2	342	GP100V	25.128.2	317	PBIS040	26.038.2N	305
SGM050	21.102.2	296	GD016PV	22.130.2	342	KR080V	25.128.3	326		26.039.0	368
SGM063	21.103.2	296	GD020PV	22.131.2	342	KR100V	25.129.3	326	PBIS050	26.039.2N	305
SGM080	21.104.2	296	GD025PV	22.132.2	342	GP032PV	25.133.2	317		26.040.0	368
SGM100	21.105.2	296	GD032PV	22.133.2	342	GP040PV	25.134.2	317	PBIS063	26.040.2N	305
SGM125	21.106.2	296	GD040PV	22.134.2	342	KR032PV	25.134.3	326		26.041.0	368
SGM160	21.107.2	296	GD050PV	22.135.2	342	GP050PV	25.135.2	317	PBIS080	26.041.2N	305
SGM200	21.108.2	296	GD063PV	22.136.2	342	KR040PV	25.135.3	326		26.042.0	368
SGM032P	21.110.2	296	GD080PV	22.137.2	342	GP063PV	25.136.2	317	PBIS100	26.042.2N	305
SGM040P	21.111.2	296	GD100PV	22.138.2	342	KR050PV	25.136.3	326	PBIS125	26.043.2N	305
SGM050P	21.112.2	296	KP032	25.004.3	326	GP080PV	25.137.2	317	PBIS160	26.044.2N	305
SGM063P	21.113.2	296	KP040	25.005.3	326	KR063PV	25.137.3	326	PBIS200	26.045.2N	305
SGM080P	21.114.2	296	KP050	25.006.3	326	GP100PV	25.138.2	317	COIS032	26.052.2N	309
SGM100P	21.115.2	296	KP063	25.007.3	326	KR080PV	25.138.3	326	COIS040	26.053.2N	309
SGM125P	21.116.2	296	KP080	25.008.3	326	KR100PV	25.139.3	326	COIS050	26.054.2N	309
SGM160P	21.117.2	296	KP100	25.009.3	326	CFIS032	26.001.2N	303	COIS063	26.055.2N	309
SGM200P	21.118.2	296	KP032P	25.014.3	326	CFIS040	26.002.2N	303	COIS080	26.056.2N	309
SGM032V	21.120.2	296	KP040P	25.015.3	326	CFIS050	26.003.2N	303	COIS100	26.057.2N	309
SGM040V	21.121.2	296	KP050P	25.016.3	326	CFIS063	26.004.2N	303	FLIS032	26.070.2N	304
SGM050V	21.122.2	296	KP063P	25.017.3	326	CFIS080	26.005.2N	303	FLIS040	26.071.2N	304
SGM063V	21.123.2	296	KP080P	25.018.3	326	CFIS100	26.006.2N	303	FLIS050	26.072.2N	304
SGM080V	21.124.2	296	KP100P	25.019.3	326	CFIS125	26.007.2N	303	FLIS063	26.073.2N	304
SGM100V	21.125.2	296	KP032V	25.024.3	326	CFIS160	26.008.2N	303	FLIS080	26.074.2N	304
SGM125V	21.126.2	296	KP040V	25.025.3	326	CFIS200	26.009.2N	303	FLIS100	26.075.2N	304
SGM160V	21.127.2	296	KP050V	25.026.3	326	TS8T10	26.010.0	356	FLIS125	26.076.2N	304
SGM200V	21.128.2	296	KP063V	25.027.3	326	CFKS032	26.010.2N	303	FLIS160	26.077.2N	304
SGM032PV	21.130.2	296	KP080V	25.028.3	326	TS12T16	26.011.0	356	FLIS200	26.078.2N	304
SGM040PV	21.131.2	296	KP100V	25.029.3	326	CFKS040	26.011.2N	303	CMSS032	26.079.2N	301
SGM050PV	21.132.2	296	KP032PV	25.034.3	326	TST20	26.012.0	356	CMSS040	26.080.2N	301
SGM063PV	21.133.2	296	KP040PV	25.035.3	326	CFKS050	26.012.2N	303	CMSS050	26.081.2N	301
SGM080PV	21.134.2	296	KP050PV	25.036.3	326	TS25T32	26.013.0	356	CMSS063	26.082.2N	301
SGM100PV	21.135.2	296	KP063PV	25.037.3	326	CFKS063	26.013.2N	303	CMSS080	26.083.2N	301
SGM125PV	21.136.2	296	KP080PV	25.038.3	326	TST40	26.014.0	356	CMSS100	26.084.2N	301
SGM160PV	21.137.2	296	KP100PV	25.039.3	326	CFKS080	26.014.2N	303	CMSS125	26.085.2N	301
SGM200PV	21.138.2	296	GP032	25.103.2	317	TS50T63	26.015.0	356	CMSS160	26.086.2N	301
DSIS032	21.750.0	355	GP040	25.104.2	317	CFKS100	26.015.2N	303	CMSS200	26.087.2N	301
DSIS040	21.751.0	355	KR032	25.104.3	326	TS80T100	26.016.0	356	CIN032	26.088.2N	306
DSIS05063	21.752.0	355	GP050	25.105.2	317	CFKS125	26.016.2N	303	CIN040	26.089.2N	306
DSIS080100	21.753.0	355	KR040	25.105.3	326	TST125	26.017.0	356	CIN050	26.090.2N	306
DSIS125	21.754.0	355	GP063	25.106.2	317	CFKS160	26.017.2N	303	CIN063	26.091.2N	306
DSIS160200	21.755.0	355	KR050	25.106.3	326	TS160T200	26.018.0	356	CIN080	26.092.2N	306
GD016	22.100.2	342	GP080	25.107.2	317	CFKS200	26.018.2N	303	CIN100	26.093.2N	306
GD020	22.101.2	342	KR063	25.107.3	326	SN12D16	26.019.0	357	SNINT032B	26.094.2N	307
GD025	22.102.2	342	GP100	25.108.2	317	CMIS032	26.019.2N	302	SNINT040-050B	26.095.2N	307
GD032	22.103.2	342	KR080	25.108.3	326	SND20	26.020.0	357	SNINT063-080B	26.097.2N	307
GD040	22.104.2	342	KR100	25.109.3	326	CMIS040	26.020.2N	302	SNINT100-125B	26.099.2N	307
GD050	22.105.2	342	GP032P	25.113.2	317	SN25D32	26.021.0	357	CIN125	26.100.2N	306
GD063	22.106.2	342	GP040P	25.114.2	317	CMIS050	26.021.2N	302	PDMC08-10	26.101.2N	273
GD080	22.107.2	342	KR032P	25.114.3	326	SND40	26.022.0	357	PDMC12-16	26.102.2N	273
GD100	22.108.2	342	GP050P	25.115.2	317	CMIS063	26.022.2N	302	PDMC20-25	26.103.2N	273
GD016P	22.110.2	342	KR040P	25.115.3	326	SN50D63	26.023.0	357	FLMC08-10	26.104.2N	274
GD020P	22.111.2	342	GP063P	25.116.2	317	CMIS080	26.023.2N	302	FLMC12-16	26.105.2N	274
GD025P	22.112.2	342	KR050P	25.116.3	326	SN80D100	26.024.0	357	FLMC20-25	26.106.2N	274

indice alfanumerico ordinato per codice

product reference directory - ordered by code



sigla part number	codice code	pagina page	sigla part number	codice code	pagina page	sigla part number	codice code	pagina page	sigla part number	codice code	pagina page
CCMC08-10	26.107.2N	275	CFKN040	26.511.2	330	HS100C050	27.051.0	363	UB012C250	27.121.2	360
CCMC12-16	26.108.2N	275	CFKN050	26.512.2	330	HS100C100	27.052.0	363	UB020C050	27.122.2	360
CCMC20-25	26.109.2N	275	CFKN063	26.513.2	330	HS100C150	27.053.0	363	UB020C100	27.123.2	360
FPT032	26.110.2	286	CFKN080	26.514.2	330	HS100C200	27.054.0	363	UB020C160	27.124.2	360
FPT040	26.111.2	286	CFKN100	26.515.2	330	HS100C250	27.055.0	363	UB020C200	27.125.2	360
FPT050	26.112.2	286	PBUN032	26.537.2	332	HS100C300	27.056.0	363	UB020C250	27.126.2	360
GPT032	26.113.2	285	PBUN040	26.538.2	332	HS100C400	27.057.0	363	UB032C050	27.127.2	361
GPT040	26.114.2	285	PBUN050	26.539.2	332	HS100C500	27.058.0	363	UB032C100	27.128.2	361
GPT050	26.115.2	285	PBUN063	26.540.2	332	HB012C050	27.059.2	362	UB032C150	27.129.2	361
CCR032	26.116.2	285	PBUN080	26.541.2	332	HB012C100	27.060.2	362	UB032C200	27.130.2	361
CCR040	26.117.2	285	PBUN100	26.542.2	332	HB012C160	27.061.2	362	UB032C250	27.131.2	361
CCR050	26.118.2	285	FLUN032	26.570.2	331	HB012C200	27.062.2	362	UB032C300	27.132.2	361
FR8C10	26.119.2	354	FLUN040	26.571.2	331	HB012C250	27.063.2	362	UB032C400	27.133.2	361
FR12C16	26.120.2	354	FLUN050	26.572.2	331	HB020C050	27.064.2	362	UB032C500	27.134.2	361
FRC20	26.121.2	354	FLUN063	26.573.2	331	HB020C100	27.065.2	362	UB040C050	27.135.2	361
FR25C32	26.122.2	354	FLUN080	26.574.2	331	HB020C160	27.066.2	362	UB040C100	27.136.2	361
FRC40	26.123.2	354	FLUN100	26.575.2	331	HB020C200	27.067.2	362	UB040C150	27.137.2	361
FR50C63	26.124.2	354	HS012C050	27.001.0	362	HB020C250	27.068.2	362	UB040C200	27.138.2	361
FR80C100	26.125.2	354	HS012C100	27.002.0	362	HB032C050	27.069.2	363	UB040C250	27.139.2	361
FRC125	26.126.2	354	HS012C160	27.003.0	362	HB032C100	27.070.2	363	UB040C300	27.140.2	361
FR160C200	26.127.2	354	HS012C200	27.004.0	362	HB032C150	27.071.2	363	UB040C400	27.141.2	361
GPM010	26.140.2	272	HS012C250	27.005.0	362	HB032C200	27.072.2	363	UB040C500	27.142.2	361
GPM12-16	26.141.2	272	HS020C050	27.006.0	362	HB032C250	27.073.2	363	UB050C050	27.143.2	361
GPM20-25	26.142.2	272	HS020C100	27.007.0	362	HB032C300	27.074.2	363	UB050C100	27.144.2	361
	26.145.0	369	HS020C160	27.008.0	362	HB032C400	27.075.2	363	UB050C150	27.145.2	361
	26.147.0	368	HS020C200	27.009.0	362	HB032C500	27.076.2	363	UB050C200	27.146.2	361
DCCB 16/32 (M5)	26.156.0T	343	HS020C250	27.010.0	362	HB040C050	27.077.2	363	UB050C250	27.147.2	361
DCCB 32/100 (M6)	26.157.0T	343	HS032C050	27.011.0	363	HB040C100	27.078.2	363	UB050C300	27.148.2	361
	26.164.0	366	HS032C100	27.012.0	363	HB040C150	27.079.2	363	UB050C400	27.149.2	361
	26.165.0	366	HS032C150	27.013.0	363	HB040C200	27.080.2	363	UB050C500	27.150.2	361
	26.166.0	366	HS032C200	27.014.0	363	HB040C250	27.081.2	363	UB063C050	27.151.2	361
	26.167.0	366	HS032C250	27.015.0	363	HB040C300	27.082.2	363	UB063C100	27.152.2	361
SGT032	26.192.2N	284	HS032C300	27.016.0	363	HB040C400	27.083.2	363	UB063C150	27.153.2	361
SGT040	26.193.2N	284	HS032C400	27.017.0	363	HB040C500	27.084.2	363	UB063C200	27.154.2	361
	26.194.0	369	HS032C500	27.018.0	363	HB050C050	27.085.2	363	UB063C250	27.155.2	361
SGT050	26.194.2N	284	HS040C050	27.019.0	363	HB050C100	27.086.2	363	UB063C300	27.156.2	361
	26.195.0	369	HS040C100	27.020.0	363	HB050C150	27.087.2	363	BM012	27.157.0	352
	26.196.0	369	HS040C150	27.021.0	363	HB050C200	27.088.2	363	BM020	27.158.0	352
DSMC8-10	26.196.2	355	HS040C200	27.022.0	363	HB050C250	27.089.2	363	BM025	27.159.0	352
DSMC12-16	26.197.2	355	HS040C250	27.023.0	363	HB050C300	27.090.2	363	BM032	27.160.0	352
DSMC20	26.198.2	355	HS040C300	27.024.0	363	HB050C400	27.091.2	363	BM040	27.161.0	352
	26.219.2	368	HS040C400	27.025.0	363	HB050C500	27.092.2	363	BM050	27.162.0	352
	26.229.0	368	HS040C500	27.026.0	363	HB063C050	27.093.2	363	BM063	27.163.0	352
	26.230.0	368	HS050C050	27.027.0	363	HB063C100	27.094.2	363	BM080	27.164.0	352
	26.231.0	368	HS050C100	27.028.0	363	HB063C150	27.095.2	363	BM100	27.165.0	352
	26.232.0	368	HS050C150	27.029.0	363	HB063C200	27.096.2	363	BM125	27.166.0	352
COIS125	26.320.2N	309	HS050C200	27.030.0	363	HB063C250	27.097.2	363	UB063C400	27.180.2	361
COIS160	26.322.2N	309	HS050C250	27.031.0	363	HB063C300	27.098.2	363	UB063C500	27.181.2	361
CSIS160TI	26.325.2N	308	HS050C300	27.032.0	363	HB063C400	27.099.2	363	UB080C050	27.182.2	361
CSIS200TI	26.326.2N	308	HS050C400	27.033.0	363	HB063C500	27.100.2	363	UB080C100	27.183.2	361
COIS200	26.329.2N	309	HS050C500	27.034.0	363	HB080C200	27.104.2	363	UB080C150	27.184.2	361
SGT032V	26.360.2N	284	HS063C050	27.035.0	363	HB080C250	27.105.2	363	UB080C200	27.185.2	361
SGT040V	26.361.2N	284	HS063C100	27.036.0	363	HB080C300	27.106.2	363	UB080C250	27.186.2	361
SGT050V	26.362.2N	284	HS063C150	27.037.0	363	HB080C400	27.107.2	363	UB080C300	27.187.2	361
SGT032A	26.430.2	284	HS063C200	27.038.0	363	HB080C500	27.108.2	363	UB080C400	27.188.2	361
SGT040A	26.431.2	284	HS063C250	27.039.0	363	HB100C050	27.109.2	363	UB080C500	27.189.2	361
SGT050A	26.432.2	284	HS063C300	27.040.0	363	HB100C100	27.110.2	363	UB100C050	27.190.2	361
SGT032AV	26.433.2	284	HS063C400	27.041.0	363	HB100C150	27.111.2	363	UB100C100	27.191.2	361
SGT040AV	26.434.2	284	HS063C500	27.042.0	363	HB100C200	27.112.2	363	UB100C150	27.192.2	361
SGT050AV	26.435.2	284	HS080C050	27.043.0	363	HB100C250	27.113.2	363	UB100C200	27.193.2	361
CFUN032	26.501.2	330	HS080C100	27.044.0	363	HB100C300	27.114.2	363	UB100C250	27.194.2	361
CFUN040	26.502.2	330	HS080C150	27.045.0	363	HB100C400	27.115.2	363	UB100C300	27.195.2	361
CFUN050	26.503.2	330	HS080C200	27.046.0	363	HB100C500	27.116.2	363	UB100C400	27.196.2	361
CFUN063	26.504.2	330	HS080C250	27.047.0	363	UB012C050	27.117.2	360	UB100C500	27.197.2	361
CFUN080	26.505.2	330	HS080C300	27.048.0	363	UB012C100	27.118.2	360	UB025C050	27.198.2	360
CFUN100	26.506.2	330	HS080C400	27.049.0	363	UB012C160	27.119.2	360	UB025C100	27.199.2	360
CFKN032	26.510.2	330	HS080C500	27.050.0	363	UB012C200	27.120.2	360	UB025C160	27.200.2	360

INDEX

indice alfanumerico ordinato per codice

product reference directory - ordered by code



sigla part number	codice code	pagina page	sigla part number	codice code	pagina page	sigla part number	codice code	pagina page	sigla part number	codice code	pagina page
UB025C200	27.201.2	360		AU.069.1	101	M21A1...		266	N22M4...		288
UB025C250	27.202.2	360		AU.070.1	101	M21A2...		266	N23B2...		288
HS025C050	27.203.0	362	AZ-SE5	AU.071.0	222	M21A3...		266	N23B4...		288
HS025C100	27.204.0	362	AZ-SE4	AU.072.0	222	M21A4...		266	N23M2...		288
HS025C160	27.205.0	362	AZ-SC5	AU.073.0	223	M21A5...		266	N23M4...		288
HS025C200	27.206.0	362	AZ-SC4	AU.074.0	223	M21A6...		266	P11M1...		313
HS025C250	27.207.0	362	AZ-SEP5	AU.075.0	223	M21B1...		266	P11M2...		313
HB025C050	27.208.2	362	AZ-SEP4	AU.076.0	223	M21B2...		266	P11M3...		313
HB025C100	27.209.2	362		AX.007.4	247	M21B3...		266	P11M4...		313
HB025C160	27.210.2	362	P 22804 A	P 22804 A	64	M21B4...		266	P12M1...		313
HB025C200	27.211.2	362	P 22804 B	P 22804 B	64	M21B5...		266	P12M2...		313
HB025C250	27.212.2	362	P 22804 G	P 22804 G	64	M21B6...		266	P12M3...		313
HB080C050	27.230.2	363	P 22804 V	P 22804 V	64	M21M1...		266	P12M4...		313
HB080C100	27.231.2	363	RM 010	RM 010	64	M21M2...		266	P13M1...		313
HB080C150	27.232.2	363	RM 050 N	RM 050 N	64	M21M3...		266	P13M2...		313
	36.625.0	213	RM 050 R	RM 050 R	64	M21M4...		266	P13M3...		313
	AT.005.4	261	RM 055 N	RM 055 N	64	M21M5...		266	P13M4...		313
	AU.000.1	221	RM 055 R	RM 055 R	64	M21M6...		266	P21M1...		313
	AU.001.1	221	RM 056 R	RM 056 R	64	M21S1...		266	P21M2...		313
	AU.002.1	220	RM 065 R	RM 065 R	64	M21S2...		266	P21M3...		313
	AU.003.1	220	RM 066 R	RM 066 R	64	M21S3...		266	P21M4...		313
	AU.004.1	220	RM 200 N	RM 200 N	65	M21S4...		266	P22M1...		313
	AU.005.1	220	RM 300 N	RM 300 N	65	M21S5...		266	P22M2...		313
	AU.006.1	220	RM 313 N	RM 313 N	65	M21S6...		266	P22M3...		313
	AU.008.1	221	RM 350 N	RM 350 N	65	M22A1...		266	P22M4...		313
	AU.009.1	221	RM 383 N	RM 383 N	65	M22A2...		266	P23M1...		313
	AU.011.1	220	RM 400 N	RM 400 N	65	M22A3...		266	P23M2...		313
	AU.013.1	220	RM 413 N	RM 413 N	65	M22A4...		266	P23M3...		313
	AU.014.1	220	RM 450 N	RM 450 N	65	M22A5...		266	P23M4...		313
	AU.015.1	220	RM 483 N	RM 483 N	65	M22A6...		266	P31M1...		313
	AU.016.1	220	RS1-A	RS1/A	364	M22B1...		266	P31M2...		313
	AU.017.1	221	RS1-A 5MT	RS1/A 5MT	364	M22B2...		266	P31M3...		313
	AU.018.1	221	RS2-A	RS2/A	364	M22B3...		266	P31M4...		313
	AU.019.1	221	RS3-A	RS3/A	364	M22B4...		266	P32M1...		313
	AU.020.1	221	RS4-A	RS4/A	364	M22B5...		266	P32M2...		313
	AU.021.1	221	RS5-C	RS5/C	364	M22B6...		266	P32M3...		313
	AU.022.1	221	RS6-3F	RS6/3F	365	M22M1...		266	P32M4...		313
	AU.023.1	221	RS7-3F	RS7/3F	365	M22M2...		266	P33M1...		313
	AU.024.1	221	SH1-P	SH1/P	365	M22M3...		266	P33M2...		313
	AU.025.1	221	SH2-P	SH2/P	365	M22M4...		266	P33M3...		313
	AU.027.1	221	D11M1...		334	M22M5...		266	P33M4...		313
AZ-SC1	AU.040.0	223	D11M2...		334	M22M6...		266	P41M1...		313
AZ-SEP1	AU.041.0	223	D11M3...		334	M22S1...		266	P41M2...		313
AZ-SFE1	AU.042.0	222	D11M4...		334	M22S2...		266	P41M3...		313
AZ-SE1	AU.043.0	222	D12M1...		334	M22S3...		266	P41M4...		313
AZ-SC2	AU.044.0	223	D12M2...		334	M22S4...		266	P42M1...		313
AZ-SEP2	AU.045.0	223	D12M3...		334	M22S5...		266	P42M2...		313
AZ-SFE2	AU.046.0	222	D12M4...		334	M22S6...		266	P42M3...		313
AZ-SE2	AU.047.0	222	D13M1...		334	N11B2...		288	P42M4...		313
AZ-SPL2	AU.048.0	222	D13M2...		334	N11B4...		288	P43M1...		313
AZ-SEP3	AU.051.0	223	D13M3...		334	N11M2...		288	P43M2...		313
AZ-SFE3	AU.052.0	222	D13M4...		334	N11M4...		288	P43M3...		313
AZ-SC3	AU.053.0	223	D21M1...		334	N12B2...		288	P43M4...		313
AZ-SE3	AU.054.0	222	D21M2...		334	N12B4...		288	R11M1...		313
AZ-SPL3	AU.055.0	222	D21M3...		334	N12M2...		288	R11M2...		313
AZ-SFE5	AU.057.0	222	D21M4...		334	N12M4...		288	R11M3...		313
AZ-SFE4	AU.058.0	222	D22M1...		334	N13B2...		288	R11M4...		313
AZ-SPL5	AU.059.0	222	D22M2...		334	N13B4...		288	R12M1...		313
AZ-SPL4	AU.060.0	222	D22M3...		334	N13M2...		288	R12M2...		313
	AU.061.1	101	D22M4...		334	N13M4...		288	R12M3...		313
	AU.062.1	101	D23M1...		334	N21B2...		288	R12M4...		313
	AU.063.1	101	D23M2...		334	N21B4...		288	R13M1...		313
	AU.064.1	101	D23M3...		334	N21M2...		288	R13M2...		313
	AU.065.1	101	D23M4...		334	N21M4...		288	R13M3...		313
	AU.066.1	101	J11M2...		345	N22B2...		288	R13M4...		313
	AU.067.1	101	J11M4...		345	N22B4...		288	R21M1...		313
	AU.068.1	101	J11M9...		345	N22M2...		288	R21M2...		313

